





24ColorCard Camera  rayx.com™

75 H



22102034133

Med
K4592



Digitized by the Internet Archive
in 2017 with funding from
Wellcome Library

<https://archive.org/details/b29818710>



THE
MOTOR MECHANISM
OF PLANTS

BY THE SAME AUTHOR

RESPONSE IN THE LIVING AND NON-LIVING

With 117 Illustrations. 8vo, 10s. 6d. net.

PLANT RESPONSE AS A MEANS OF PHYSIOLOGICAL INVESTIGATION

With 278 Illustrations. 8vo, 21s. net.

COMPARATIVE ELECTRO-PHYSIOLOGY

A Physico-Physiological Study. With 406 Illustrations and Classified List of 321 new Experiments. 8vo, 16s. net.

RESEARCHES ON THE IRRITABILITY OF PLANTS

With 190 Illustrations. 8vo, 7s. 6d. net.

THE PHYSIOLOGY OF THE ASCENT OF SAP

With 95 Illustrations. 8vo, 16s. net.

THE PHYSIOLOGY OF PHOTOSYNTHESIS

With 60 Illustrations. 8vo, 16s. net.

LIFE MOVEMENTS IN PLANTS

Transactions of the Bose Research Institute, Calcutta.

Vol. I. Parts I. and II. With 92 Illustrations. 15s. net.

Vol. II. With 128 Illustrations. 20s. net.

Vol. III. and IV. In one volume. With 107 Illustrations. 20s. net.

THE NERVOUS MECHANISM OF PLANTS

With 82 Illustrations. 8vo, 16s. net.

COLLECTED PHYSICAL PAPERS

8vo, 10s. net.

PLANT AUTOGRAPHS AND THEIR REVELATIONS

With 120 Illustrations. 8vo, 7s. 6d. net.

GROWTH AND TROPIC MOVEMENTS IN PLANTS

8vo.

THE LIFE AND WORK OF SIR JAGADIS C. BOSE, M.A., D.Sc., LL.D., F.R.S., C.S.I., C.I.E.

By PATRICK GEDDES, late Professor of Botany, University College, Dundee, St. Andrews University, and Professor of Sociology and Civics, University of Bombay. With Portraits and Illustrations. 8vo, 16s. net.

LONGMANS, GREEN AND CO. LTD.

London, New York, Toronto, Calcutta, Bombay and Madras

21-22

21-22

THE MOTOR MECHANISM OF PLANTS

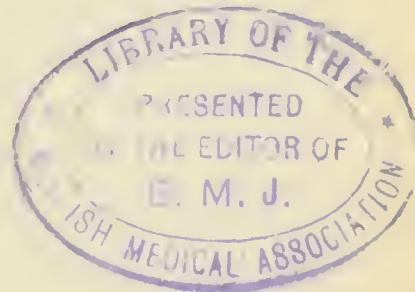

BY

SIR JAGADIS CHUNDER BOSE

M.A., D.SC., LL.D., F.R.S., C.S.I., C.I.E.
CORRESPONDING MEMBER, ACADEMY OF
SCIENCES, VIENNA; MEMBER OF INTER-
NATIONAL COMMITTEE OF INTELLECTUAL
CO-OPERATION, LEAGUE OF NATIONS;
FOUNDER AND DIRECTOR, BOSE RE-
SEARCH INSTITUTE, CALCUTTA

WITH 242 ILLUSTRATIONS



LONGMANS, GREEN AND CO.
LONDON • NEW YORK • TORONTO

1928

2351810

LONGMANS, GREEN AND CO. LTD.

39 PATERNOSTER ROW, LONDON, E.C.4
6 OLD COURT HOUSE STREET, CALCUTTA
53 NICOL ROAD, BOMBAY
167 MOUNT ROAD, MADRAS

LONGMANS, GREEN AND CO.

55 FIFTH AVENUE, NEW YORK
221 EAST 20TH STREET, CHICAGO
TREMONT TEMPLE, BOSTON
210 VICTORIA STREET, TORONTO

WELLCOME INSTITUTE LIBRARY	
Coll.	we!MOmec
Call	
No.	QK

Made in Great Britain



PREFACE

THIS is one more of the series of volumes in which an account of my researches on plant-physiology has, from time to time, been given. The present volume deals more particularly with the investigation of the motor mechanism of the plant as compared and contrasted with that of the animal.

My investigations in this direction date from the discovery announced in a Friday Evening Discourse before the Royal Institution in May 1901, that every plant and each organ of every plant respond to stimulation, the excitation being manifested by an electric response of galvanometric negativity. The method of experimentation and the results are given in detail in my work 'Response in the Living and Non-Living' (1902). Beginning with 'sensitive' plants, I also succeeded in demonstrating that not only these, but ordinary plants as well, respond to stimulation by a mechanical movement, the response being recorded by automatic instruments of high sensitivity ('Plant Response,' 1906). In my 'Comparative Electro-Physiology' (1907) I employed the method of electric response in order to confirm and extend the results which I obtained by the method of mechanical response. Since then a great deal of new material has accumulated, notably within the last two years. The sensitiveness of the methods of experimentation has been carried a great deal further, so that it has been possible to measure, with a fair degree of accuracy, the responsive contraction of even a single cell. The present volume contains a complete and up-to-date account of all my important results on the motor response of

plants, including single and multiple response, as well as automatic movement, dealing at the same time with their functional importance in the life of the plant.

The state of existing knowledge when I commenced my researches in plant-physiology will be best understood from the following extract from a review of my 'Comparative Electro-Physiology' (*Nature*, March 8, 1908) :

There are in Professor Bose's work a great many very interesting observations and ingenious methods of experimentation which will repay the readers' attention. In particular, his experiments on root-pressure and the rise of sap : those by which he seeks to demonstrate that not only sensitive plants but all plants respond to excitation by variation in turgescence and electrical state ; his comparison of the glandular structure of Sundew and Pitcher-plants with animal glands ; in his demonstration on the motile leaflets of *Biophytum* of anodic and kathodic effects of the constant current, and the velocity of excitation of excitatory waves. In fact, the whole book abounds in interesting matter skilfully woven together, and would be recommended as of great value, if it did not continually arouse our incredulity.

This incredulity was but natural since my results contradicted the theoretical views generally held in regard to the reactions of plant-tissues, which were considered to be very different from those of animal tissues. It has even been thought, in certain quarters, that my interpretations of various phenomena observed in the course of my investigations are opposed to recognised principles of plant-physiology. In science, which is always progressive, there cannot be any dogmatic principle constituting an unalterable standard of orthodoxy. It may be claimed that my interpretations are wholly in accord with the principles of physiology in general, the tendency of which is towards the recognition of the essential similarity of the vital processes in animal and plant.

The advance of animal physiology has, in a great measure, been due to the sensitive methods that have been employed in its investigations. In plant-physiology, no such methods had been available on account of the great

difficulty of securing accurate record of responsive reactions which are relatively feeble. The very sensitive instruments that I have been able to perfect have, however, effectively removed all such difficulties, and have made it possible to solve various outstanding problems in plant-physiology by the accurate methods that have been devised.

I have taken the opportunity in this volume to give a more detailed account of the rhythmic peristaltic activity by which the sap is propelled in the plant. Experiments carried out on the animal have also been described, and a general law established in regard to the propagation of the peristaltic and antiperistaltic waves in both animals and plants.

The new results were so revolutionary in their implications and in their effect upon older theories regarding the functioning of plant-life, that there was a controversy in *The Times* in the spring of 1920 as to the reliability of the indications given by my extraordinary high-magnification instruments in recording the automatic pulsations of the plant and its movements in response to external stimulation. An inquiry was, therefore, undertaken by a committee of Fellows of the Royal Society, including Sir William Bragg and the late Sir William Bayliss. The members of the committee reported in *The Times* of May 4, 1920, that they were satisfied that the growth of the plant and its response to stimulation were correctly recorded by my instrument at a magnification of one to ten million times. The successful working of my instruments has on many occasions been exhibited at various scientific centres in Europe, in the United States, and in Japan. In the Physiological Institute of the Vienna University Prof. Molisch, by the employment of my Automatic Cell-Sphygmograph and Optical Sphygmograph, has recently been able fully to confirm my results (*Nature*, August 4, 1928). There can, therefore, be no misgiving about the correctness of fact described in this and in other volumes of the series.

The importance of plant-physiology lies in the prospect

that the study of life in the simpler plant-organisation may lead to the solution of many perplexing problems in the physiology of highly complex animal. This will be in case it can be shown that the fundamental physiological mechanism of the plant is identical with that of the animal. It was my good fortune to foresee and demonstrate this so far back as twenty-two years ago. In the preface to my 'Plant Response' (1906), I wrote :

There is no physiological response given by the most highly organised animal tissue that is not also to be met with in the plant. This was proved in detail in the case of identical polar effects induced in both by electrical currents; in the conduction of the excitatory impulse to a distance; in the possibility of detecting the excitatory wave in transit and measuring its rate; and in the appropriate modification of its velocity by different agencies, even in the case of ordinary plants; in the passing of multiple into autonomous response in vegetable tissues; in the light thrown by this phenomenon on the causes of rhythmicity in animal tissues; in the similar effects of drugs on animal and vegetable tissues. This identity of effects, indeed, as between the responses of plant and animal, is so deep and so extended, that it is to be anticipated that as several of the obscure problems of animal physiology have already found elucidation by means of these researches carried out on plants, so others will be found capable of explanation by similar means in the near future.

This hope has been fulfilled beyond all expectation. It will be seen how the results obtained with plants cast a flood of light on the obscurities of animal response and *vice versa*. Moreover, the highly sensitive methods employed with plants will be, in fact have already been found to be, of great service in researches on animals.

I would like to take this opportunity of acknowledging the most efficient help which I have received from the research assistants and scholars of my Institute in these prolonged investigations.

J. C. BOSE



CONTENTS

CHAPTER I

INTRODUCTORY

	PAGE
Contractility of protoplasm—Motile organ of plants—Automatic movement of growth—Movement in response to stimulation—Conduction of excitation—Automatic pulsation	1

CHAPTER II

THE CONTRACTILE MECHANISM

Mechanical, chemical, thermal, photic, and electric modes of stimulation—Similar reactions under diverse stimuli—Contrivances for accentuation of external stimulus—Quantitative stimulation by electro-thermic method and by induction-shock—High sensitivity of Mimosa—Direct and transmitted excitation—The Response Recorder—Elimination of error arising from friction—The Optical Lever—The method of intermittent contact in record—The Tapping Recorder—The Electro-Magnetic Phytograph—Phytogram its own chronogram—The Resonant Recorder—The Electro-Oscillating Recorder—The Clockwork Oscillator—Characteristic responses of Mimosa, Biophytum, Neptunia, and Erythrina	7
---	---

CHAPTER III

THE MOTOR MECHANISM OF MIMOSA

Feeble contractility of upper half of pulvinus—Quantitative demonstration of unequal pliability of the organ—Movement of fall of leaf due not to flaccidity, but to active contraction—Record of response in normal and in inverted position—Effect of the weight of the leaf—The reaction of the upper half of the pulvinus—Comparison of excitabilities of the two halves in intact plant—Characteristic responses of highly excitable and of subtonic pulvinus—Dependence of amplitude of response on the number of the excited cells—Hastening of recovery under enhanced rate of ascent of sap—The rate of work	28
--	----

CHAPTER IV

CHARACTERISTICS OF MOTOR RESPONSE OF MIMOSA

	PAGE
Determination of the latent period—Additive effect of stimulation—Uniform response—Enfeeblement of response under fatigue—Fatigue—Reversal under continuous stimulation—Dissipation of energy in response—Effect of environmental stimuli in modifying the tonicity of the plant—Tonicity above and below par—Erectile response of subtonic specimens indicative of increase of potential energy of plant—A and D reactions—Transformation from positive to negative response after successive stimulations—Staircase response—Cyclic variation under stimulation—Theory of assimilation and dissimilation	44

CHAPTER V

THE ' ACTIVE SUBSTANCE ' IN QUICKLY CONTRACTILE TISSUES

Active, semi-active, and inactive pulvinus—Anatomy of the pulvinus of Mimosa—Detection of ' active substance ' in the contractile tissue of Mimosa—Localisation of contractile cells by staining—Stained cells sparsely distributed in semi-active pulvinus—Absence of staining in inactive pulvinus—Staining of different pulvini of the same plant—The scale of excitability of pulvini parallel to distribution of stained cells—Granular character of active plasma in rapidly contractile cells—Active and relatively inactive animal muscle—Micro-chemical tests of active substance in the pulvinus	58
--	----

CHAPTER VI

EFFECTS OF EXTERNAL AGENTS ON RESPONSIVE MOVEMENT OF MIMOSA

Effect of variation of light on excitability of Mimosa—Inhibition of power of contraction by excessive absorption of water—Effect of variation of temperature—Stimulating action of Ozone—Asphyxiation produced by Carbonic Acid Gas—Poisonous effect of Sulphuretted Hydrogen—Effect of Ether in depressing excitability—Action of stronger narcotics	68
--	----

CHAPTER VII

THE PETIOLE-PULVINUS PREPARATION OF *MIMOSA PUDICA*

Experimental advantages of cut specimens—Moto-excitability and conductivity—Transmission of excitation through immobile pulvinus—Effect of age on conductivity and excitability—	
--	--

	PAGE
Comparison of moto-excitability of young and old leaves— Effect of wound in modifying excitability—Quantitative deter- mination of rate of decay of excitability after section—Action of light and darkness on moto-excitability—Action of Barium chloride—Antagonistic action of acid and alkali	78

CHAPTER VIII

THE DIURNAL VARIATION OF MOTO-EXCITABILITY IN MIMOSA

The 'sleep' of plants—Determination of periodic variation of excitability—Automatic recorder for twenty-four hours—Uni- form periodic stimulation—Effect of external variations on excitability—Effect of diurnal variation of light—Effects of moderate and excessive lowering of temperature—Effect of variation of temperature above optimum—Record of diurnal variation of excitability of a spring specimen—Uniform excit- ability between noon and 3 P.M.—Gradual increase of excitability between 8 A.M. and noon—Relation between hour of the day, temperature, and excitability—Variation of turgor—Effect of physiological inertia—Effect of season—Diurnal variation of moto-excitability of summer-specimen—Nyctitropic movement as affecting the record	90
--	----

CHAPTER IX

EXCITATION BY POLAR ACTION OF CONSTANT ELECTRIC CURRENT

The Monopolar Method—Effect of feeble current in excitation— Effect of moderate current—Bipolar Method of excitatory re- action—Laws of Polar Excitation of Feeble and Moderate Currents —Effects of stronger currents—Polar reaction of Type III— Polar reaction of Type IV—Polar reaction of leaflets of various sensitive plants—Supplementary Laws of Polar Excitation of Strong Currents—Complications arising from presence of secondary poles—Occurrence of polar reaction of Type III and Type IV even in complete absence of secondary poles—Polar excitation of ordinary plants	106
--	-----

CHAPTER X

THE RESPONSE OF THE ISOLATED PULVINUS

The isolated pulvinar preparation—The pulvinar response—Restora- tion of normal irritability after recovery from shock of operation— Effect of CO ₂ on pulvinar response—Effect of Chloroform— Stimulating action of dilute solution of camphor on Contractile responses of pulvinus of Mimosa and of muscle of Frog—Stimu- lating action of Caffein and of Musk on pulvinar response— Stimulating action of minute dose of Strychnine on pulvinus of Mimosa and on muscle of Frog	118
--	-----

CHAPTER XI

MEASUREMENT OF THE CONTRACTION OF ACTIVE CELLS

	PAGE
Total number of active cells in pulvinus of <i>Mimosa</i> —Contraction under moderate stimulation confined to lower half of pulvinus—Measurement by Method of Diametric Contraction—The Automatic Cell-Sphygmograph—Cellular contraction under stimulation—Measurement of a contractile cell of the pulvinus, and of the amount of its contraction—Diametric contraction of cortical cells in the stem—Continuity of contractile response in cortical cells of pulvinus and stem	129

CHAPTER XII

MOTOR RESPONSE OF ORDINARY PLANTS

Diametric contraction of ordinary stem under stimulation—Experiments with the Optical Sphygmograph—Comparison of sensitivity of ordinary plants and of human subjects—Latent period of ordinary cortex—Modifying effect of tonic condition on the sign of response—Death-spasm under intense electric stimulation—Response of ordinary leaves to direct and indirect stimulation—Measurement of differential excitability of an anisotropic organ—Differential excitability of pulvinus of <i>Mimosa</i> and of leaf-joint of ordinary plant—Differential excitability of petiole—Contractile response of radial organs—Response of the stem by bending under unilateral stimulation—Induction of physiological anisotropy in radial organs—Neutralisation of anisotropy—The cellular mechanism—Response of leaf of <i>Mimosa</i> to supply or loss of water—Response of ordinary leaf—Cellular contraction and expansion under loss or accession of water—Cellular contraction under stimulation	142
---	-----

CHAPTER XIII

RESPONSE BY ELECTROMOTIVE VARIATION

Electric response of <i>Mimosa pudica</i> —The experimental method—Electric response to transmitted excitation—Persistence of electric response when leaf is restrained from movement—Electric response of ordinary plants—Torsional stimulation—Additive effect of stimulation—Apparatus and plant-chamber—Effect of increasing intensity of stimulation—Uniform responses—Fatigue—Effect of temperature—Effects of anaesthetics and poisons	163
---	-----

CHAPTER XIV

ELECTROMOTIVE RESPONSE UNDER PHOTIC
STIMULATION

The photo-electric cell—Response of the leaf to light—Effect of increasing quantity of light—Unmasking of the A-effect on	
---	--

	PAGE
sudden stoppage of light—Phenomenon of 'overshooting' after neutralisation—Positive electric response of <i>Hydrilla</i> —A- and D-effects	178

CHAPTER XV

RESPONSE BY VARIATION OF ELECTRIC RESISTANCE

Variation of resistance under mechanical stimulation—Uniform responses of diminution of resistance—Effect of chloroform—Response to electric stimulation of moderate intensity—Response of subtonic tissue to feeble stimulation—Multiple response under strong stimulation—Quadrant Method for response to stimulus of light—Uniform responses—Response to light from a single spark—Effect of increasing intensity of light—Effect of anaesthetics—Death-response at fatal temperature—Positive and negative reactions	186
--	-----

CHAPTER XVI

THE DEATH-SPASM IN PLANTS

Thermo-mechanical curve of death—Record after death—Lowering of death-point by fatigue—Post-mortem relaxation—Death-excitation in all plants—Thermo-mechanical record of ordinary pulvinus and pulvinoid—Death-response of anisotropic growing organs—Death-excitation of radial organs—Electric excitation at death	200
--	-----

CHAPTER XVII

THE TRANSMISSION OF DEATH-EXCITATION

Transmitted death-excitation of <i>Mimosa</i> —Transmission of death-excitation in <i>Averrhoa</i> —Death-excitation under action of poison—Transmission of excitation and translocation of poison	212
--	-----

CHAPTER XVIII

RECORD OF DEATH BY APPARENT VARIATION IN WEIGHT

The Recording Balance—Death-record of fruit by variation in weight—Death-record of stem, of petiole, and of root—Record of living tissue balanced by dead—The fundamental physiological reaction	219
--	-----

CHAPTER XIX

AUTOMATIC PULSATION

Pulsating leaflet of <i>Desmodium gyrans</i> —The record of pulsation by Oscillating Recorder—Periods of systolic contraction and	
---	--

	PAGE
diastolic expansion—Previous storage of energy necessary for pulsation—Revival of pulsation by external stimulation—Persistence of revived activity dependent on energy previously absorbed—Multiple response, a link between ordinary response and automatic movement—Multiple response under strong indirect stimulation, electric, thermal, and chemical—Detection of multiple electric response in all tissues—Multiple response under direct stimulation—Response on 'all or none' principle—Effect of increasing intensity of stimulation—The refractory period—Cause of rhythmicity—Semi-automatism	229

CHAPTER XX

RHYTHMIC MECHANISM IN PLANT AND ANIMAL

Advantages of the Resonant Cardiograph for accurate record of time-relations at different phases of pulsation—The experimental method of subjecting sinus to external variations—Neurogenic and myogenic theories of origin of heart-beat—Record of rhythmic activity of isolated pulvinule of <i>Desmodium</i> —Criteria of all rhythmic activities—Effect of variation of internal pressure on pulsating animal and plant organs—Oxygen necessary for maintenance of pulsation—Asphyxiating action of CO_2 arresting pulsation in plant and animal—Modifying action of tonic condition on response to external stimulation—Inhibitory action of stimulus on vigorous pulsation—Stimulating action on feeble pulsation—Parallel effects of variation of temperature on pulsation of <i>Desmodium</i> and of the heart—Effect of chemical agents on cardiac and <i>Desmodium</i> pulsation—Physiological antagonism of drugs	248
---	-----

CHAPTER XXI

THE PERISTALTIC WAVE

Functional activity in the propulsion of nutrient substance—Slow propagation of excitation by visible cell-to-cell contraction in rhythmic tissue—Evolution of rapidity of conduction in nervous tissue—Peristaltic wave in alimentary canal—The Peristaltograph—Characteristics of peristaltic pulsation—Effect of deprivation of oxygen arresting peristalsis—Asphyxiation by CO_2 —Effect of variation of temperature on frequency of pulsation of the stomach—Effects of strong and feeble electric stimulation in revival of activity—Effect of chemical stimulation—Peristalsis and antiperistalsis—Peristaltic wave in the heart—Direction of propagation determined by differential activity at two ends of the organ—Reversal of normal wave—Peristaltic wave in the stomach—Effect of stimulation on stomach at standstill—Peristaltic transmission relatively more effective than antiperistaltic—Effect of continuous stimulation—Law of propagation of peristaltic wave	274
---	-----

CHAPTER XXII

THE PROPULSION OF THE SAP

	PAGE
Effect of poison in arresting ascent—Simultaneous reaction of poison on suction and on responsive fall of leaf—Method of Erectile Response—Effect of stimulation in reviving the propulsive activity in subtonic shoot—Effect of variation of temperature on rate of ascent—Effect of alternate application of chemical depressant and stimulant—Irreversible action of poison	293

CHAPTER XXIII

THE HIGH MAGNIFICATION SPHYGMOGRAPH

Uniform sphygmograms—Effect of change of temperature—Effect of variation of the transpiration-current—Simultaneous sphygmogram and phytogram—Transport of sap in normal and in reversed directions—Intensity of transmitted impulse in the two directions—Periodic variation of sap-pressure—Diurnal variation of sap in leafy trees—Diurnal variation in leafless trees	308
--	-----

CHAPTER XXIV

ELECTRIC RECORD OF CELLULAR PULSATION IN
THE PROPULSION OF SAP

Electric pulsation of pulvinule of <i>Desmodium</i> —Automatic mechanical pulsation of pulvinule of <i>Desmodium</i> attended by corresponding automatic electric pulsation—Persistence of electric pulsation even after physical restraint of mechanical pulsation—Localisation of the pulsating propulsive layer by the Electric Probe—Record of the electric pulsation in the active cortex—Effect of diminished and increased internal pressure on mechanical pulsation of <i>Desmodium</i> leaflet, on the electric pulsation of the propulsive layer, and on the rate of ascent of sap—Effect of variation of temperature—Effect of subtonic condition—Peristaltic wave in unidirectioned propulsion of sap	325
---	-----

CHAPTER XXV

THE INDEPENDENT MOVEMENT OF SAP

The Potograph for recording rate of suction—Root not essential for ascent of sap—Transport of sap in absence of root and leaf—Rôle of transpiration in the unidirectioned propulsion of sap—Active ascent in absence of root-pressure and of transpiration—Movement of sap in downward direction—Effectiveness of transport in normal direction greater than in reverse direction—Unequal transport in two directions across cell-wall which acts as a valve preventing in a measure the backward flow	337
--	-----

CHAPTER XXVI

THE RESPONSIVE MOVEMENT OF SAP UNDER
DIFFERENTIAL STIMULATION

	PAGE
Effect of irrigation of the two ends of a bare stem—The residual flow—Effect of thermal stimulation of upper end in inducing movement of sap—Effect of depression of upper end by cold—Effects of stimulation and depression of lower end—Combined effects—Comparison of rate of ascent in intact plant and in a bare stem—The Bubble-method—Effect of enhanced activity of basal end and of depressed activity of apical end—Law of directive flow of sap	348

CHAPTER XXVII

MECHANICAL RECORD OF CELLULAR PULSATION

The Optical Sphygmograph—Effect of pressure at contact on record of sap-pressure—Optical demonstration—Mechanical record of propulsive pulsation—Method of the Magnetic Sphygmograph—Characteristics of pulsation during fall and rise of pressure—Effect of application of heat at cut end of shoot—Effect of ligature on pulsation—Effect of direct stimulation on pulse arrested by ligature—Effect of indirect stimulation	359
--	-----

CHAPTER XXVIII

ACTION OF DRUGS ON PROPULSIVE PULSATION

Identical action of alkaloids and other drugs on propulsion of sap and on circulation of blood—Effect of dilute Camphor on heart-beat of Frog—Effect of Camphor in enhancing sap-pressure by increasing pumping activity—Effect of depressants on heart-beat of animal and on pumping activity in plant—Antagonistic reactions of Musk and KBr on heart-beat—Antagonistic reactions of Musk and KBr on sap-pressure—Action of Atropine and Morphine on animal heart—Parallel action on propulsive activity in plant—Opposite action of minute and large dose of Strychnine on pulsation of animal and plant—Action of Cobra-venom	372
---	-----

CHAPTER XXIX

THE RESPONSIVE MOVEMENT OF SAP IN SEALED STEMS

Increase of sap-pressure in the stem at sphygmographic contact on application of heat above it—Decrease of sap-pressure on application of cold—Erectile response of leaf by application of heat above—Responsive fall of leaf on application of cold—Experiments with bare and sealed stems—Detection of sap-

	PAGE
movement by Sphygmograph—Sap-movement and variation of pressure induced in sealed stem by stimulation—Effect of electric stimulation below contact—Effect of electric stimulation above contact—Effect of simultaneous stimulation below and above—Peristaltic and antiperistaltic waves in stomach and in stem—Effect of chemical stimulant and depressant—Effect of alternate application of stimulant and depressant—Movement of sap transporting chemical substances in leafless trees in spring—Effect of thermal stimulation applied below and above contact—Physiological character of response to stimulation by movement of sap—Effect of thermal depression—Interaction between distant organs—The hydraulic and nervous means of communication—The plant an organised unity	381

CHAPTER XXX

GENERAL REVIEW	403
INDEX	419



ILLUSTRATIONS

FIG.		PAGE
1.	Leaves of <i>Mimosa pudica</i>	7
2.	Electro-thermic stimulator for uniform stimulation	11
3.	Arrangement for applying induction-shock	12
4.	Diagrammatic representation of a Response Recorder	14
5.	The Optical Lever	15
6.	The Tapping Recorder	17
7.	The Electro-Magnetic Phytograph	18
8.	Diagrammatic representation of Resonant Recorder	20
9.	Upper part of Resonant Recorder	21
10.	Complete apparatus for automatic record of response of Mimosa	22
11.	Diagrammatic representation of the Electro-Oscillating Recorder	23
12.	Response-curve of leaf of Mimosa	24
13.	Record of response of leaflet of Biophytum	25
14.	Response of leaf of Neptunia	25
15.	Slow and feeble response of Erythrina	26
16.	Effect of local stimulation of upper half of pulvinus of Mimosa by light	29
17.	Method of measurement of up or down angular displacement under equal weights	30
18.	Curves showing angular displacement under increasing weights which pulled the leaf upwards and downwards	32
19.	Response of Mimosa in normal position and inverted position	33
20.	Effect of weight on rapidity of fall of leaf	34
21.	Effect of amputation of upper half of pulvinus	36
22.	Curves showing differential excitability of upper and lower half of pulvinus of Mimosa	38
23.	Responses of a subtonic specimen of Mimosa	39
24.	Effect of the application of KCl solution on the pulvinus	40
25.	Record of latent period of Mimosa with a 200-vibration recorder	45
26.	Additive effect of stimulus of intensity 0.5	46
27.	Additive effect of stimulus of intensity 0.1	46
28.	Uniform responses of Mimosa	47
29.	Fatigue under shortened period of rest	47
30.	Different phases in the fatigue-reversal in Mimosa	48
31.	Positive, diphasic, and negative response in a subtonic specimen of Mimosa	51
32.	Staircase increase in successive responses of subtonic Mimosa	52
33.	Staircase response followed by fatigue in Mimosa	53

FIG.		PAGE
34.	Preliminary staircase followed by fatigue in the response of Frog's muscle	53
35.	Longitudinal section of petiole and pulvinus of Mimosa	60
36.	Reproduction of photo-micrographs of portions of the pulvini of active Mimosa, semi-active Neptunia, and inactive Bean-plant	64
37.	Transverse sections of pectoral muscles of the falcon, the goose, and the domestic fowl	65
38.	Depressing effect of a passing cloud on the response of Mimosa	69
39.	Abolition of moto-excitability of pulvinus of Mimosa by excessive absorption of water	70
40.	Effect of moderate absorption of water	71
41.	Responses taken on a fast-moving plate, at three different temperatures, 22°, 27°, and 32° C.	72
42.	Stimulating action of Ozone (Mimosa).	73
43.	Effect of carbonic acid gas (Mimosa)	74
44.	Total abolition of excitability and death of plant (Mimosa).	75
45.	Effect of ether (Mimosa)	75
46.	Abolition of excitability under chloroform (Mimosa)	76
47.	The petiole-pulvinus preparation attached to the Resonant Recorder	79
48.	The effect of wound on moto-excitability	84
49.	The effect of wound on detached shoot	85
50.	Stimulating action of light, and depressing action of darkness	86
51.	Incomplete recovery under the action of BaCl ₂	87
52.	Antagonistic action of acid and alkali	88
53.	Diagrammatic representation of the complete apparatus for determination of the diurnal variation of excitability	92
54.	Effect of moderate cooling in depressing excitability	94
55.	Effect of exposure to intense cold	95
56.	Effect of temperature above optimum	96
57.	Record for 24 hours, exhibiting diurnal variation of excitability	97
58.	Midday record from noon to 3 P.M., exhibiting uniform and maximum excitability	98
59.	The gradual waking up of the plant from 8 A.M. to 12 noon	99
60.	Curve of variation of moto-excitability of <i>Mimosa pudica</i>	101
61.	Diurnal variation of moto-excitability exhibited by summer-specimen (Mimosa)	103
62.	Record of diurnal variation of excitability of specimen which exhibited marked nyctitropic movement (Mimosa)	104
63.	Commutator, for causing make and break of electric current	107
64.	Reponse under 8 volts excitation at Km; under 12 volts excitation at Km and at Ab	108
65.	Excitation of leaflets of Biophytum	109
66.	Effect of increasing intensity of current	111
67.	Polar excitation, Type IV	112
68.	Recorder for isolated pulvinus of Mimosa	119
69.	Uniform response of isolated pulvinus (Mimosa)	120
70.	Effect of CO ₂ on response of pulvinus	122
71.	Effect of Chloroform on pulvinar response (Mimosa)	123

LIST OF ILLUSTRATIONS

XXI

FIG.		PAGE
72.	Stimulating action of Camphor on pulvinar response (<i>Mimosa</i>)	124
73.	Stimulating action of Camphor on response of Frog's muscle	124
74.	Stimulating action of Caffein on pulvinar response . . .	125
75.	Stimulating action of Musk on pulvinar response . . .	126
76.	Enhancement of amplitude of response by strychnine . . .	126
77.	Effect of minute dose of Strychnine in enhancing the contractility of Frog's muscle	127
78.	Diagrammatic representation of the measurement of diametric contraction	131
79.	Diagrammatic representation of recorder of diametric contraction	132
80.	The Automatic Cell-Sphygmograph	133
81.	Record of diametric contraction of pulvinus of <i>Mimosa</i> . .	137
82.	Record of diametric contraction of cortex of stem of <i>Mimosa</i> .	140
83.	Effect of increasing intensity of stimulation	143
84.	Response of ordinary leaf under transmitted excitation of thermal shock	146
85.	Diagrammatic representation of method of local electric excitation of the pulvinus of <i>Mimosa</i>	148
86.	Longitudinal contraction of radial growing organ under electric shock (<i>Crinum</i>)	151
87.	Diagram showing connexions for studying the unilateral action of polar current	152
88.	Response of the stem of <i>Phaseolus</i> to unilateral stimulation.	153
89.	Diagrammatic representation of responsive movements of geotropically curved organs to electric stimulation . .	154
90.	Response of geotropically curved organ under diffuse electric stimulation	155
91.	Response of the <i>Mimosa</i> pulvinus to irrigation and to withdrawal of water	157
92.	Response of leaf-joint of <i>Impatiens</i>	158
93.	Response of stem, leaf-joint, and sensitive pulvinus of <i>Mimosa</i> to drought, irrigation, and plasmolysis	159
94.	Responses of stem, leaf-joint, and pulvinus of <i>Mimosa</i> to drought, irrigation, and stimulation	160
95.	Method of obtaining electric response of the pulvinus of <i>Mimosa</i>	165
96.	Uniform response of galvanometric negativity	166
97.	Positive electric response in <i>Mimosa</i>	166
98.	The Torsional Stimulator	170
99.	The Plant-Chamber	171
100.	Response Recorder	172
101.	Increasing amplitude of electric response to increasing torsional stimulation	173
102.	Uniform electric responses under torsional stimulation . . .	174
103.	Fatigue of electric response with shortened period of rest .	175
104.	Abolition of electric response by steam	175
105.	Gradual abolition of electric response under chloroform . .	176
106.	Arrangement for obtaining electric response of the leaf to light	179
107.	Effect of increasing duration of exposure of 5, 10, and 15 seconds	182
108.	The negative electric response of <i>Musa</i> to light	183

FIG.		PAGE
109.	The 'overshooting' of the response of <i>Musa</i>	183
110.	The positive electric response of <i>Hydrilla</i>	185
111.	Experimental method for obtaining response to mechanical stimulation by resistivity variation	187
112.	Record showing uniform responses to mechanical stimulation	188
113.	Effect of Chloroform in inducing depression of response by variation of resistance	189
114.	Method of resistance-variation in response to stimulation . .	190
115.	Effect of electric stimulation of moderate intensity	192
116.	Effect of feeble electric stimulation	192
117.	The Quadrant Method for determination of variation of electric resistance under photic stimulation	194
118.	Equal responses in opposite directions on alternate illumination of the two pairs of quadrants (<i>Tropaeolum</i>)	195
119.	Response to a single spark	196
120.	Effect of stimulus of light increasing in the ratio 1 : 3 : 5 : 7 (<i>Tropaeolum</i>)	196
121.	Death-curve of <i>Mimosa</i>	202
122.	Abolition of response to warming or cooling in specimen which had passed the death-point	203
123.	Lowering of death-point under fatigue	204
124.	Thermo-mechanical curve indicating death-point at 60° C. of leaf of <i>Bean</i> (<i>Phaseolus</i>)	206
125.	Determination of death-point of pulvinoid (<i>Eichhornia</i>) . . .	207
126.	Death-spasm of the geotropically curved stem of <i>Basella alba</i>	208
127.	Determination of the death-point by electromotive variation	209
128.	Multiple response to transmitted death-excitation at 60° C. (<i>Averrhoa</i>)	214
129.	Multiple response of leaflet of <i>Biophytum</i> under transmitted death-excitation due to poisoning	217
130.	The Balance for recording apparent variation in weight at death	220
131.	Record of variation in weight of <i>Carissa</i> fruit at death under rise of temperature	222
132.	Death-record of fruit of <i>Solanum</i>	223
133.	Death-record of stem of <i>Basella</i>	224
134.	Death-record of petiole of <i>Arum indicum</i>	224
135.	Record of living tissue balanced by dead	226
136.	Leaf of <i>Desmodium gyrans</i>	230
137.	U-tube support for the leaf, and the plant-chamber	230
138.	Photograph of the Oscillating Recorder	231
139.	Continuous record of pulsation of <i>Desmodium</i> leaflet for 4 hours	232
140.	Record of a single pulsation of <i>Desmodium</i>	233
141.	Gradual stoppage of pulsation in isolated leaflet of <i>Desmodium</i>	234
142.	Response of <i>Desmodium</i> leaflet in a state of standstill . . .	236
143.	Prolonged revival of pulsation under moderate electric stimulation	236
144.	Effect of photic stimulation in renewing pulsation	237
145.	Multiple response in <i>Biophytum</i> to a moderately strong electric shock	238
146.	Multiple response induced by chemical stimulation	239

FIG.		PAGE
147.	Multiple electric response of Biophytum	239
148.	Multiple response in Biophytum	240
149.	Response of Biophytum leaf to stimulations of varying duration	242
150.	Single response of Desmodium leaflet	242
151.	Stimulus applied at systolic and diastolic phase (Frog)	243
152.	Extra pulsation of Desmodium under stimulation at diastole	243
153.	The Resonant Cardiograph	249
154.	Irregular record of heart-beat of Frog due to friction	250
155.	Characteristic cardiograms of Tortoise, Frog, and Fish	251
156.	Diagrammatic representation of Recorder for the pulvinule of Desmodium	254
157.	Effects of drought and irrigation on pulsation of Desmodium	255
158.	Effects of oxygen and carbonic acid gas in reviving and arresting pulsation of Desmodium leaflet	257
159.	Arrest of normal heart-beat of Frog under the action of CO ₂	258
160.	Revival of Frog's heart-beat by feeble and by strong electric stimulation	259
161.	Effect of strong direct electric stimulation (Desmodium)	260
162.	Effect of strong transmitted excitation	260
163.	The feeble automatic pulsation in dark enhanced after stimulation by light	261
164.	Transmitted effect of moderate and indirect electric stimulation	261
165.	Effect of cooling in arresting the pulsatory activity	263
166.	Effect of rise of temperature in increasing frequency of pulsation (Desmodium)	264
167.	Effect of rise of temperature in enhancement of frequency of heart-beat (Frog)	266
168.	Stimulating action of Spirit. Ammon. Arom. on heart-beat of Frog	267
169.	Stimulating action of Spirit. Ammon. Arom. on Desmodium pulsation	268
170.	Action of a minute dose and of a larger dose of KBr on Desmodium pulsation	268
171.	Opposite effects of minute and strong doses of KBr on heart-beat (Frog)	269
172.	Antagonistic action of Muscarin and Atropin	270
173.	Antagonistic action of Pilocarpin and Atropin	270
174.	Revival of depressed activity of Desmodium by Abroma	271
175.	Parallel effects on pulsating activity of Frog's heart	271
176.	The Peristaltograph	277
177.	Record of automatic pulsations of Frog's stomach	279
178.	Uniform automatic pulsations of Frog's stomach	279
179.	Arrested pulsation of stomach due to lack of oxygen	280
180.	Effect of CO ₂ on normal pulsation of Frog's stomach	281
181.	Effect of variation of temperature on pulsation of Frog's stomach	282
182.	Uniform responses of quiescent stomach to stimulation	283
183.	Four recurrent responses under moderate stimulation	284
184.	Eight recurrent responses on stronger stimulation	284

FIG.		PAGE
185.	Stimulating action of Spirit. Ammon. Arom.	285
186.	Responses to mechanical stimulation (Frog's stomach) . . .	288
187.	Responses to electric stimulation	288
188.	Effects of successive distension of A and B ends	290
189.	Effect of continuous chemical stimulation with Cholin Chlorate	290
190.	Effect of unilateral thermal stimulation	291
191.	Effect of poisonous and of stimulating solutions on shoots . .	296
192.	Effect of poisonous solution in diminishing the rate of suction	299
193.	The Applicator for applying different solutions at cut end of the stem	300
194.	Effect of stimulus of light in enhancing the activity of ascent	302
195.	The arrested activity of ascent revived by electric stimulation .	302
196.	Effect of alternate application of cold in depressing and heat in enhancing rate of ascent of sap	303
197.	Alternate arrest and enhancement of ascent of sap by depress- ant and stimulant	304
198.	Toxic effect of KCN solution	305
199.	Diagrammatic representation of Plant-Sphygmograph . . .	310
200.	The High Magnification Sphygmograph	311
201.	Uniform sphygmograms of young stem of <i>Leucosceptrum</i> tree	312
202.	Effect of variation of temperature on propulsive activity . .	313
203.	Diagram of passage of hydraulic wave from cut end of stem to leaf above	315
204.	Simultaneous sphygmogram and phytogram (<i>Impatiens</i>) . . .	317
205.	Sphygmograms of descending and ascending hydraulic waves in a bare varnished stem	319
206.	Diurnal variation of sap-pressure in leafy tree	322
207.	Diurnal variation of pressure in leafless tree	323
208.	Method for record of electric pulsation of pulvinule of <i>Des-</i> <i>modium</i>	326
209.	Simultaneous record of mechanical pulsation and corresponding electric pulsation of pulvinule of <i>Desmodium</i>	327
210.	The Electric Probe for the localisation of the pulsating tissue in the stem	328
211.	Record showing the amplitude of electric pulsation indifferent layers of the stem of <i>Impatiens</i>	329
212.	Electric connexions for record of electric pulsation of the propulsive layer	330
213.	Record of uniform electric pulsation in the Mango tree . . .	331
214.	Record of electric pulsation under alternate drought and irrigation (<i>Impatiens</i>)	332
215.	Effect of stimulus of light enhancing electric pulsation in a subtonic specimen (<i>Impatiens</i>)	334
216.	The Potograph	338
217.	Curves showing rates of suction in varnished stems of <i>Centaurea</i> and <i>Impatiens</i>	341
218.	Curves showing the effect on transport on sap in a stem when water is applied at either end	345
219.	Diagrammatic representation of the Potograph and of the effects induced by stimulation or depression	353

FIG.		PAGE
220.	Directive flow of sap under differential stimulation at basal end and apical end of the petiole	356
221.	Diagram of Optical Sphygmograph	360
222.	The Complete Optical Sphygmograph	361
223.	Effect on pulsation of alternate drought and supply of water	366
224.	Effect of application of warm water in increasing sap-pressure in a shoot	368
225.	Pulsation arrested by application of ligature	369
226.	Effect of feeble indirect stimulation in enhancing the sap-pressure	370
227.	Effect of dilute solution of Camphor on heart-beat of Frog .	373
228.	Effect of Camphor in enhancing the sap-pressure by increasing the pumping activity	374
229.	Depression induced in plant by Morphine	375
230.	Antagonistic action of Musk and Bromide of Potassium on heart-beat of Frog	376
231.	Effect of KBr in depressing and of Musk in enhancing sap-pressure (Impatiens)	377
232.	Effect of Morphine and Atropine on heart-beat of Frog . .	378
233.	Effect of dilute Strychnine in stimulating the heart-beat of Frog	378
234.	Action of Strychnine on the plant	379
235.	Effects of thermal stimulation or depression on movement of sap in sealed stem	382
236.	Diagram of application of electric stimulation	387
237.	Record of transmitted effects of electric stimulation . . .	389
238.	Diagrammatic representation of effects of chemical stimulant and depressant	391
239.	Record of opposite effects on pressure and movement of sap of Camphor and KBr	392
240.	Method of thermal stimulation	394
241.	Diagram of effect of thermal stimulation and depression . .	398
242.	Record of effects of alternate thermal stimulation and depression	400

THE MOTOR MECHANISM OF PLANTS

CHAPTER I

INTRODUCTORY

MOVEMENT is a characteristic property of living organisms. It may be locomotory, as when the whole organism moves ; or a part of the organism may move, whilst as a whole it remains in the same place. It is probable that the original living organisms were locomotory, swimming in the sea, and from these have been evolved the animal series which are typically motile, and the plant series which are as typically sessile.

The original unicellular living organisms consisted, as do many at present, of nothing but a speck of living protoplasm. Motility, that is the capacity of effecting changes of form or position which we call movement, is an inherent property of protoplasm. This is the starting-point of any possible consideration of the mechanism of movement. The primitive mechanism has been observed to be this : (*a*) that after stimulation the protoplasm reduces the whole or some part of its bulk ; this has been termed ' contraction,' and protoplasm is, therefore, said to be ' contractile ' ; and (*b*) that after contraction the protoplasm recovers its previous bulk, contraction being followed by expansion. The general expression ' contractility of protoplasm ' includes both contraction and expansion.

It appears from what has just been said that any movement of the protoplasm is the result of a previous stimulation, that is, of a disturbance of its equilibrium by some external agent, which is the 'stimulus,' such as a touch, an electric shock, a sudden variation of temperature or of light. Inasmuch as it responds to the action of a stimulus, the protoplasm is described as being 'irritable,' or 'excitable,' or sometimes 'sensitive.'

In the simple unicellular organism the whole of the protoplasm is equally contractile and irritable. In the course of evolution, as more and more complex organisms were developed, attaining various degrees of physiological differentiation, the contractile and the irritable functions have come to be more or less concentrated in certain parts of the body and in certain specialised tissues: contractility in the motor organs, and in the contractile tissue termed 'muscle' in the animal; irritability in the sensory organs receiving and those conducting excitation, and in the tissue termed 'nerve.' But this segregation of function is not absolute. It is most complete in the case of nerve which responds to stimulation without any contraction or other visible indication of its activity: muscle, on the other hand, is both irritable and contractile. In virtue of this combination of properties, conveniently termed 'moto-excitability,' the excitability of muscle is mechanically manifested by its contractile response to stimulation. The excitability of nerve, apart from muscle, can only be detected by the electric variation which it, in common with all the living tissues of the body, undergoes when stimulated, a method which involves the use of the galvanometer.

The differentiation of the tissues has never reached in the plant series anything like the same degree as in the animal series; this is especially true of the motile or contractile tissue, as well of the associated nervous tissue. Hence it is only in a general sense that it is possible to apply the term 'muscle' and 'nerve' to the contractile and the excitatory tissues of plants. It is not surprising that

these tissues should be so highly developed in the locomotory animal, and should be less developed in the sessile plant. Nevertheless I shall be able to show that in the plant the motile organ has reached a degree of complexity hitherto unsuspected, containing as it does contractile tissue which may well be called 'muscle' and conducting tissue which may well be called 'nerve.'

In all but the simplest plants the body is an aggregate of units of protoplasm known as cells, each enclosed in a non-protoplasmic wall. The bulk of the living tissue of the plant is made up of such cells. The cell-wall consists of what may be summarily described as cellulose, within which is the living protoplasm closely lining the wall at all points. Except in quite young cells the protoplasm does not fill the whole cavity of the cell; it adheres to the wall throughout, forming a thin living membrane. The cavity enclosed within this living membrane is the vacuole, filled with the watery cell-sap holding various substances, such as acids, salts, sugar, colouring matters, etc., in solution. It is by such cells as these that the movements of the various parts of the plant-body are effected.

What are the movements that the plant performs? All plants and all parts of them, at a certain stage of development, perform the slow automatic movement known as 'growth.' This movement can only be effected by young cells and is, therefore, a merely temporary feature in the life of an ordinary tissue-cell. But in certain plants, commonly termed 'sensitive plants,' there are groups of cells, situated in special motile organs, which not only retain their power of movement but possess it in an increased degree after they have attained their adult development, and constitute characteristic contractile tissue. The movements, chiefly of the leaves, that these organs effect are not spontaneous, as is growth, but are induced by a stimulus acting from without. It is on this account that the plants manifesting these movements have been described as 'sensitive.' Their motile organs present various grades of both motility and

sensitiveness: some respond with a prompt and active movement to but a slight stimulus, whereas others respond but sluggishly to even a fairly strong stimulus.

What, now, is the ultimate mechanism of the individual contractile cell? What is its condition preliminary to contraction? The first essential is that it should be in good tonic condition, and this is true of all active living cells. What, exactly, are the factors in the state of 'tonus' is not clear, but they must include the excitability that enables the protoplasm to respond to stimulation; and, further, a store of latent energy necessary for the work, whatever it may be—in this case it is contraction—which the cell has to perform. Its mechanical condition is that it is in a state of internal tension, generally termed 'turgor,' like an inflated football; the vacuole contains as much sap as it can hold. The elastic cell-wall is stretched to its utmost; but, as it is readily permeable, there must be some structure which prevents the escape of liquid under pressure from the cell. The structure in question is the lining layer of protoplasm, which is a semi-permeable membrane allowing the entrance of water but resisting the escape of the cell-sap. The accumulation of water in the vacuole is the effect of the osmotic action of substances dissolved in the cell-sap. When a stimulus acts upon the turgid contractile cell, the result is that the cell as a whole shrinks, cell-sap escapes through the protoplasmic lining, and the cell loses its turgidity. On the cessation of stimulation, recovery of the previous condition of the cell begins with reabsorption of water, and ends in the restoration of turgor.

How are these events to be interpreted? They have been interpreted in various ways which need not be discussed here. It must suffice to say that, as the protoplasm has inherent motility, and is known to be sensitive to the action of stimuli, it is the chief factor in maintaining or producing variation of the turgidity of the cell. In response to a stimulus it 'contracts,' a process which must be associated with a sudden increase of its permeability so as

to permit the escape of liquid from the cell with resulting diminution of turgidity. It must be admitted that our present knowledge of the contraction of protoplasm under stimulation is not complete as to the minutiae of the processes by which it is brought about. In muscle it is supposed that during the act of contraction there is a transfer and redistribution of fluid material.¹

In both plant and animal there is thus a fundamental protoplasmic reaction which finds external expression in a movement. Whether or not this reaction is essentially similar in the two cases can only be decided by comparing the records of their responses under all possible variations of external conditions.

Mention should be made of the special case of automatically pulsating tissue. An ordinary muscle undergoes contraction only in response to the action of an external stimulus; but there are other muscular tissues which contract repeatedly with a rhythmic pulsation. A familiar instance of this is afforded by the rhythmic movements of the leaflets of the Telegraph Plant, *Desmodium gyrans*. It is seen in its highest perfection in the animal heart, the rapid rhythmic peristaltic activity of which maintains the propulsion of the blood, a functional activity which has hitherto been unsuspected in the plant. I will in the present work give a more detailed account of the discovery of a rhythmic propulsive mechanism in the plant analogous to that of the animal heart.

There remains further the consideration of the relation of movement to external conditions; for instance, how an electrical current, or heat or light, or chemical substances, or the various changes in the environment, affect the response given by the excitable and contractile cells.

¹ 'Schafer, working on the highly differentiated wing-muscle of the wasp, concludes that each sarcomere contains a darker substance near the centre, divided into two parts by Hensen's disc. At each end of the sarcomere the contents are clear and hyaline. In the act of contraction the clear material flows, according to Schafer, into tubular pores, in the central dark material.'—Starling, *Elements of Human Physiology*, Eighth Edition, p. 91.

In dealing with the movements of plants I will discuss them in the following order :

The Motor Mechanism of Adult Members such as Leaves of Sensitive and other Plants.

The Electric Reaction of Plant-Tissues to Stimulation.

The Mechanism of Multiple and Rhythmic Movement.

The Motor Mechanism of the Distribution of Water.

In addition to the above there still remains The Motor Mechanism of Growing Organs and of Tropic Movements, which will be treated in detail in another volume.

CHAPTER II

THE CONTRACTILE MECHANISM

THE most striking and familiar plant-movement is that shown by the sensitive plants, of which *Mimosa pudica* is the one that has been most extensively investigated. The study of the general features of the motor mechanism may well begin with a detailed account of the leaf of this plant.

The motile organ consists of a large mass of highly excitable and contractile cortical cells in the cushioned

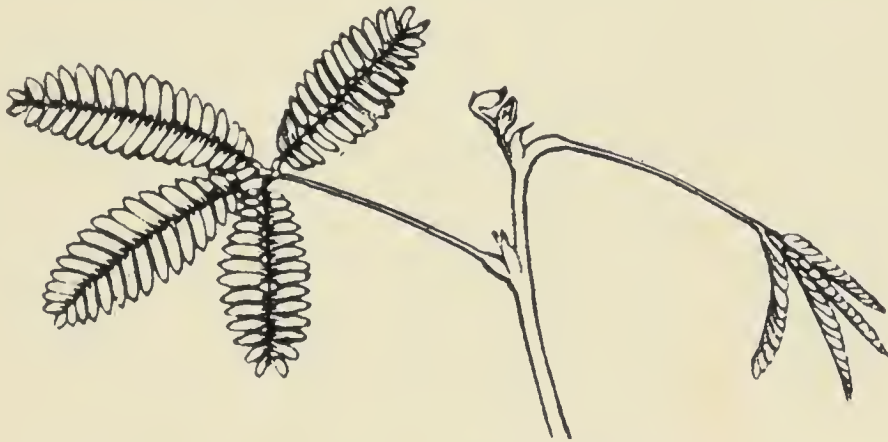

FIG. 1. Leaves of *Mimosa pudica* in expanded condition (left) and contracted condition after stimulation (right).

leaf-joint, the pulvinus. A representation of a pair of *Mimosa* leaves is given in fig. 1; the right leaf has fallen in consequence of a shock. A contraction of the cortical cells of the pulvinus occurs on stimulation. Since the lower half of the pulvinus is, however, much larger, more excitable, and more actively motile than the upper half, on diffuse

stimulation the greater contraction of the lower half causes the leaf to fall. The actual shortening of the lower half of the pulvinus is very small, but as the long petiole acts as a magnifying index, the resulting movement is made conspicuous.

The expulsion of sap from the contracting cells simultaneously with the contractile movement can be successfully demonstrated in a vigorous specimen, as follows :

Experiment 1. *Expulsion of sap from the excited cells.*—A leaf is detached by a cut made at the junction of the pulvinus with the stem. The cut end is immediately placed in a very dilute solution of sodium chloride for several hours so that it may absorb a small quantity of the solution. Although a water-logged condition of the pulvinus, due to excessive absorption of water, causes a diminution or abolition of motility, nevertheless a vigorous pulvinus partially regains its excitability under favourable conditions. The cut end of the pulvinus is then carefully washed with distilled water, and the leaf, held in a clamp, is so arranged that the cut end is just immersed in a dilute solution of silver nitrate. On application of strong thermal shock to the pulvinus there is an expulsion of sap from the cortex, which had previously absorbed traces of sodium chloride. The result is a stream of expelled sap projected into the silver nitrate solution, visually manifested as a string of white precipitate of silver chloride.

It may be asked what happens to the sap expelled from the excited pulvinus in the intact plant. Since the cortex is continuous in the pulvinus and the stem of the plant, the sap expelled from the contracting cells will pass into adjacent unstimulated cells. It will, in fact, be shown in a succeeding chapter that the movement of sap takes place normally along the cortex from cell to cell, from the more stimulated to a less stimulated region. Under strong stimulation the sap may be expelled into the intercellular spaces, and also injected into the xylem, which serves as a reservoir.

Movement being an expression of the contractile reaction, the extent of the movement is a measure of the amount of contraction. If a quantitative stimulus of uniform intensity were applied to the leaf at regular and suitable intervals, and if the physiological condition of the responding tissue remained constant, there would be obtained a series of mechanical responses which would be practically similar to each other. But if the condition were to undergo any change, due to some variation in the environment, then the record would give indications of the invisible internal change. When the vital condition of the plant undergoes depression, the fact is indicated by a diminished amplitude of the mechanical response. If, on the other hand, the moto-excitability of the plant should in any way be enhanced, the amplitude of the response would undergo an increase. The varying effects of freshness and fatigue, of stimulating and depressing drugs, of heat and cold, of light and darkness, are in this way exhibited by characteristic modifications of the response. By means of testing-shocks the plant itself can thus be made to reveal those obscure internal changes which are otherwise entirely beyond our scrutiny.

In the investigation of the response of plants two special difficulties have to be overcome. The first of these is to secure quantitative stimulation of uniform intensity, which may be repeated time after time ; the second is the accurate record of the responsive movement.

METHODS OF STIMULATION.

The plant can be stimulated by employing any agents that excite the animal tissues. The following are the different modes of stimulation :

1. Mechanical : friction, a pinch, a blow, or a prick.
2. Chemical : a drop of acid or other irritant.
3. Thermal : the application of a heated wire.
4. Photic : a beam of sunlight or of light from an arc-lamp.

5. Electric :

- (a) The ' make ' or ' break ' of a constant current.
- (b) The discharge from an electric condenser.
- (c) The electric shock from an induction-coil.

Specific reactions have been assumed for different stimulations. In reality there is no such difference, for results will be described which show that all kinds of direct stimulation of effective intensity give rise to contraction, actual or incipient. It must be borne in mind that there is little vitality in the epidermis or outside skin of the plant-body upon which an external stimulus impinges ; hence arises the necessity for special contrivances by which stimulation at the surface may reach the deeper and more active cortex in an intensified form. There are in the plant various adaptations by which frictional stimulation or the stimulus of light may induce excitation in the living cells. Tactile hairs or bristles accentuate the external stimulus of contact. In *Mimosa*, such hairs occur on the under side of the pulvinus, and by their lever-action cause stimulation of the motor-tissue. In many of the tendrils, again, there are tactile pits by which the stimulus of contact is accentuated. As regards the perception of light, Haberlandt has shown that in many leaves the epidermal cells are lens-shaped, so that the incident light becomes focussed on the sensitive protoplasmic layer, and thus a reaction to the stimulus of light is facilitated. It is obvious that in cases where the epidermis is perfectly opaque there can be no protoplasmic excitation under the action of light. As regards electric stimulation there is no such drawback, since electric shocks can penetrate to the internal tissue.

The ideal form of stimulation for quantitative purposes is one of which the intensity can be kept constant in successive experiments, or be varied in a graduated manner. The two most effective methods for stimulating the plant which fulfil most of the experimental requirements are (1) the electro-thermic stimulus, and (2) the stimulus of an induction-shock.

ELECTRO-THERMIC STIMULATION

Stimulation by direct application of a heated wire causes injury to the tissue. Thermal stimulation, without injury, is rendered practicable by the electric generation of a moderate amount of heat. A loop of fine platinum wire surrounds the petiole which is to be stimulated, the current from a battery being led to the loop by means of a fine flexible silver wire (fig. 2). The electric heating of the platinum loop causes a thermal shock, which may be applied once or several times

in succession by means of a metronome-interrupter. The intensity of the stimulus can be increased or diminished by adjusting the heating current. Care must be taken that the heat produced in the platinum loop is not so great as to injure the tissue. An additional precaution is to put a drop of water between the platinum loop and the enclosed tissue, the excess being removed by blotting-paper. The thin film of water protects the tissue from a burn.

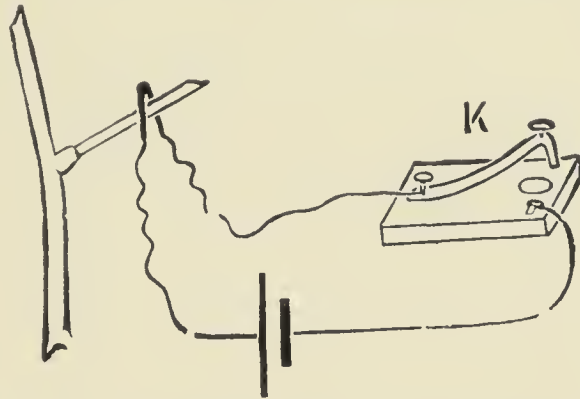

FIG. 2. Electro-thermic stimulator for uniform stimulation; metronome employed in place of key κ , for closing circuit for a definite length of time.

STIMULATION BY INDUCTION-SHOCK

A single shock or a succession of shocks from an induction-coil may be employed. In my earlier experiments this method appeared to be unsuitable for long-continued experimentation, for the plant became insensitive on account of injury caused by successive shocks. Being misled by the prevailing belief that the excitability of the plant was considerably lower than that of the animal, I had been led to employ an intensity of current which was unnecessarily

high. I discovered afterwards that *Mimosa*, in an optimum condition, was ten times more sensitive to an electric shock than a human being. It will further be shown that a shock individually ineffective becomes effective on repetition. The plant may thus be stimulated by subjecting it to a number of feeble shocks, which cause no injury to the tissue. The intensity of the shock can be gradually increased by bringing the primary coil nearer the secondary (fig. 3). Instead of a single make-or-break shock, alternating

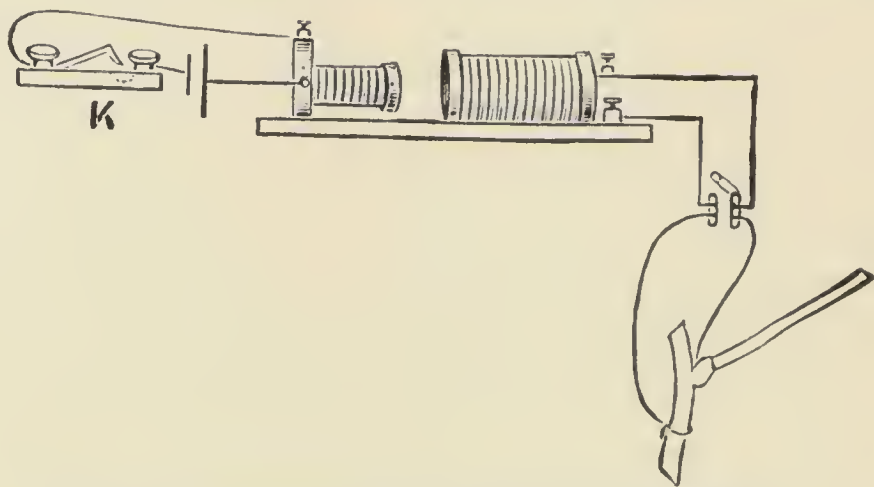

FIG. 3. Arrangement for applying induction-shock.
 K, key in the primary circuit. The secondary circuit may be short-circuited by the second key.

induction-shocks can be produced by an automatic spring-interrupter, included in the primary circuit. The duration of stimulation is adjusted by a metronome which completes the primary circuit for a definite length of time.

The intensity of the exciting shock which I have adopted as the unit, is one which barely induces a perceptible sensation in man. The observer dips two fingers, one of each hand, into two troughs of saline solution, which are in series with the experimental *Mimosa* and the secondary coil. This coil, at first placed at a great distance, is gradually brought nearer the primary till, at a certain scale-reading, the observer just begins to perceive the shock. This scale division is marked as 1. The other positions of the scale are marked in terms of this unit. The calibration is

carried out by means of a ballistic galvanometer. The scale readings indicate intensities of stimulus 0·1, 0·5, 1, 2, 3, 4, and so on. In a highly excitable specimen of *Mimosa* the intensity of shock which causes the fall of the leaf is found to be as low as 0·1 unit.

In a nerve-and-muscle preparation the stimulus may be applied either directly on the muscle or on the distant end of the attached nerve. The excitation transmitted by the conducting nerve reaches the muscle and induces it to contract. Similarly, the pulvinus of *Mimosa* may be stimulated either directly or indirectly; in the latter case the stimulus is applied on the petiole, and the resulting excitation is transmitted along the conducting tissue in the petiole to the pulvinus and causes the fall of the leaf.

I have shown elsewhere that the conducting tissue is the strand of bast or phloem, which functions as a nerve for the rapid conduction of excitation to a distance. It is to be borne in mind that no tissue is a perfect conductor, nor is any a non-conductor of excitation, the difference being a matter of degree. When stimulus is applied at the surface of the plant, the excitation traverses the thin layers of intervening semi-conducting tissue and reaches the phloem, which is an efficient conductor.

THE RECORD OF RESPONSE

The next problem is the accurate record of the movement in response to stimulation. A diagrammatic representation of the recorder used is shown in fig. 4. The leaf is attached by means of a fine thread to one end of the lever, which is pivoted on jewel bearings. The other end of the lever carries a small weight, by which the thread is kept taut. From the middle of the lever and at right angles to it, there extends a thin wire with a curved end serving as the writer. The tip of the wire just touches a smoked-glass plate on which the record is made, the plate being allowed to fall under the action of gravity at a rate regulated by clockwork.

When the leaf executes an abrupt fall on excitation, it pulls down the right end of the lever, so that the writer moves to the left, marking an up-line. The leaf slowly recovers from the effect of the shock and again becomes erect, producing the down-curve of recovery. This record of response, the phytogram, supplies in fact all the information that the myogram affords in the case of the animal

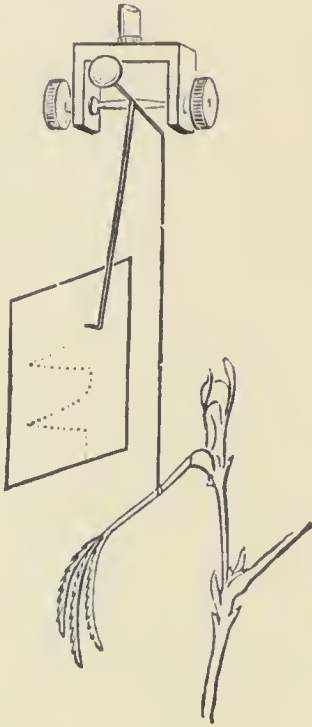

FIG. 4. Diagrammatic representation of a Response Recorder.

muscle. The experimental difficulties in the case of the plant are, however, very great. The pull of the contracting animal muscle is so considerable that the friction offered by the recording surface constitutes no essential obstacle, though even here the time-relations of the curve are rendered unreliable on account of the friction. But in the plant the contractile movement is, generally speaking, only feeble: hence the friction offered, even by the smoked-glass surface, introduces serious error in the record of the amplitude and time-relations of the response.

I have succeeded in eliminating the frictional error by the employment of different devices, each of which possesses a certain advantage for the requirements of a particular investigation. The different devices are :

1. The Optical Lever.
2. The Tapping Recorder.
3. The Electro-Magnetic Phytograph.
4. The Resonant Recorder.
5. The Electro-Oscillating Recorder.
6. The Clockwork Oscillator

THE OPTICAL LEVER

The responsive movement can be magnified even to ten thousand times or more by an optical method. The petiole of *Mimosa*, or the leaflet of any sensitive plant, is attached by a cocoon-thread to the lever. A small reflecting mirror

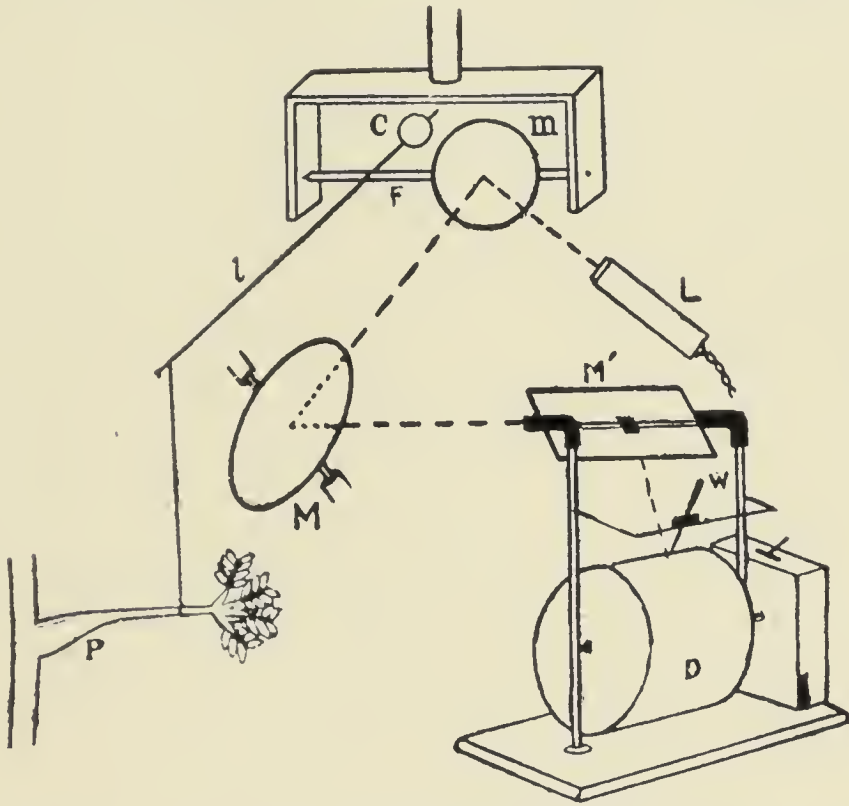

FIG. 5. The Optical Lever.

P, plant; l, lever passing through fulcrum rod F with counterpoise c; m, mirror attached to fulcrum-rod; L, electric lamp; M, mirror for transforming vertical into horizontal movement of spot of light; M', throws down light on revolving drum D, excursion of which is followed by writing-pen w.

is attached to the fulcrum-rod, the rotation of which, under pull of the falling leaf or leaflet, is highly magnified by the light reflected from the mirror, the magnification depending on the distance of the recording surface. The spot of light falls on a vertical revolving drum, round which is wrapped a length of sensitive bromide paper; the curve of response and recovery is thus obtained by subsequent photographic development. The record can also be taken on a horizontal drum, by following the moving spot of light with

a pencil. In this case the vertical up- or down-movement is converted into a right or left movement by a second reflection from another mirror, suitably inclined (fig. 5).

Taking a record by the photographic method necessitates the employment of a dark room : but many plants lose their sensibility in the dark. In order to obviate this difficulty and also the discomfort of working in a dark room, I devised several types of direct mechanical recorders in which the response is inscribed on a moving smoked-glass plate, the error of friction being avoided by making an intermittent, instead of a permanent, contact, the record consisting of a series of dots instead of a continuous line. Intermittent contact can be produced either by making the writing-lever tap dots on the recording plate, or by making the recording plate itself move to-and-fro, so as to come periodically in contact with the writing-lever. The first type is designated the Tapping Recorder and the second the Oscillating Recorder. These instruments can be employed in recording the movements not only of sensitive but also of ordinary plants.

THE TAPPING RECORDER

The principle and construction of this apparatus will be understood from fig. 6. A leaf is attached to the short arm of a light horizontal lever, which records its movements on a smoked-glass plate, kept moving from right to left. This latter movement is produced by the action of a spring barrel which pulls the plate-carrier to the left, the rate of release and resulting movement of the plate being adjusted by clockwork ; a thread attached to the plate-carrier is wound round the wheel of a clock, the size and rate of rotation of which modify the speed of the recording plate. The rate of rotation of the clock-wheel can be continuously adjusted by a special governor, so that the apparatus can be used for records of either short or long duration. The tip of the lever is not in contact with the smoked glass, but about 2 mm. away from it ; it is made to press periodically

against the recording surface by means of the striker S, attached to a sliding device. The striker is at a short distance from the lever and at right angles to it. A momentary pull of

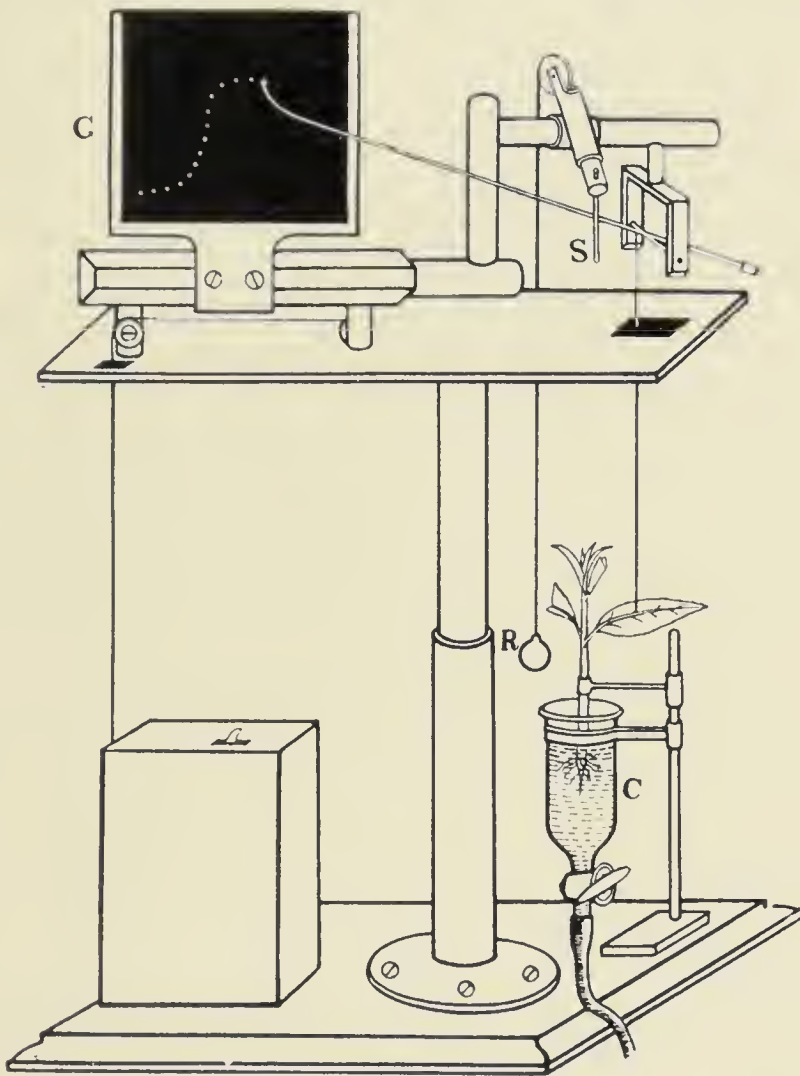

FIG. 6. The Tapping Recorder.

Plant placed with root in water-vessel c. Leaf attached to recording-lever which is periodically pressed against smoked-glass plate C, by means of striker S, actuated by pull on the ring R (*see text*).

the ring R with its attached string makes the slide move and press the striker S against the recording-lever which marks a dot on the smoked-glass plate. The successive dots may thus be made at any interval of, say, 2 to 10 seconds. This method of record is relatively simple in working and requires few adjustments.

THE ELECTRO-MAGNETIC PHYTOGRAPH

It is, however, far more convenient to have the record rendered perfectly automatic. The Phytograph which has

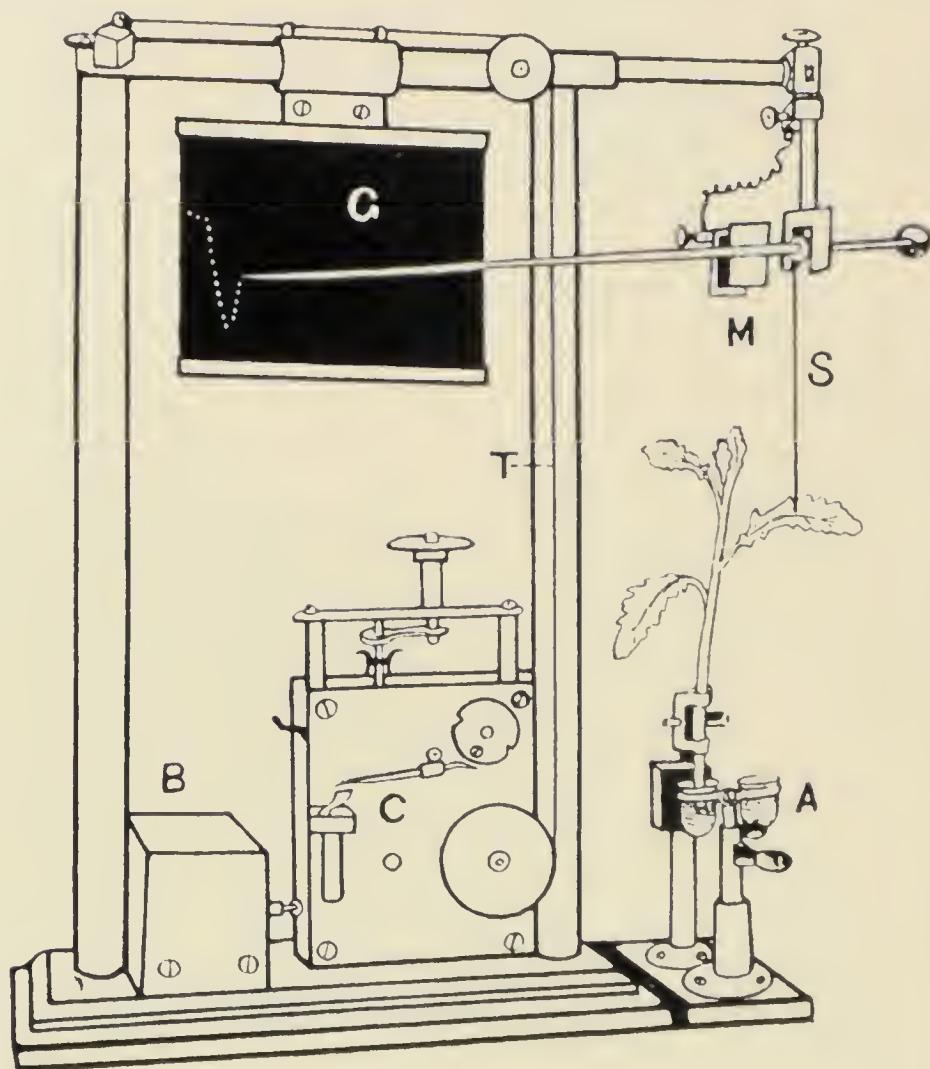

FIG. 7. The Electro-Magnetic Phytograph.

Leaf attached to hinged recording-lever, the steel wire in which is periodically attracted by electro-magnet *M*. Intermittent closure of electric circuit made by contact-maker *C*, actuated by toothed wheel. *B*, box containing dry cell. Thread *T*, attached to plate-carrier, is wound round clock-wheel, rotation of which is regulated by governor. Two cups (one marked *A*) containing water or other liquid can be rapidly applied as required to the cut end of stem (*see text*).

been devised for the purpose is very reliable and sensitive. The leaf is attached by a thin silk thread to the recording-

lever, which magnifies the movement of the leaf from 10 to 200 times. The lever is hinged and a short piece of steel wire is attached to the recording-lever in front of a small electro-magnet M; the steel wire, periodically attracted at equal intervals by an intermittent electric current sent through the electro-magnet, causes the recording-lever to make a series of dot-marks on the smoked plate. The intermission of the current is produced by a contact-maker C, actuated by clockwork (fig. 7). The current required for working the electro-magnet is extremely feeble. One small dry cell out of the three employed in an electric torch has been found to last for more than a fortnight for working the apparatus. The electric cell is enclosed in the box B.

In the different types of recorders described above, the error arising from friction is completely removed by the method of intermittent dots for the record. The successive dots, moreover, measure definite intervals of time; the phytogram is thus its own chronogram. The interval between the dots can be made to vary from 1 to 20 seconds, which is sufficient for measurement of the rate of responsive movements of sluggish plants. But in the highly excitable *Mimosa* the responsive contraction is extremely rapid, and it is therefore necessary to record time-intervals as short as a tenth, a hundredth, or a thousandth of a second. I will now describe the special Resonant Recorder that has been devised for the purpose of recording such rapid movements.

THE RESONANT RECORDER

A diagrammatic representation of this Recorder is given in fig. 8. The writer W is a fine steel wire which has to be maintained in a state of resonant vibration, and is exactly tuned to vibrate, say, ten times in a second; it is supported on jewel bearings at the centre of one pole of a circular electro-magnet. The magnetising coil is in circuit with a storage-cell B, and a vibrating reed V which periodically completes the electric circuit. When the reed is exactly

tuned to vibrate ten times in a second, the recording-writer is thrown into sympathetic vibration and strikes the smoked-glass plate once every tenth of a second. With finer recorders it is possible to measure as short a time as a thousandth

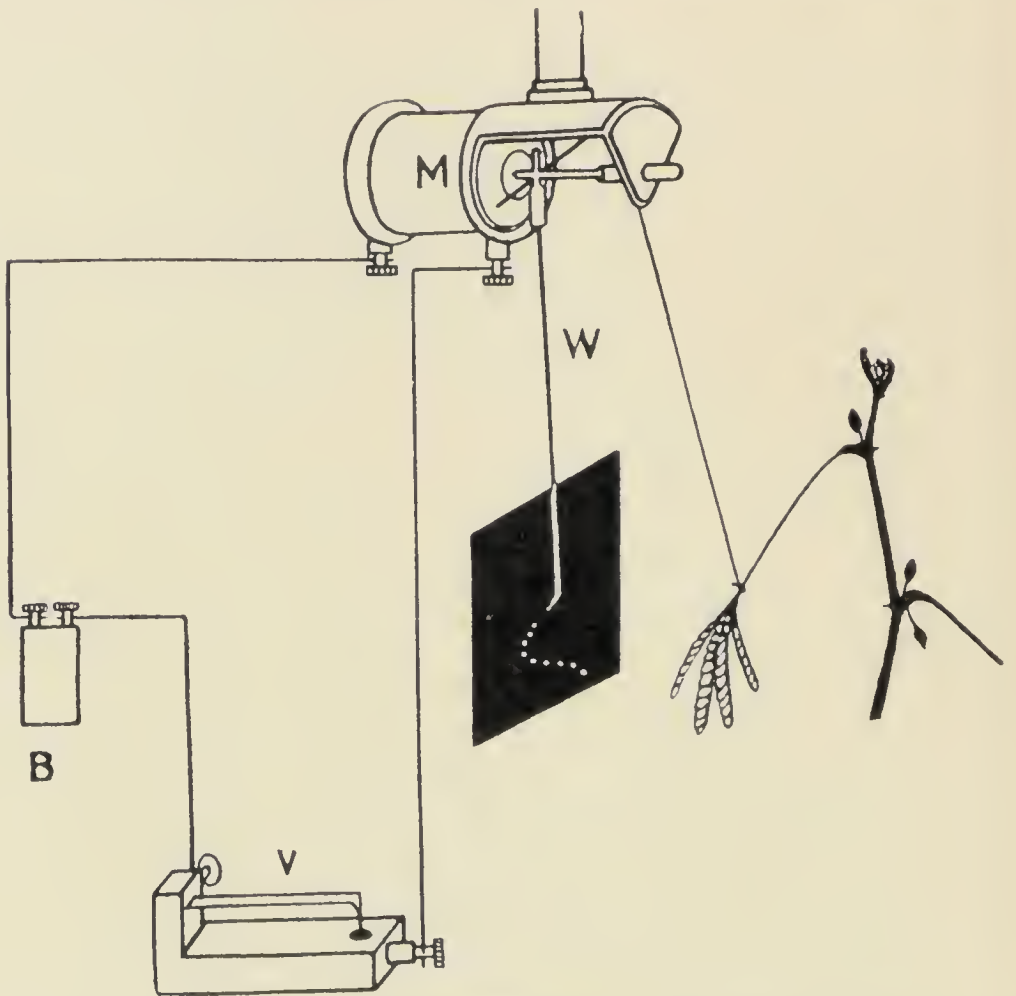

FIG. 8. Diagrammatic representation of Resonant Recorder.
 M, electro-magnet; W, resonant writer; B, battery; V, vibrating reed.

part of a second. A photograph of the upper part of the Resonant Recorder is given in fig. 9.

The records of response of *Mimosa* given in this chapter were taken with the Resonant Recorder. The complete apparatus is illustrated in fig. 10. In order that the results obtained should not be influenced by the personal equation, arrangements were made that the plant attached to the recording apparatus should be automatically excited by an

absolutely constant electric stimulus, and should make its own responsive records, go through its period of recovery, and repeat the same cycle without assistance or interference at any point on the part of the observer.

In the instruments described it is the recording-writer

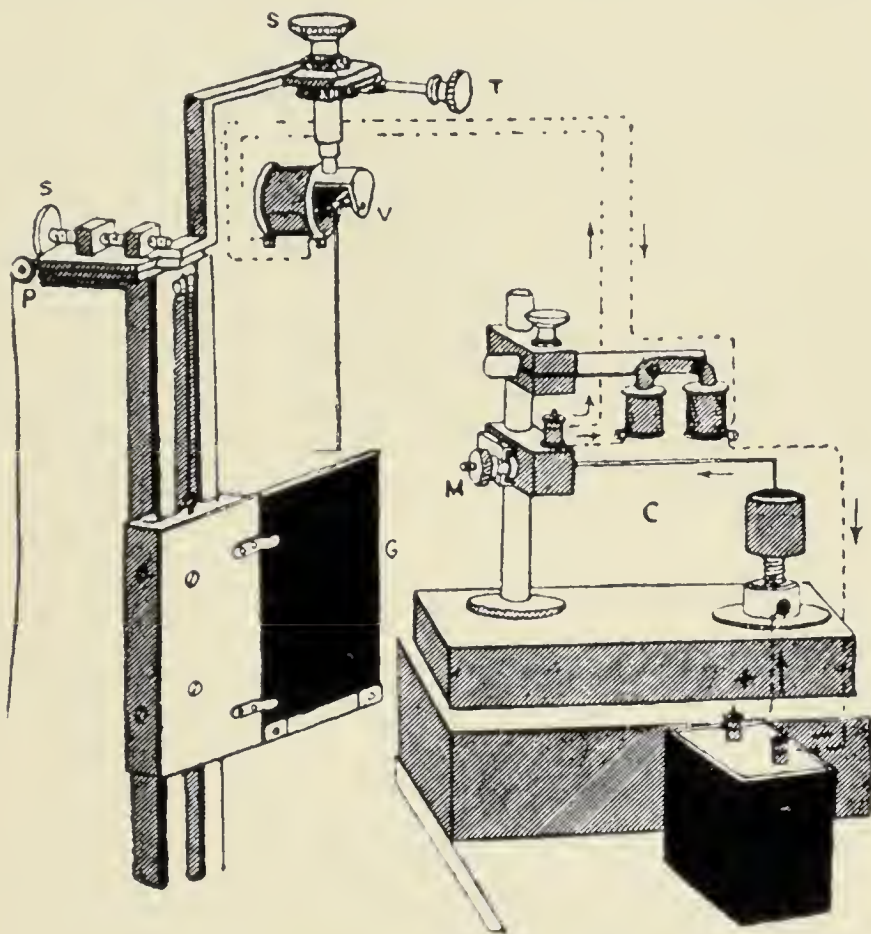

FIG. 9. Upper part of Resonant Recorder.
(From a photograph.)

that vibrates and taps the record. In the Oscillating Recorder the plate is made to move to-and-fro, and thus to come in intermittent contact with the tip of the writer.

THE ELECTRO-OSCILLATING RECORDER

The smoked-glass carrier is mounted on a ball-bearing slide for oscillation to-and-fro at right angles to the tip of the writer. The oscillation of the plate-carrier is secured by

two pairs of small electro-magnets, periodically activated by the passage of an electric current through them. One pair of coils is fixed, and the second pair is movable, being attached to the slide on ball-bearings by which the plate-carrier is

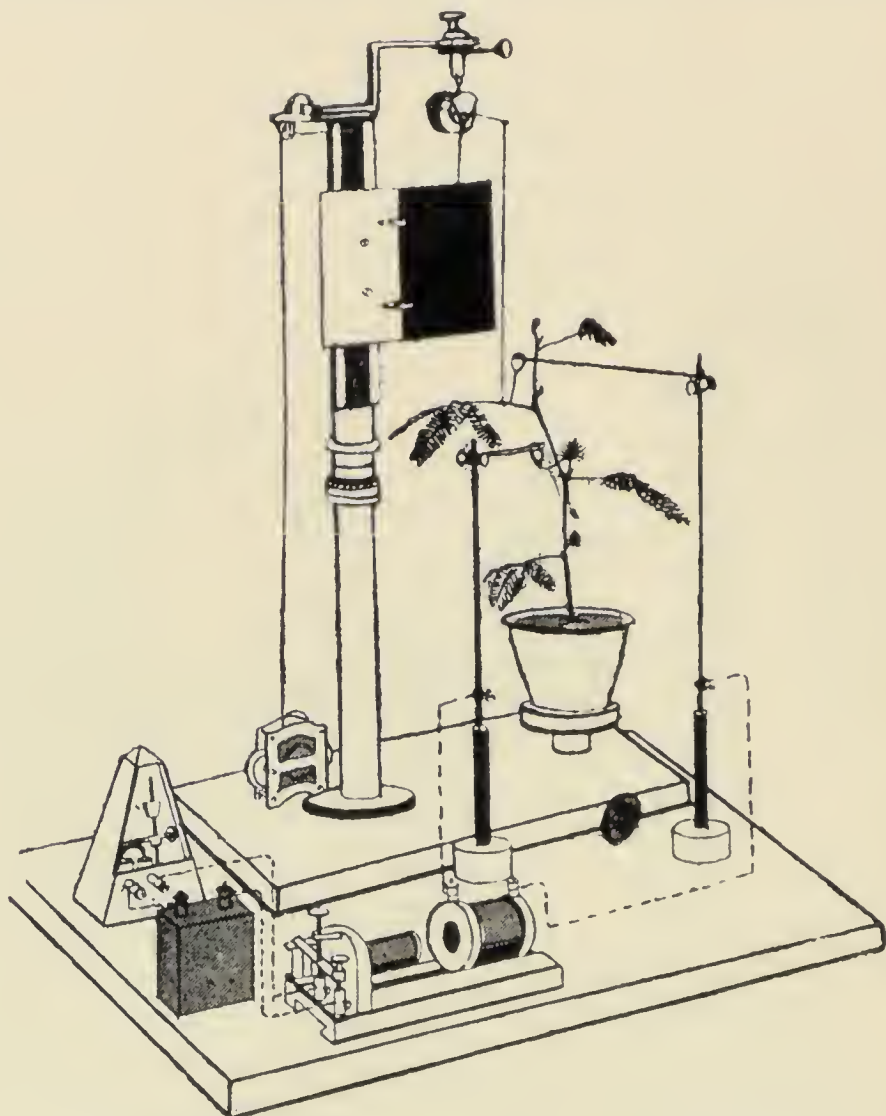

FIG. 10. Complete apparatus for automatic record of response of *Mimosa*.

made to oscillate. The arrangement of the two pairs of coils is such that the N and S poles of the moving coils face respectively the S and N poles of the fixed coils. The two pairs of coils are slightly separated from each other by a light spring. An electric current periodically sent through the two coils by a contact-maker activates the coils, and

the electro-magnetic attraction moves the slide forwards, bringing the smoked-glass plate in brief contact with the tip of the writing-lever which thus makes a dot (fig. 11).

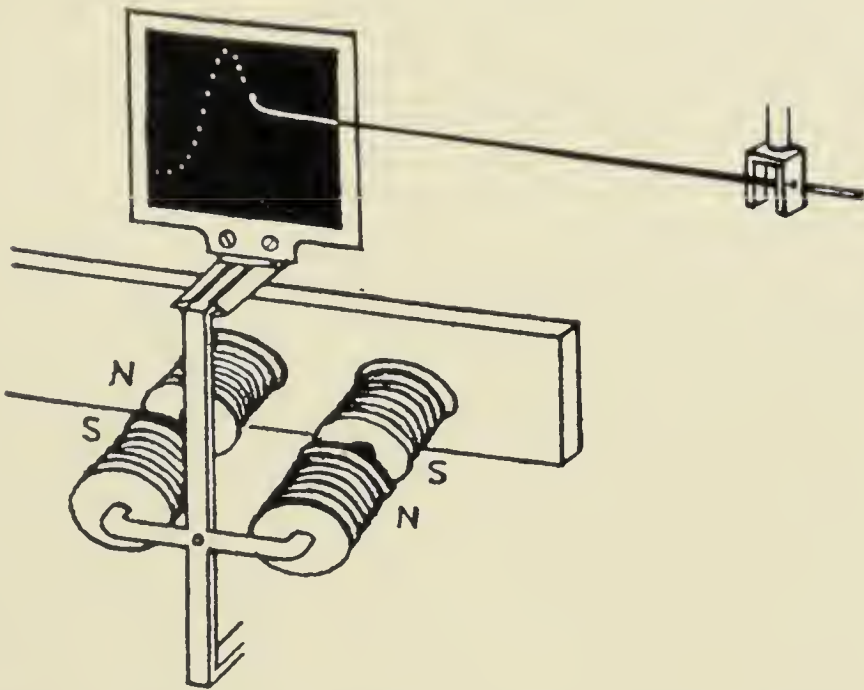

FIG. 11. Diagrammatic representation of the Electro-Oscillating Recorder. Electro-magnetic oscillating arrangement alone shown in the figure.

On the cessation of the electric current the slide recedes, and another dot is produced at the next forward movement of the slide.

THE CLOCKWORK OSCILLATOR

In this an eccentric actuated by clockwork produces a periodic to-and-fro movement of the carrier of the smoked plate. A detailed description of this apparatus will be given later.

Having explained the method of uniform stimulation and the accurate means of record, I will describe the responses of various pulvinated organs which exhibit very interesting and characteristic differences.

RESPONSE OF MIMOSA

Experiment 2.—The record is a horizontal line when the leaf is in the normal outspread position. Electric stimulation of intensity $0\cdot1$ was applied at *a*; the specimen was highly excitable and the stimulation proved to be quite effective. The movement of excitatory fall is represented by the up-curve, and the erectile movement of recovery by the

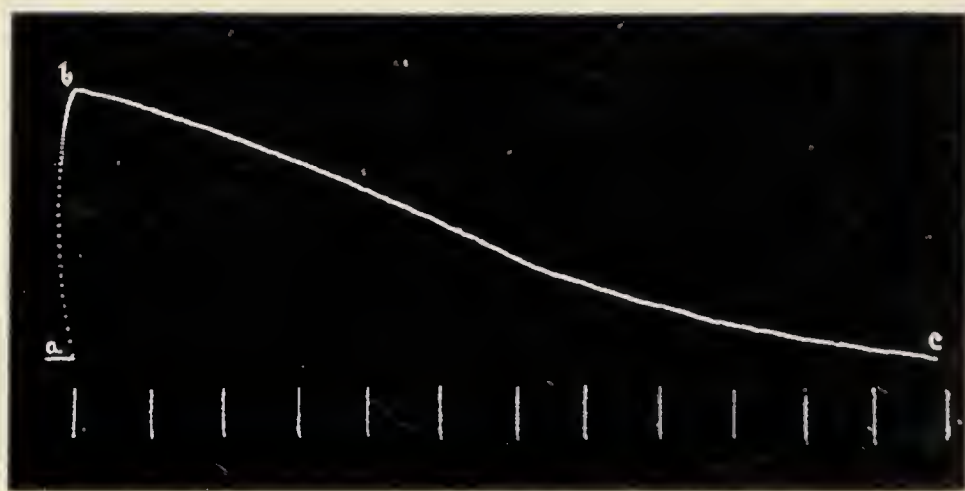

FIG. 12. Response-curve of leaf of Mimosa.

The vertical lines below the record indicate intervals of 1 minute each.
a b, fall of leaf; *b c*, recovery.

down-curve. The contractile reaction was very rapid, and the successive dots in the record are correspondingly separated from each other. The recovery was very slow, hence the superposed dots appear as a continuous line (fig. 12). The period of maximum fall *b* is often as short as $1\cdot1$ second, while in less vigorous specimens it may be as long as 3 seconds; the period of complete recovery *b c* is, however, comparatively long, varying under different circumstances from 8 to 20 minutes. The maximum rate of the contractile fall of the leaf is about 24 mm., while that of the erectile recovery is $0\cdot09$ mm. per second.

RESPONSE OF LEAFLET OF BIOPHYTUM

Experiment 3.—*Biophytum* is also highly excitable, a responsive contraction taking place under comparatively feeble stimulation; the recovery is quicker than in *Mimosa* (fig. 13). The response and recovery were completed in the course of only 3 minutes. Successive and uniform responses can therefore be obtained with this plant at shorter intervals than with *Mimosa*.



FIG. 13. Record of response of leaflet of *Biophytum*.

Vertical marks below record indicate intervals of 0.5 minute.

RESPONSE OF NEPTUNIA

Experiment 4.—In contrast with the high excitability and rapid contraction of *Mimosa* is the comparatively feeble excitability and sluggish response of *Neptunia oleracea*. The



FIG. 14. Response of leaf of *Neptunia*. Successive dots are at intervals of 0.5 minute in the contractile portion, and 1 minute in the recovery portion of curve.

minimum stimulus for excitatory contraction of the leaf is 2 units, and the maximum contraction is attained in 3 minutes in a moderately vigorous and in 1 minute in an exceptionally vigorous specimen (fig. 14).

RESPONSE OF ERYTHRINA

Experiment 5.—There are numerous other pulvinated leaves, such as those of *Phaseolus* and of *Erythrina indica*, which are usually regarded as insensitive to mechanical or electric shocks. This supposition is, however, erroneous, since a responsive movement, under a moderately strong stimulus, can be clearly demonstrated by means of high magnification. The response of *Erythrina* is seen to be



FIG. 15. Slow and feeble response of *Erythrina*. Stimulus applied at vertical line. Successive dots are at intervals of 30 seconds.

very similar to that of *Mimosa*, the difference consisting in the great sluggishness of the reaction, the maximum contractile fall occurring only after 8 minutes (fig. 15).

Though the pulvini of different plants are anatomically very similar, yet there are characteristic differences in the rate of their reaction, some being active, others semi-active, and still others practically inactive. On what does this differing rate of reaction depend? This problem will be discussed in a subsequent chapter.

SUMMARY

The vital activity of the plant at any moment can be gauged by its contractile response to a definite testing stimulus.

The plant-tissue is stimulated by the same agents that excite the animal tissue. For quantitative investigations, devices have been perfected for thermal and electric stimulation of the plant, such that the intensity of the stimulus can be kept constant or increased in a graduated manner.

The pulvinus of *Mimosa* is far more sensitive than had been previously supposed. Quantitative tests show that in an optimum condition it gives a responsive fall to an intensity of electric stimulus, below the threshold of human perception.

Accurate records of responsive movement have been secured by the Optical Lever, which gives a magnification more than a thousand times. Records have also been obtained with different types of mechanical recorders. The error arising from friction is eliminated by the intermittent contact in the records taken with the Tapping and the Oscillating Recorders. The dotted curve gives the time-relations of the response: the phytogram is its own chronogram. With the Resonant Recorder time-intervals as short as 0.001 second can be accurately measured.

Contractility is a general characteristic of living tissues. In pulvinated leaves response by a movement of fall is effected by the greater contraction of the more excitable lower half of the pulvinus. Many pulvini, usually regarded as quite insensitive, also respond, though by a feeble and relatively sluggish movement. In regard to the rapidity of contractile response, *Mimosa* is highly active, *Neptunia* semi-active, and *Erythrina* is relatively inactive.

CHAPTER III

THE MOTOR MECHANISM OF MIMOSA

As has been previously explained, the two halves of the pulvinus may be conveniently distinguished as upper and lower—that is, above and below the vascular cylinder. The lower half is known to be highly sensitive, whilst the upper half of the organ is commonly supposed to be quite insensitive.

The downward movement of the leaf after stimulation has been considered to be brought about passively by the flaccid pulvinus yielding to the weight of the leaf, whilst Haberlandt regards the movement of fall as being accentuated by the expansion of the upper half of the pulvinus. I will, however, show (1) that the upper half of the pulvinus is also sensitive, though feebly, and responds to stimulus by contraction; (2) that the fall of the leaf is due to the active and predominant contraction of the lower half of the pulvinus; (3) that the factor of active contraction is so great that the weight of the leaf has little effect in hastening the fall; and (4) that the fall of the leaf is not helped by any expansion of the upper half of the pulvinus.

I will first demonstrate that the upper half of the pulvinus is excitable.

CONTRACTILITY OF UPPER HALF OF PULVINUS

Experiment 6.—The upper half of the pulvinus was locally stimulated by a narrow beam of light from an arc-lamp acting from above. This gave rise to a relatively feeble up-movement due to contraction of the upper half

of the organ. A magnification of 30 times was necessary to obtain a record of moderate size. The latent period for initiation of response was 20 seconds. Owing to physiological inertia, the response persisted for a certain length of time, after which there was a recovery (fig. 16). Under stronger or long-continued stimulation the excitation becomes transmitted across the pulvinus to the more excitable lower half, causing an energetic down-movement.

The results prove that both the upper and the lower



FIG. 16. Effect of local stimulation of upper half of pulvinus of *Mimosa* by light. Application of light at arrow, its cessation at arrow within circle. Erectile movement shown by down-curve.

halves of the organ are sensitive, and that the resultant fall on diffuse stimulation is due to the predominant contraction of the lower half. It should be mentioned here that the minimum intensity of stimulus necessary for the contraction of the upper is considerably stronger than for that of the lower half (*cf.* Experiment 12, p. 37).

UNEQUAL PLIABILITY OF THE ORGAN

There is an additional purely mechanical factor, the unequal pliability of the organ in the two directions, that enfeebles the up-response. The unequal movement upwards or downwards under the action of the same force is demonstrated by the experimental method illustrated in fig. 17.

The petiole is subjected to an equal pull, upwards and downwards, and the resulting displacement of the long aluminium index is read on the circular scale. A thread is tied to the petiole, the ends of which are attached to two

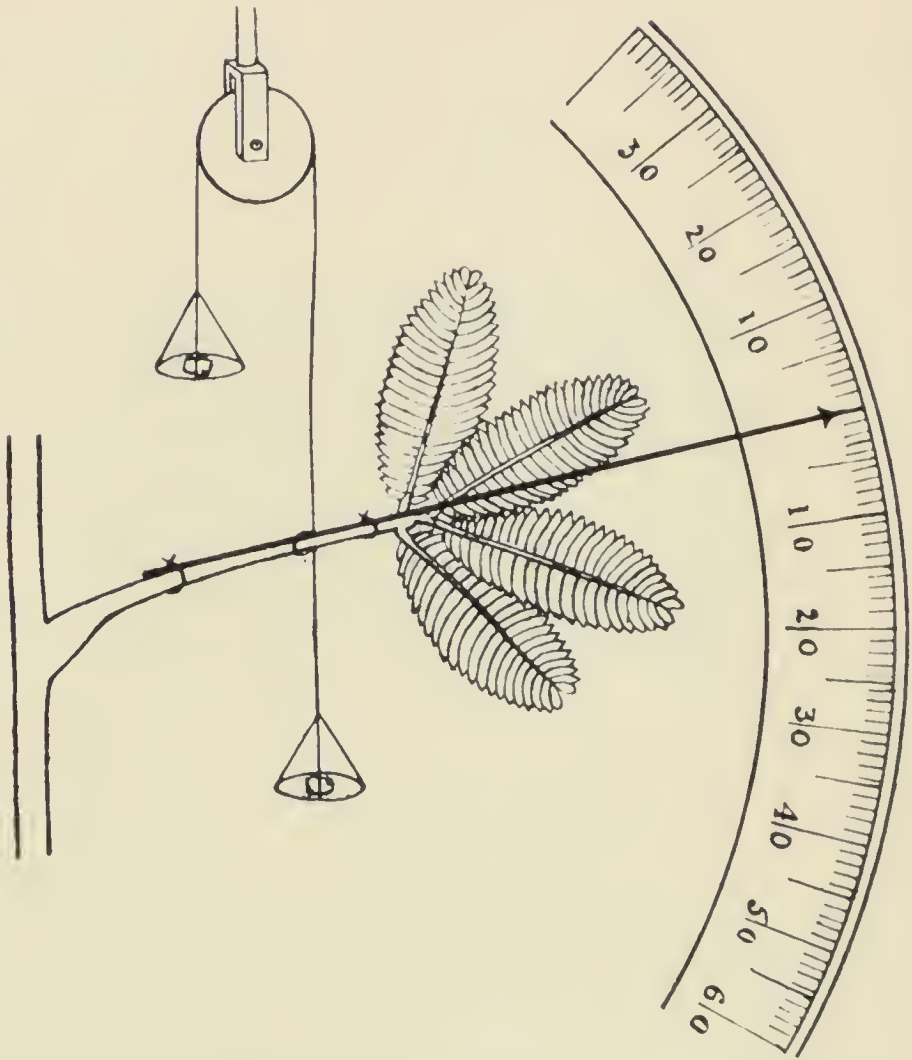

FIG. 17. Method of measurement of up or down angular displacement under equal weights.

small aluminium pans of equal weight : the upper portion passes over a frictionless pulley.

Experiment 7.—In the first series of observations successive weights of 0.25 gm. are carefully added to the upper pan, causing an upward tension. The increasing angular displacement reached a limit of 21° under a weight of 1.5 gm. ; when this was increased to 2 gm. no further

displacement was produced. On the removal of the weight the leaf regained almost its former position. The experiment was repeated by successive additions of 0.25 gm. to the lower pan, causing an increasing downward pull. The angular displacement was now very much greater; under a weight of 2 gm. the downward displacement was 58° , in contrast to the limiting upward displacement of 21° . The following table gives a detailed account of the results:

TABLE I.—SHOWING THE DIFFERENCE BETWEEN UPWARD AND DOWNWARD DISPLACEMENT, UNDER EQUAL WEIGHTS.

Weight in gm.	Angular displacement in degrees upwards	Angular displacement in degrees downwards
0.5	10	12
0.75	15	21
1.0	18	29
1.25	20	38
1.5	21	44
1.75	21	51
2.0	21	58

It should be mentioned here that the downward sinking of the leaf brought about by the careful addition of a weight is in no way connected with the excitatory fall, for the removal of the weight is followed by an immediate recovery of its original position. The curves (fig. 18) show the great difference between the upward and downward displacements. The movement under the same force is thus considerably less in an upward direction. The feebleness of the erectile response to local stimulation may therefore be regarded as the joint effect of the low excitability of the upper half and of the unequal pliability of the organ. A cylinder of lignified sclerenchyma surrounds the vascular bundles in the petiole, the rigidity of which is in a great measure due to this protective cylinder. In the pulvinus itself there is no such lignification of the cylinder; were it lignified, the very marked responsive movement of the pulvinus would be an impossibility. There is another important

factor which also renders the movement unequal in the two directions. Schwendener has shown that the lower side of the pulvinus, in contrast to the upper, is more conspicuously provided with furrows like the folds of the skin in a human finger. I obtained very interesting results

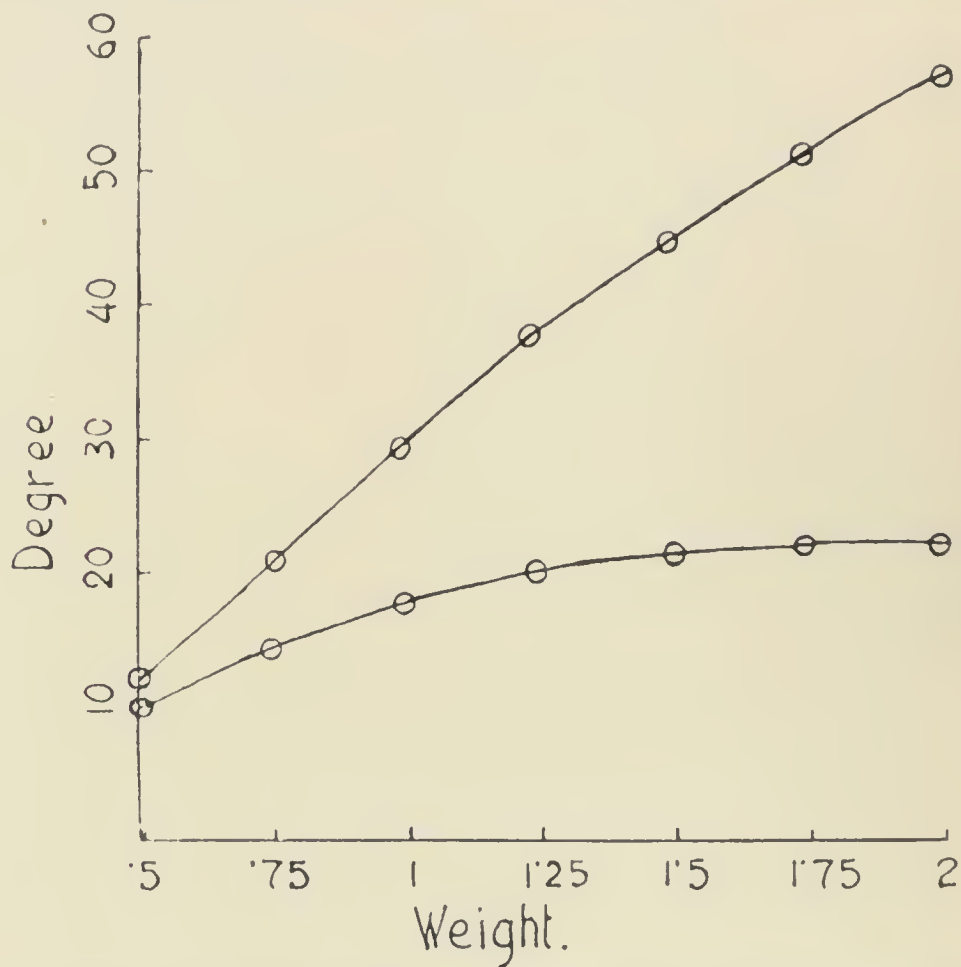

FIG. 18. Curves showing angular displacement under increasing weights which pulled the leaf upwards (lower curve) and downwards (upper curve).

in making longitudinal sections of the pulvinus under two different conditions. In making the sections, the cut made by the razor acts as an intense stimulus, causing contraction and concave curvature of the lower half; the furrows now become very conspicuous. But if the pulvinus be previously benumbed by freezing, its contractility disappears, and the subsequent sections exhibit no furrows. These furrows,

under normal conditions, permit of considerable curvature of the pulvinus in a downward direction without any compression or deformation of the tissue.

THE MOVEMENT OF FALL OF THE LEAF

The fact that the excitatory fall of the leaf is due not to passive yielding of the flaccid pulvinus but to active contraction is clearly demonstrated by the following experiment.

Experiment 8.—Response to an electric shock was first taken of the leaf of a potted Mimosa (fig. 19, *a*). It was then

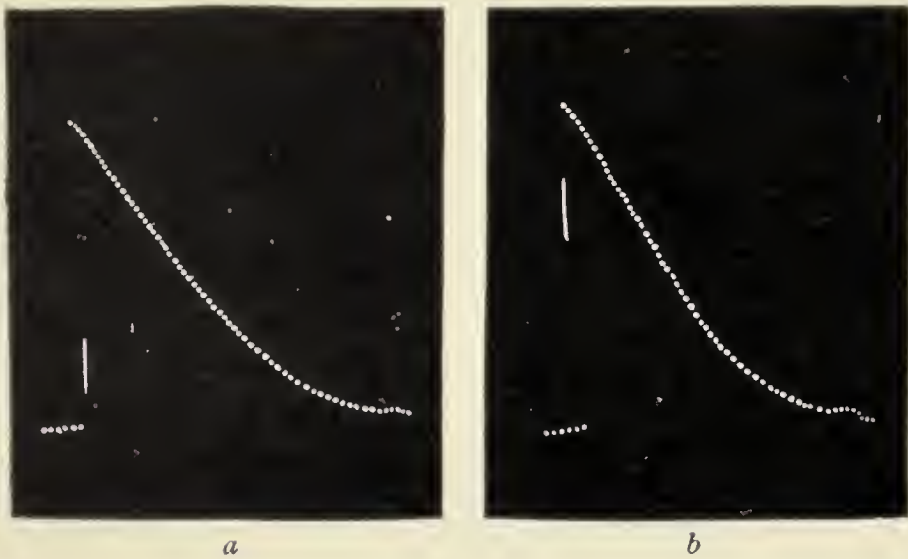

FIG. 19. Response of Mimosa in normal position (*a*) and in inverted position (*b*).

Movement due to contraction of lower half represented in both by an up-curve, which on account of its rapidity is seen as a scratch.

In *a* it is the fall of the leaf that is represented by the up-curve ; in *b* it is the erectile movement.

held in an inverted position and response to similar electric shock obtained once more. The response was now an erectile movement, lifting the weight of the leaf against the force of gravity. The record was taken with the Oscillating Recorder, the successive dots being at intervals of 10 seconds. The maximum contraction, causing maximum erectile movement, occurred in the course of 2 seconds, which is also the average value for the

maximum fall of the leaf in the normal position. Comparison of the two records (a) and (b) (fig. 19) shows the essential similarity of response in the normal and in the inverted positions. This proves that *the normal fall of the leaf under stimulation is due not to flaccidity but to active contraction.*

EFFECT OF THE WEIGHT OF THE LEAF

The factor of active contraction is so great that the rapidity of the responsive movement of the leaf is but little affected by its weight. I describe experiments carried

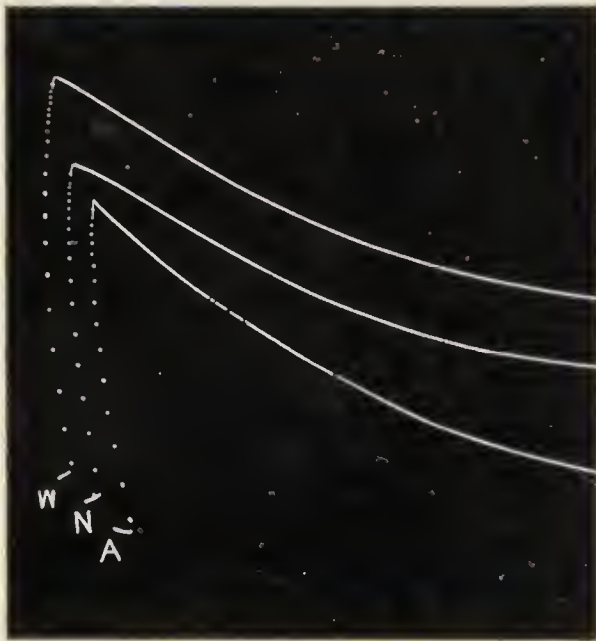

FIG. 20. Effect of weight on rapidity of fall of leaf.

N, curve of response without weight ;
w, with weight helping ; A, weight opposing.

out with one and the same plant which fully justify this conclusion.

Experiment 9.—The records of response were taken under the following conditions: (1) when the leaf was helped during fall by its weight; (2) when the action of weight was practically eliminated; and (3) when the fall had to be executed against an equivalent weight.

The mechanical share of the leaf in the movement of fall may be regarded as mainly due to the weight of the four sub-petioles and their leaflets acting at the end of the main petiole. In the following series of experiments the sub-petioles were cut off and their weight found to be 0.5 gm. The main petiole was now attached to the right arm of the lever, and three successive records were taken: (1) with

no weight attached to the petiole; (2) with 0.5 gm. attached to its end; and (3) with 0.5 gm. attached to the left arm of the lever at an equal distance from the fulcrum. In the first case the fall due to the excitatory contraction will have little weight to help it; in the second case it will be helped by a weight equivalent to that of the sub-petioles; and in the third case the fall will be opposed by an equivalent weight. The records (fig. 20) show that in these three cases there was practically no difference in the time taken by the leaf to complete its fall, the period being about 1.6 second.

THE REACTION OF THE UPPER HALF OF PULVINUS

Having proved that the weight of the leaf has little effect in the rapidity of the fall, I will next consider the contention that the movement of fall is effectively helped by the supposed expansion of the upper half of the pulvinus previously in a state of compression. The influence of this expansive force can be tested by taking two records—one under normal conditions, and the other after the removal of the upper half of the pulvinus.

Experiment 10. *Response before and after removal of the upper half.*—The record of response of an intact leaf was first taken on a fast-moving plate. The upper half of the pulvinus was then removed and a second record obtained, under stimulus of the same intensity as before. Pfeffer was unable to obtain any response after the removal of the upper half; his failure, I find, is due to the loss of irritability caused by the intense shock of operation. I have been able to reduce the shock-effect to a minimum by local application of cold, which temporarily benumbed the tissue. The normal excitability was found to be restored about 3 hours after the operation. Comparison of the two records before and after the operation showed that there was practically no difference in the rapidity of the fall, the time required for maximum fall being in both cases 1.1 second (fig. 21). The

upper half of the pulvinus has, therefore, no effect in hastening the fall of the leaf.

Experiment II. *Effect of removal of lower half of the pulvinus.*—A record was taken of the response after removal of the lower half. The shock-effect caused by the amputation of the lower half was found to be very great, and it required a long period of rest before the upper half regained its excitability. Stimulation by electric shock induced *contraction of the upper half of the organ and caused an erection of the leaf.* This is an additional proof of the fact previously



FIG. 21. Effect of amputation of upper half of pulvinus.

Upper record gives normal response before amputation, and the lower, response after amputation. Successive dots at intervals of 0.1 second. Maximum fall after 1.1 second in both.

demonstrated that the upper half is also excitable, and that the direction of its responsive movement is opposite to that of the lower half.

The characteristic of the response of the upper half is that not only is its sensitivity extremely feeble, but that its rate of reaction is very slow. The intensity of stimulus required for initiating response of the upper half is considerably greater than that for the lower half. Again, while the maximum contraction of the upper half was attained in the course of about 40 seconds, the lower half, as previously stated, exhibited its maximum contraction in the course of about 1.1 second. Taking these various facts into consideration, the excitability of the upper half may be regarded as at least 80 times less than that of the lower.

COMPARISON OF EXCITABILITY OF THE TWO HALVES
ON THE INTACT PLANT

I have devised an independent method for comparison of the excitability of the two halves. It will be shown in Chapter IX that *local* excitation can be induced in a tissue by the application of a constant current, and that this occurs under a feeble current at the kathode, that is to say, at the point where the current leaves the tissue.

Experiment 12.—Two electric connexions were made on the upper and lower halves of the pulvinus. By means of a reversing key the upper and the lower halves were successively made the kathode. It was thus found :

- (1) that the intensity of current which induced excitation of the lower half was insufficient to induce excitation of the upper half, proving the comparatively feeble excitability of the upper half ;
- (2) that on increasing the exciting current a point was reached when both the upper and lower halves underwent contraction ; the response of the former was a sluggish and relatively feeble up-movement, while that of the latter was a very quick and more energetic down-movement. I reproduce the two responses thus obtained, the up-movement of the upper half being represented by a down-curve, the down-movement of the lower half being, on the other hand, represented by an up-curve (fig. 22). The two curves clearly demonstrate the relative excitability and rate of reaction of the two halves of the organ.

The results given prove (1) that the upper half of the pulvinus does not contribute to the fall of the leaf ; (2) that both the upper and lower halves of the organ are contractile, the excitability of the lower being considerably greater than that of the upper half ; (3) that the contraction of the upper half is practically negligible compared

with that of the lower half ; (4) that under medium stimulation the lower half alone contracts, the upper exhibiting



FIG. 22. Curves showing differential excitability of upper (lower record) and lower half (upper record) of pulvinus of Mimosa.

little or no contraction ; (5) that under maximum stimulation both the upper and the lower halves contract and that, instead of the upper half helping the fall, it offers a feeble resistance to the fall of the leaf effected by the predominant contraction of the lower half of the pulvinus.

ELECTRIC DETECTION OF EXCITATORY REACTION

Experiment 13.—
I will anticipate certain results more fully described in a subsequent chapter (p. 164) in which it is

shown that excitation (as already mentioned) can be detected by an induced change to galvanometric negativity. On making suitable electric connexions with the upper and with the lower half of the pulvinus, it was found that strong stimulation induced excitation of both the upper and lower halves of the organ, the excitatory reaction of the lower being the more intense.

This is an additional proof of the antagonistic reactions of the two halves of the organ. The upper half, therefore, does not help in any way in the responsive fall of the leaf.

CHARACTERISTIC RESPONSES OF HIGHLY EXCITABLE
AND OF SUBTONIC PULVINUS

In highly excitable specimens the contractile fall of the leaf is maximum, whether the stimulus is moderate or strong. The response is here on the 'all or none' principle. But in less excitable or subtonic specimens a stronger stimulus is found to give rise to a larger amplitude of response (fig. 23). What can be the reason of this difference between



FIG. 23. Responses of a subtonic specimen of *Mimosa*.
Lower record in response to stimulus of 1 unit, and upper to
stimulus of 4 units.

the response of a highly excitable and that of a subtonic specimen?

It would appear that in a highly excitable specimen all the cells contract to their utmost, even under minimally effective stimulation; a greater contraction cannot, therefore, be produced under a stronger stimulation. In a subtonic specimen, on the contrary, increase in the intensity of stimulus up to the limit results in an increase of amplitude of response. This may possibly indicate that a relatively larger number of cells undergo contraction in a subtonic tissue under a stronger stimulus. This hypothesis is supported by the results of the following experiment.

DEPENDENCE OF AMPLITUDE OF RESPONSE ON THE
NUMBER OF THE EXCITED CELLS

Experiment 14.-- In attempting to modify the number of cells that undergo contraction, I applied the discovery that the contractility of the cells becomes effectively abolished on application of dilute solution of potassium chloride. When the solution is externally applied on the

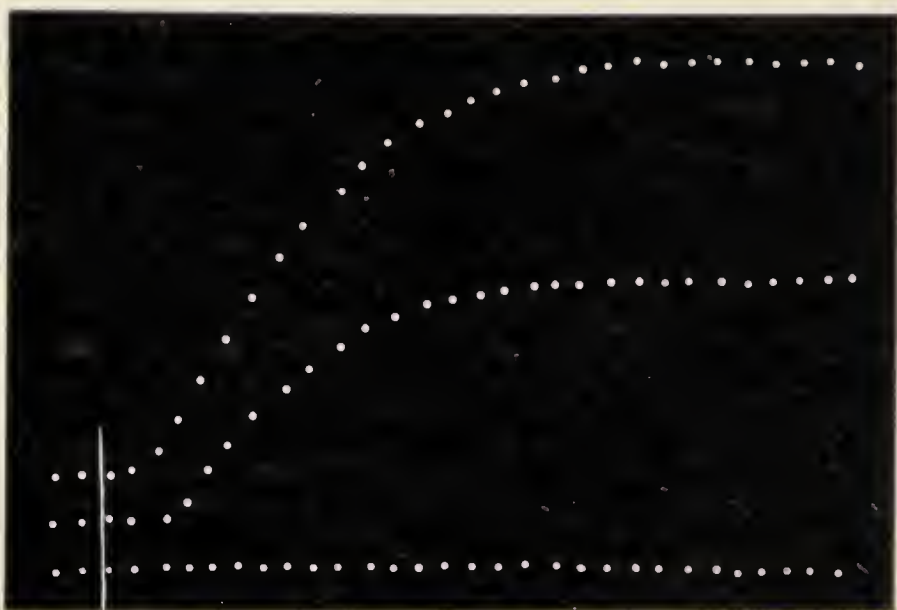

FIG. 24. Effect of the application of KCl solution on the pulvinus. Uppermost record, normal response; the intermediate record shows diminished contraction after absorption of KCl for 3 minutes; lowest record shows abolition of contraction after absorption for 18 minutes (Mimosa).

pulvinus it is gradually absorbed, and the outer layer of cells is naturally the first to be thrown out of operation; with longer duration of application the solution penetrates more deeply and renders an increasing number of cells ineffective. The effect of the duration of application of the solution in causing decrease in the total contraction is shown in fig. 24. The upper record is the response of the specimen, taken on a fast-moving plate, before the application of KCl, the amplitude of normal response being 40 mm. After recovery, 1 per cent. solution of KCl was applied to the pulvinus, and

the record of response was taken after an interval of 3 minutes. Even within this short period the amplitude of response was found to have been reduced from the normal 40 mm. to 20 mm., the reduction being nearly half. A third record was taken after a further period of 15 minutes. The solution had by this time penetrated throughout the pulvinus and produced the total abolition of response (fig. 24). The amplitude of response is thus seen to be dependent on the number of cells that undergo contraction.

HASTENING OF RECOVERY UNDER ENHANCED RATE OF ASCENT OF SAP

After a fall by contraction, the leaf slowly regains its original position by the gradual reabsorption of sap and restoration of the turgidity of the contracted cortical cells of the pulvinus. The most natural explanation of this would seem to be that the necessary fluid is supplied from the cortex of the stem, which will be shown later to be the important channel for the movement of sap. This finds support from the characteristic variation in the rate of recovery from stimulation in an identical *Mimosa* (1) when in a condition of incipient drought, and (2) when there is active ascent of sap after irrigation. In the first case the period of recovery was more than 20 minutes, while in the second case it was shortened to 8 minutes or so.

THE RATE OF WORK

The plant, like the animal, can be made to perform work in lifting weight by its excitatory contraction. In muscle, the work performed is found to increase to a limit under increased load and tension. Similar results are also obtained with *Mimosa*. Thus while under a load of 100 mgrms. the work performed was 4100 mm. mgrms.; it was increased to 26,000 mm. mgrms. under a load of 2000 mgrms. The rate of work was 7480 mm. mgrms. per second.

SUMMARY

In the pulvinus of *Mimosa* both the upper and the lower halves of the pulvinus are sensitive and contractile, the sensitiveness and contractility of the lower half being considerably greater than those of the upper.

A mechanical factor in the feeble erectile response under local stimulation of the upper half is the unequal pliability of the organ, which bends more easily downwards than upwards. Application of the same pull in the two directions produces greater curvature downwards.

When the plant is held in an inverted position, stimulation causes an erectile movement which raises the weight of the leaf against gravity. The normal fall of the leaf is therefore due not to flaccidity of the pulvinus but to active contraction of the lower half of the organ.

This active contraction is so great that the rapidity of the fall is practically the same whether it is helped by the weight of the leaf or opposed by an equivalent weight.

Removal of the upper half of the pulvinus has little or no effect on the rapidity of the fall of the leaf.

After removal of the lower half of the organ the leaf responds to stimulation by an erectile movement due to the contraction of the upper half. The sensitivity, the rate and the amount of contraction of the upper half are found to be very much less than those of the lower half. This result finds independent support from the effects of local stimulation of the upper and lower halves of the organ under the polar action of a constant electric current.

The factors of the weight of the leaf and of the action of the upper half of the pulvinus are, therefore, negligible compared with the active force of contraction of the lower half of the organ.

Under medium stimulation the lower half alone exhibits contraction, that of the upper half being practically absent.

The erectile recovery of the leaf of *Mimosa* is dependent on the rapidity of the flow of sap into the pulvinus, for recovery is hastened when the rate of ascent of the sap is enhanced.

The amplitude of the response is determined by the number of the cells that undergo contraction.

The work performed by the pulvinus is increased under an increased load. The rate of work performed by the pulvinus is found to be 7480 mm. mgrms. per second.

CHAPTER IV

CHARACTERISTICS OF MOTOR RESPONSE OF MIMOSA

HAVING described the motor mechanism of *Mimosa* in the previous chapter, it will be interesting to consider in some detail the characteristics of its responsive movements, as modified by successive stimulations and by the tonic condition of the plant.

Compared with other sensitive plants, the contractile reaction is most rapid in *Mimosa*. Its latent period, that is to say the interval between the impact of stimulus and the initiation of responsive movement, is comparatively short.

THE LATENT PERIOD

Experiment 15.—The latent period of a highly excitable *Mimosa* was determined by the Resonant Recorder, the successive dots being recorded at intervals of $\frac{1}{200}$ of a second. The responsive movement is seen to have occurred at the fifteenth dot, the latent period of the specimen being 0.075 second (fig. 25). In less vigorous specimens it may be as long as 0.12 second.

The maximum rate of contractile movement is attained in the course of about 0.2 second after the reception of the electric shock. The maximum contraction and fall of the leaf occur in about 1.5 second, after which gradual recovery takes place. From the results of electric investigation given in a later chapter, it would appear that the protoplasmic recovery is complete in the course of about 3 to 4 minutes. But the mechanical manifestation of this recovery is delayed

by the fact that it takes some time for the reabsorption of sap to produce expansion of the cortical cells and the full erection of the leaf. The maximum rate of erectile movement is about 260 times slower than the rate of maximum contractile fall. The recovery is completed in 8 to 20 minutes, depending on



FIG. 25. Record of latent period of *Mimosa* with a 200-vibration recorder. Shock at vertical line.

external conditions. Other things being equal, the recovery is protracted after stronger stimulation.

In regard to the stimulation of the pulvinus of *Mimosa* by induction-shock, a single break-shock, on account of its abruptness, is relatively more effective than a make-shock. A feeble shock, individually ineffective, can, moreover, be made effective by repetition, as demonstrated by the following experiment.

ADDITIVE EFFECT OF STIMULATION

Experiment 16.—A single make-and-break shock of intensity 0.5 unit was found in the particular specimen to be below the threshold of response. A reed-interrupter, tuned to vibrate five times per second, was interposed in the circuit of the primary of the induction-coil in order to produce a series of make-and-break shocks till the leaf responded by a fall. The electric signals below the record show that the singly ineffective stimulus of 0.5 became

46 CHAP. IV. CHARACTERISTICS OF RESPONSE OF MIMOSA
effective after four repetitions (fig. 26). The experiment
was continued with the same specimen with the intensity



FIG. 26. Additive effect of stimulus of intensity 0.5,
becoming effective on being repeated 4 times.

of stimulus reduced to 0.1; the stimulus had now to
be repeated 20 times before it became effective (fig. 27).

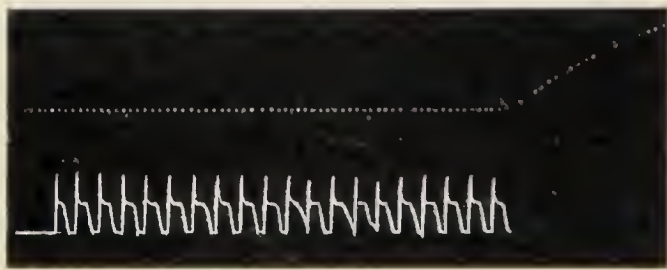

FIG. 27. Additive effect of stimulus of intensity 0.1,
becoming effective on being repeated 20 times.

Comparing the two results it is found that $0.5 \times 4 = 0.1 \times 20$; thus the number of additive stimulations requisite for effective excitation varies, within limits, inversely as the intensity of the stimulation employed.

UNIFORM RESPONSE

Experiment 17.—In normal specimens the responses are uniform under successive stimulations of constant intensity. The intervals between the successive stimulations must be long enough to ensure complete recovery. Fig. 28 shows uniform response to stimulation of moderate intensity, applied

at intervals of 15 minutes. The period of recovery, however, becomes prolonged, as already stated, under intense stimulation.

FATIGUE

Experiment 18.—When the recovery is incomplete the responses exhibit fatigue. The three initial responses

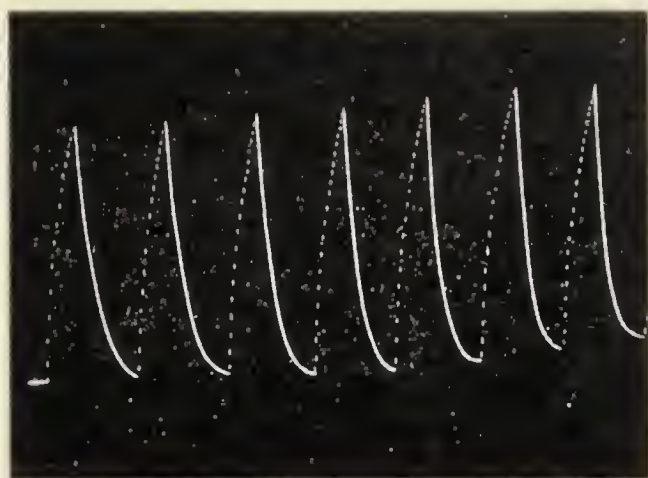

FIG. 28. Uniform responses of *Mimosa*; stimulus applied at intervals of 15 minutes.

(fig. 29) were obtained at intervals of 15 minutes between the stimulations. A reduction of the resting-period to 10 minutes resulted in fatigue as shown in the diminution of the amplitude of the next three responses. The response was restored to the normal after return to the original resting-period of 15 minutes.

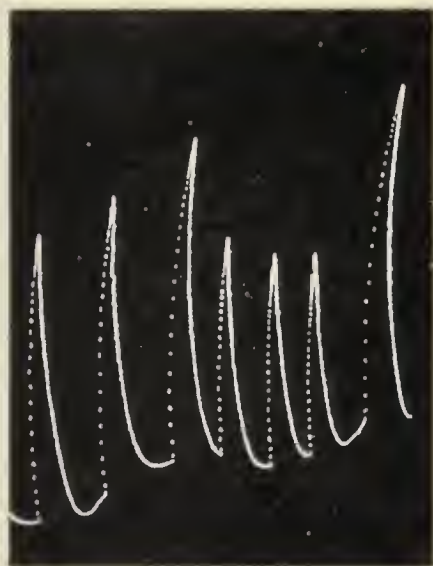

FIG. 29. Fatigue under shortened period of rest.

First three uniform responses obtained at intervals of 15 minutes. The second three, under shortened period of rest of 10 minutes, exhibit fatigue. On returning to interval of 15 minutes, the last record shows recovery, from fatigue.

FATIGUE-REVERSAL UNDER CONTINUOUS STIMULATION

The leaf of *Mimosa*, when subjected to continuous stimulation, at first exhibits the normal fall, followed by re-erection in spite of the stimulation which is still acting upon it. This appears paradoxical; but the apparent anomaly disappears when we recognise the essential similarity of responsive reaction in plant and animal. It is well known

that under continued electric stimulation the frog's muscle exhibits normal contraction followed by subsequent relaxation.

Experiment 19.—A reduction of the intervening period of rest has been shown to be followed by fatigue, the power of contraction undergoing marked depression. When the resting interval is greatly shortened the tissue becomes refractory, as it were, to further stimulation. An indication of this is seen in the record, given in fig. 30, of the effect of stimulation at intervals of 3 minutes; the responses subsequent to the first stimulation are seen to have been reduced



FIG. 30. Different phases in the fatigue-reversal in Mimosa.

Record of response to stimulation at intervals of 3 minutes (*see text*).

to a mere twitch. When the resting intervals are further reduced, as under continuous stimulation, the twitch disappears, and the leaf exhibits fatigue-relaxation.

There is an additional factor which may contribute to the erectile movement under continuous stimulation. The upper half of the pulvinus has been shown to be relatively unexcitable, on which account it requires a longer period of stimulation to undergo contraction contributing to an erectile movement of the leaf. This may conspire with the fatigue-relaxation of the lower half to produce the erectile movement under continuous stimulation.

DISSIPATION OF ENERGY IN RESPONSE

When Mimosa is in a vigorous condition, the feeblest stimulus precipitates the response. The leaf falls from a higher to a lower level, indicating a run-down or dissipation of energy. From this instance of 'trigger action' the conclusion has been drawn that the energy evolved must always be disproportionately larger than the stimulus that provoked it. The question arises whether this is universally

true and whether under other circumstances the energy of stimulation, instead of causing a run-down, may not actually raise the potential energy of the plant.

It should be borne in mind that living tissue is not merely a mass of matter but a higher complex of matter *plus* energy. The functional activity of the tissue depends on the previous absorption of energy from the environment, among which may be mentioned light, warmth, and chemical stimulants present in or absorbed from the soil. These environmental stimuli raise the tonic level of the plant, on which, as it will be presently seen, depend its diverse physiological activities. It will be shown in a future chapter that the continuous movement of sap is maintained in the plant by pumping action, which must necessarily require expenditure of energy which had been previously stored. Now when the plant is cut off from energy supplied by external stimulation, its tonic level falls *below par*; in this condition of subtonicity the movement of sap is found to become arrested. The lost power can be restored by fresh accession of energy from outside. What has been said of this rhythmical movement is equally true of other activities of the plant.

I will describe experiments regarding the effect of subtonicity on the contractile reaction of *Mimosa*. A simple method of obtaining a subtonic specimen is to isolate a branch of *Mimosa* and keep it in darkness with the cut end placed in water. In these circumstances there is a continuous lowering of motile excitability of the leaf, analogous to the depression of excitability in an excised muscle. Cut branches of *Mimosa* pass through various degrees of subtonicity; a specimen that has been detached for, say, 3 hours exhibits but slight depression, whereas others isolated for longer periods occupy correspondingly lower positions in the scale of subtonicity.

ERECTILE RESPONSE OF SUBTONIC SPECIMENS

I will first describe the response of *Mimosa* when in a condition of pronounced subtonicity, the specimen having been in an isolated condition and in darkness for 12 hours. The testing stimulus employed was either photic (Experiments 20, 21) or electric (Experiments 22, 23), both of which give similar results. The stimulus of light has certain advantages in causing moderate stimulation; it is, moreover, the stimulus to which the plant is subjected under natural conditions.

Experiment 20.—A beam of light from a small arc-lamp was thrown by means of suitably inclined mirrors on both the upper and lower surfaces of the pulvinus so as to cause diffuse stimulation. The response of the subtonic specimen was an *erectile movement* (fig. 31), *the leaf being raised from a lower to a higher level, indicating an increase of potential energy in the plant.* The positive or erectile response of the subtonic specimen indicates an accession of energy in contrast with the normal negative response connoting evolution and run-down of energy. The accession of energy will for convenience be designated as the A-reaction, the run-down of energy being described by the symbol D.

The tonic level of the subtonic tissue had been gradually raised towards the normal by absorption of energy supplied by external stimulation. What would be the character of the response during and after the transformation? The question is answered by the characteristic change in the response under successive stimulations described below.

TRANSFORMATION FROM POSITIVE TO NEGATIVE

Experiment 21.—Continuation of the last experiment gave very significant results. The first response, as already stated, was purely positive; the second was diphasic, positive followed by negative; the third, a slight positive twitch followed by a larger negative; the fourth was normal and enhanced negative (fig. 31).

How are we to account for this transformation? - It was the lack of stimulation that reduced the isolated specimen to a state of subtonicity with characteristic positive response. The energy that the tissue lacked was supplied by energy of successive stimulations, a portion of which must have been utilised by the tissue to raise its tonicity to the normal level with its characteristic negative response.

It shows, further, that the relative intensity of the two reactions, the positive A and the negative D, is modified in a definite manner according to the condition of the tissue; when the tonic level is *below par* the accession of energy A under stimulation is the more pronounced; when it is *above par* the depletion of energy D becomes accentuated. Since there is continuity between the positive and negative reactions, stimulation may be regarded as inducing both the A and D reactions, the resultant being $A - D$.

There is a significant fact noticeable in the record (fig. 31) showing the effect of the changing tonic condition on the attitude of the leaf. In the subtonic condition the pulvinus is abnormally relaxed. But after each stimulation there is a moderate residual contraction, the base-line of the record being thereby raised upwards, indicative of persistent contraction. The atonic expansion of the pulvinus is thus changed into improved tonus manifested by moderate contraction.

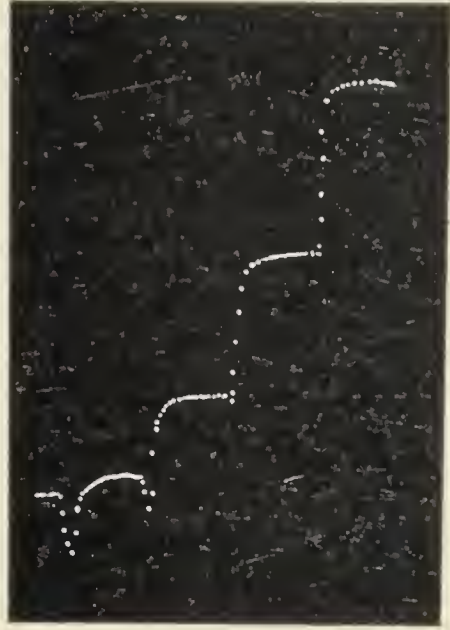

FIG. 31. Positive, diphasic, and negative response under successive photic stimulations in a subtonic specimen of *Mimosa*.

STAIRCASE RESPONSE

Experiment 22.—The energy absorbed from the incident stimulus does not merely end in a transformation of the abnormal positive response into the normal negative, but also increases the functional capacity of the tissue. This is illustrated in the record of the responses, to successive uniform electric stimulations (fig. 32), of a specimen which



FIG. 32. Staircase increase in successive responses of subtonic Mimosa.

was in a slightly subtonic condition. The successive responses in this case exhibit a staircase increase; the state of subtonicity is noticeable in that the first two responses exhibit a preliminary positive twitch which disappeared later.

A continuous transformation of the tissue from subtonic to normal condition under stimulation has been traced with a corresponding sequence of positive, diphasic, and staircase response. In this last case the change induced is from a feeble to a strong contraction. The question now arises: What further modification of response would there be after the impinging stimulus had raised the tissue to the optimum tonic condition?

CYCLIC VARIATION UNDER STIMULATION

Experiment 23.—The answer to the above question is to be found in the record (fig. 33) obtained with an intact Mimosa plant which was in a slightly subtonic condition, the stimulus being electric. The first three records in the series exhibit a staircase increase, the third response being

exceptionally large; after this intense excitation, which meant a considerable run-down of energy, the two succeeding responses exhibit a fatigue decline. The record of response of a frog's muscle (fig. 34) exhibits a similarity which is remarkable. Here also a series of stimulations at first gives a staircase increase which reaches a maximum.



FIG. 33.

FIG. 33. Staircase response followed by fatigue in *Mimosa*.



FIG. 34.

FIG. 34. Preliminary staircase followed by fatigue in the response of Frog's muscle (Brodie).

The subsequent responses exhibit a decline due to the onset of fatigue.

The following consideration offers a probable explanation of the cyclic change. The incident stimulus has been shown to give rise to two reactions, positive and negative, the relative values of which undergo variation according to the change of tonic level of the tissue resulting from stimulation. Starting with the tissue in a subtonic condition, the energy of incident stimulation is utilised in the internal work of raising the tonic level of the organ; at this stage there is no

stored energy for expenditure in negative response by contraction. As the tonic level gradually rises, the positive undergoes a diminution while the negative exhibits an augmentation; on the attainment of optimum tonicity the negative response is at its maximum. The expenditure and run-down energy is now too great for quick recuperation; the subsequent responses therefore exhibit fatigue.

ACCESSION AND DEPLETION OF ENERGY

To recapitulate, the protoplasmic reactions to external stimulation are the positive A and the negative D. The positive A is connected with the uphill work of storage and of the increase of potential energy of the system; the negative D is associated with the run-down of energy. The energy-content at any moment in the tissue is $A - D$, the algebraical sum of the work done *on* the plant in storage, and the work done by the plant in its response. The relative intensity of the two reactions, as already stated, is determined by the tonic condition, as summarised below.

TABLE II.—VARIATION OF RESPONSE UNDER CHANGE OF TONIC CONDITION.

Condition	Reaction formula	Accession or depletion of energy	Response
Subtonic	$A > D$	Accession greater than expenditure	Positive, diphasic and staircase
Normal	$A = D$	Accession equal to expenditure	Uniform
Optimum	$A < D$	Expenditure greater than accession	Maximum negative followed by fatigue

THEORY OF ASSIMILATION AND DISSIMILATION

The theories of assimilation and dissimilation of Hering and of anabolism and catabolism of Gaskell rest on the idea

of opposition between these two processes. Objections have been raised against the supposition that the phenomena are mutually exclusive, or that the increase of anabolism must necessarily result in a decrease of catabolism.¹ The experimental evidence from the response of *Mimosa* shows that the two processes, instead of being mutually exclusive, take place at the same time.

It is to be borne in mind that an identical reaction may be described from different points of view, from the responsive movement or from the chemical change that underlies it. For example, a plant in hypertonic or highly excitable condition (due to absorption of energy from outside) exhibits on stimulation an impulsive contractile fall or negative response of its leaf. This is associated with chemical breakdown, a process of catabolism. Now isolation of the plant from environmental stimuli reduces it to a subtonic condition which is characterised by a reversal of response from normal negative to abnormal positive. Under stimulation the subtonic leaf becomes erected against the force of gravity, the potential energy of the system being thereby increased. Unlike the predominant catabolic or breakdown process in the normal tissue after stimulation, the subtonic tissue exhibits a chemical change which must be of opposite sign—namely, of anabolic or building-up process.

The results of experiments described show that the subtonic tissue becomes energised by the impinging stimulus; the tonic level becomes raised, and the negative contractile response becomes increasingly pronounced till the predominant negative masks the positive. The existence of the two processes, and the predominance of the one or the other under different conditions, are clearly exhibited in the record given in figs. 31–34.

Among the diverse manifestations of protoplasmic irritability, as previously stated, are contractility, conductivity, and rhythmicity. It is interesting to find that

¹ Rayliss—*Principles of General Physiology* (1915), p. 421.

stimulation produces parallel changes in these different manifestations. The normal activity is maintained when the tissue is in favourable tonic condition by absorption of energy from the environment. In the subtonic condition, on the other hand, there is a depletion of energy, with the result that (1) the power of contraction disappears in a contractile tissue; (2) the power of transmission of excitation is arrested in a conducting tissue; and (3) the automatic power of repeated contraction in a rhythmic tissue comes to a state of standstill, as will be shown later. Stimulation revives these different manifestations in a staircase manner.

SUMMARY

Stimulations, individually ineffective, become effective on repetition. Within limits, the number of additive stimulations for effective excitation varies inversely as the intensity of the stimulus employed.

The contractile response of the motor organ of *Mimosa* exhibits characteristics similar to those of animal muscle.

The responses show fatigue under conditions of incomplete recovery from excitation.

The anomalous erection, after preliminary fall of the leaf of *Mimosa* under continuous stimulation, is explicable on the common characteristics of response in animal and plant tissues. In both, contraction is reversed to relaxation under continuous stimulation.

The responsive reaction in *Mimosa* is not of one but of two kinds: positive and negative. The positive A is associated with accession, and the negative D with run-down of energy, the resultant effect being $A - D$. The contractile fall of the leaf is associated with evolution of energy which had previously been stored in the tissue. The plant isolated from environmental stimulation falls into a subtonic condition, when its power of contraction disappears.

Stimulation effects both internal and external work, the relative values of which undergo progressive change. In

the condition of subtonicity the energy of incident stimulus is utilised in raising the tonic level and in increasing the functional activity of the tissue ; in this stage the response to stimulation is purely positive, indicative of absorption of energy. In the intermediate stage the response is diphasic, positive followed by negative, with staircase increase of the negative response. In the optimum condition attained by absorption of energy from external sources the negative response becomes disproportionately larger than the impinging stimulus that occasions it. The ' trigger action ' is only a particular event in the tonic cycle.

CHAPTER V

THE 'ACTIVE SUBSTANCE' IN QUICKLY CONTRACTILE TISSUES

THE active movement of life has been shown to be brought about by expenditure of energy that had previously been stored in the organism. It is the energy-content of the organism that has been conveniently designated as its tonic condition. The experiments described in the previous chapter conclusively proved that the contractility of the pulvinus and the resulting fall of the leaf disappear when the tissue passes into the subtonic condition. The essential condition for motility is therefore a favourable tonic condition, as already defined.

There are other peculiarities exhibited by the motor organs; thus pulvini of different species of plants show characteristic differences in their sensitiveness as well as in the rate and extent of their contractile movements. Three types of pulvini may conveniently be distinguished—'Active,' 'Semi-Active,' and 'Inactive.' *Mimosa* represents the first, *Neptunia* the second, and *Erythrina* the third type. *Erythrina* may be taken as representative of the relatively inactive pulvini of many leguminous plants such as the Bean-plant (*Phaseolus*).

ACTIVE, SEMI-ACTIVE, AND INACTIVE PULVINUS

The active pulvinus of *Mimosa* responds to an electric stimulus as feeble as 0·1 unit, while the minimal stimulus necessary to initiate response in that of *Neptunia* is 2 units,

and in that of *Erythrina* it is about 4 units. On application of the maximal stimulus in the three cases, the extent of the responsive movement is found to be very different. The normal outspread position of the leaf of *Mimosa* is from 10° to 15° above the horizon; on stimulation it executes an angular fall of nearly 100° in the course of about 1.5 second, which may be taken as the average value. In *Neptunia* the maximum fall of 15° is attained in the course of 180 seconds. Finally, in *Erythrina* the extent of the movement is through only 0.8° , necessitating a moderately high magnification in order to obtain a suitable record; the maximum fall in this case is attained in the course of 480 seconds.

TABLE III.—RATES OF CONTRACTILE REACTION OF ACTIVE, SEMI-ACTIVE, AND INACTIVE PULVINI.

Specimen	Period of maximum fall	Angular movement of fall (in degrees)	Rate of fall per second (in degrees)
<i>Mimosa</i> . . .	1.5 second	100.0	66.0
<i>Neptunia</i> . . .	180 seconds	15.0	0.08
<i>Erythrina</i> . . .	480 seconds	0.8	0.002

The rate of the responsive movement of *Mimosa* is seen to be about 800 times more rapid than that of *Neptunia*, and 30,000 times than that of *Erythrina*.

What can be the cause of this difference? In considering responsive movements, two different elements have to be taken into account—first, the power of contraction, and second, the rapidity of contraction. The power of contraction has been shown to be essentially dependent on the tonic condition, since a subtonic tissue exhibits no contraction. But however favourable the tonic condition may be, it cannot make a semi-active or inactive tissue contract as rapidly as the active tissue of *Mimosa*. The rapidity of contraction must be due to some other hitherto unsuspected factor.

ANATOMY OF THE PULVINUS

A longitudinal section of the petiole and the pulvinus of *Mimosa* is shown in fig. 35. There are four main vascular bundles in the petiole, which are there separate from each other, but converge and meet in the pulvinus. The pith becomes thereby reduced and the cortex increased proportionately. The two bundles, upper and lower, in the section are seen to approach each other in the pulvinus.

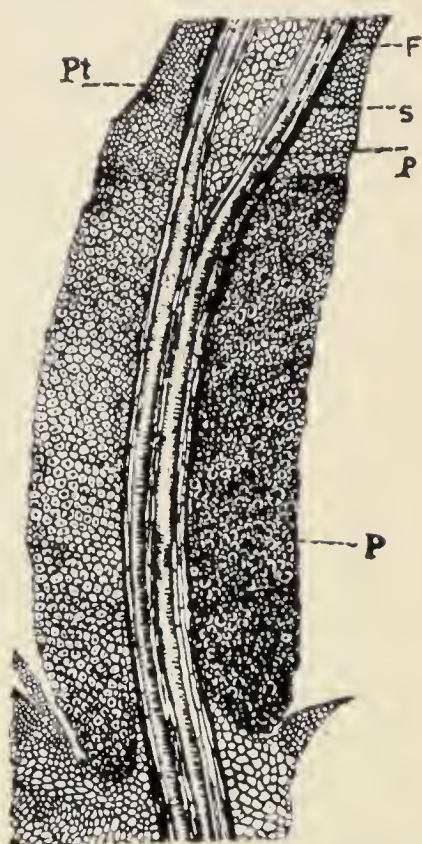

FIG. 35. Longitudinal section of petiole and pulvinus of *Mimosa* passing through the upper and lower vascular bundles.

pt, the cortical cells of the petiole which remain unstained. Lower P to the right indicates contractile cells of pulvinus which become deeply stained.

It is remarkable that though the rapid movement of the leaf is effected by the contractile cells of the pulvinus, yet these active cells present no special features of structure by which they can be distinguished under the microscope. They do not differ in any important respect from the relatively inactive cells of the pulvinus of the Bean-plant. Again, in the pulvinus of *Mimosa* itself it is impossible to detect, by microscopic examination, the place where the active cells begin or end, and how they are distributed.

DETECTION OF 'ACTIVE SUBSTANCE' IN THE CONTRACTILE TISSUE OF MIMOSA

It appeared probable that the rapidity of the contractile reaction might be due to some special modification of the

protoplasmic contents of the active cells. If so, the difference between the active and inactive cells might be revealed by the action of suitable chemical stains and developers.

Experiment 24. *Localisation of actively contractile cells by Hæmatoxylin and Safranin developer.*—As previously stated, it is impossible, even under microscopic examination, to find the line of demarcation between the inactive cortical cells of the petiole and those of the actively contractile pulvinus. Double-staining of the longitudinal section of the pulvinus of *Mimosa* produced a most remarkable result (*cf.* fig. 35). It appeared as if a hand had picked out, with the utmost care, every contractile cell and painted its protoplasmic contents deep red. The contents of the cortical cells of the petiole remained unstained. The line of demarcation between the active cells of the pulvinus and inactive cells on both sides of the petiole is now well defined. Under careful application of the reagents, the depth of staining of the lower half of the pulvinus appeared to be greater than that of the upper half. The very deeply stained cells in the lower half of the pulvinus were numerous and appeared compactly arranged, whereas in the upper half they were relatively few and scattered in their distribution.

Experiment 25. *Safranin.*—Safranin may be employed alone. Prolonged application of a dilute solution stains the protoplasmic contents of the active cells deep red. This stain brings out certain interesting characteristics of the cell-contents to be presently described.

Safranin and Light Green developer.—These also produce a great contrast between the active and inactive cells. While the protoplasmic contents of the active cells alone are stained deep red, the inactive cortical cells of the petiole (or rather their cell-walls) are stained green.

Experiment 26. *Methylene Blue and Erythrosin.*—The sections are immersed in strong alcoholic solution of methylene blue; after washing in absolute alcohol they are immersed in erythrosin dissolved in olive oil. The staining has to be stopped at the right moment. The contents

of the active cells are stained deep blue, while the inactive cortical cells are stained red.

Experiment 27. *Hæmatoxylin and Bismarck Brown*.—A deep brown staining discriminates the active from the inactive cells.

Experiment 28. *Iodine Green and Alum-Carminc*.—A sharp contrast is brought about between the active and inactive cells of the cortex, the former being stained vivid green, while the latter become pink.

The various stains thus discriminate the active from the inactive cells in the same petiole-pulvinar preparation, and indicate that the difference depends upon the presence of a substance in the former which is absent in the latter.

STAINING OF THE SEMI-ACTIVE PULVINUS

Experiment 29.—Application of stains to the longitudinal section of the pulvinus of the semi-active *Neptunia* brought out a significant difference between active and semi-active motor organs. In *Mimosa pudica* the active cells which become stained are compact and extend almost to the central vascular strand. But in *Neptunia* the stained cells extend barely to one-third the thickness of the cortical tissue of the pulvinus. There are, moreover, large patches of cells in the pulvinus which remain unstained.

EFFECT OF STAINS ON INACTIVE PULVINI

Experiment 30.—No staining occurred in the pulvinar cells of the inactive Bean-plant and of *Erythrina*, the substance which undergoes staining being here altogether absent.

STAINING OF DIFFERENT PULVINI OF THE SAME PLANT

Experiment 31.—In *Mimosa Spegazzinii* the primary pulvinus of the leaf is very feebly sensitive, whereas the

secondary pulvini of the leaflets are highly excitable. I first tried the specific action of the dyes on sections of the primary pulvinus; only a few cells here and there became stained. Application of the reagents to the secondary pulvinus, however, produced deep staining of all the cortical cells of the motor organ. The high sensitiveness of the leaflets is therefore associated with the abundance of the stainable substance in the active cells and their greater number.

THE SCALE OF EXCITABILITY

I carried out experiments with the object of discovering the order of excitability in different pulvini, from the highly active to the inactive through intermediate gradations. The different types can be placed under four headings, viz. the active, the semi-active, the feebly active, and the inactive. The change from one group to the next is not abrupt, but gradual. The most active is (1) the primary pulvinus of *Mimosa*. The next in order are the secondary pulvini (2) of *Mimosa Spegazzinii*, (3) of *Biophytum*, and (4) of *Neptunia*. Under the semi-active class come (5) the primary pulvinus of *Neptunia* and (6) the secondary pulvinus of *Averrhoa*. The feebly active is represented by (7) the primary pulvinus of *Mimosa Spegazzinii*. The inactive organs include the primary pulvini (8) of *Averrhoa*, (9) of *Erythrina*, and (10) of the Bean-plant (*Phaseolus*).

It is highly significant that the distribution of the stainable substance closely follows the above order (see Table IV).

Inasmuch as there is shown to be a direct relation between the activity of the pulvinus and the amount of stainable substance in its contractile cells, it may be concluded that this stained substance is directly related to the rapidity of contraction, that it is, in fact, an active substance.

I reproduce photo-micrographs of portions of the lower half of the pulvinus of *Mimosa*, of *Neptunia*, and of the Bean-plant (fig. 36).

TABLE IV.—SHOWING DISTRIBUTION OF STAINABLE SUBSTANCE IN DIFFERENT PULVINI.

Pulvinus	Contractile organ	Distribution of stained active cells
Active	1. Primary pulvinus of Mimosa 2. Secondary pulvinus of <i>M. Spegazzinii</i> 3. Secondary pulvinus of Biophytum 4. Secondary pulvinus of Neptunia	Cells deeply stained and forming a compact tissue
Semi-active	5. Primary pulvinus of Neptunia 6. Secondary pulvinus of Averrhoa	Scattered distribution of stained cells
Feebly active	7. Primary pulvinus of <i>M. Spegazzinii</i>	Only a few stained cells
Inactive	8. Primary pulvinus of Averrhoa 9. Primary pulvinus of Erythrina 10. Primary pulvinus of Phaseolus	No cells stained

Granular character of protoplasm.—Another modification, probably of much significance, is the granular character of

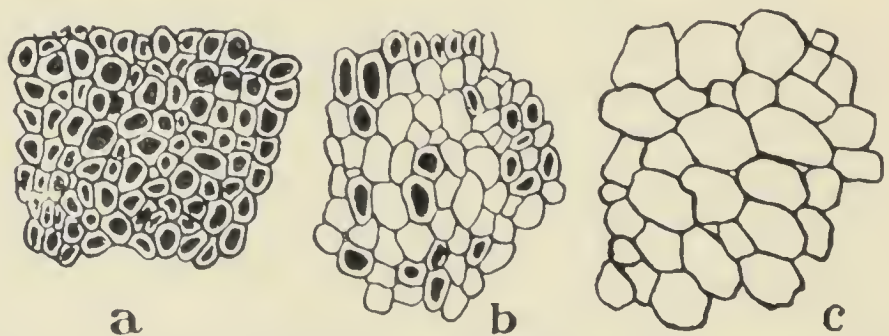

FIG. 36. Reproduction of photo-micrographs of portions of the pulvini of: (a) active Mimosa, (b) semi-active Neptunia, and (c) inactive Bean-plant. The stained content of the contractile cells represented dark.

the contents of the active cells observed under high magnification in the safranin-stained tissue. It is possible to

observe a large number of grains in the protoplasmic contents of the 'active' cells in which they occur.

In regard to the semi-active pulvinus, the distribution of the active cells is not only scattered, but the granular character of the protoplasm appeared to be less marked. In the inactive pulvinus the protoplasm is not granular and, as already stated, remains unstained.

ACTIVE AND RELATIVELY INACTIVE ANIMAL MUSCLE

It is remarkable that the powerful contraction of animal muscle is also dependent on the presence of a certain plasmatic substance—the granular sarcoplasm. This is well



FIG. 37. Transverse sections of pectoral muscles of (a) the falcon, (b) the goose, and (c) the domestic fowl. The relative amount of granular substance (shown as shaded) varies directly with the bird's power of sustained flight (after Knoll).

seen in the transverse sections of the pectoral muscles of the falcon, the goose, and the domestic fowl, in which the relative amount of the granular substance varies directly with the bird's power of sustained flight (fig. 37).

Inquiries into the character of the 'active substance' in plants are still in progress; several questions require further elucidation. I here describe the results which have already been secured.

The presence of the active substance in large quantity is associated with the extraordinarily rapid acceleration of the contractile reaction. The contraction is probably brought about through one or more intermediate processes, ending ultimately in oxidation, combustion, and production of

carbon-dioxide.¹ It will be shown that the contractile reaction takes place only in the presence of oxygen, and becomes arrested in an atmosphere of carbonic acid gas (Experiment 38, p. 73). The active substance would appear to be highly oxidisable, such as would absorb oxygen from all available sources. It should, therefore, be capable of reducing oxides.

MICRO-CHEMICAL TESTS OF THE 'ACTIVE SUBSTANCE' IN THE PULVINUS

Experiment 32. *Reaction with Osmic acid.*—This particular oxidising agent was rapidly reduced by the protoplasmic contents of the active cells into a lower oxide which produced a dark stain. The contrast between the active and inactive cells is as strongly marked as that produced by double-staining.

The staining could still be obtained after treatment of the prepared section with cold or warm alcohol or ether. The 'active substance' cannot, therefore, be a fat or a lipid; it still contained a powerful reducing group, characterised by double or triple bonds. This is justified by the fact that no staining was obtained after bromination, which converts an unsaturated into a saturated compound.

The activity of the modified protoplasm is therefore dependent upon the presence of a highly reactive and oxidisable substance, an unsaturated compound with double or triple bond-combinations.

SUMMARY

The contractile reaction is associated with run-down of energy. It can only take place when the tissue is in a

¹ The contraction of the animal muscle is a very complex phenomenon, supposed to take place through two distinct processes. 'The energy required for the second process is afforded by a reaction in which some substance, carbohydrate or fat, is oxidised. Much oxygen is used and carbon-dioxide given off.'—Bayliss, *Principles of General Physiology*, p. 461.

favourable tonic condition, by which is meant its previous absorption of energy from external sources. An atonic tissue loses for the time being its power of contraction.

There is an additional factor which determines the *rapidity* of contraction. This is the presence of an active substance in the contractile cells. The rapidly contractile cells are demarcated from others by the differential action of stains.

It is shown that the distribution of the stainable active substance affords a measure of the rapidity of contraction of the motor organ. In the semi-active *Neptunia* the active cells are more sparsely distributed than in *Mimosa*. The inactive pulvini contain no trace of the active substance. The plasma of active cells exhibits a marked granular character.

The energy for rapid movement must be ultimately derived from a catabolic process of combustion, using that term in its wider sense. The active substance is shown to be highly oxidisable, being an unsaturated compound with double or triple bond-combinations.

CHAPTER VI

EFFECTS OF EXTERNAL AGENTS ON RESPONSIVE MOVEMENT OF MIMOSA

THE question has already been raised whether or not the contractile reaction of the plant is fundamentally similar to that of the animal. The prevailing belief has been that the two phenomena are very different. It must have been the want of proper means for the accurate analysis of plant-response and its induced variations that led to this wrong conception. New devices and instruments have now removed all experimental difficulties. The results already given show that the phenomenon of contractile response in the plant is essentially similar to that in the animal. Both exhibit, under parallel circumstances, a similar staircase increase of response on stimulation when in the condition of subtonicity, and a similar decrease of response under fatigue. The effects of drugs, of narcotics, and of poisons will presently be shown to be very similar in the two cases. Finally, the power of quick reaction is found in both to be due to the presence of some active substance. The physiological mechanism in the two cases would thus appear to be fundamentally similar. The simpler reaction of the plant may therefore be expected to throw light on the more complex reaction of the animal.

There is a very special advantage offered by the plant which arises from the relative slowness of its reactions. For example, the latent period of the pulvinus of *Mimosa* is about forty times longer than that of frog's muscle; moreover, the phase of contraction of the muscle lasts $\frac{4}{100}$ of a second, in contrast to the longer period of 1.1 second of

the pulvinus. It thus happens that, in consequence of instrumental inertia, the course of events in a rapid muscular twitch is very inaccurately reproduced in the record. When under certain circumstances there are two opposite responses rapidly following each other—a short-lived and feeble positive followed by a stronger negative—then the record of the former will be completely obliterated by the latter. It is through the fortunate circumstance of the relatively slow reaction in the plant that it has been possible to demonstrate the important fact that stimulation gives rise to a double response, a positive and a negative.

I proceed to describe the effects of variation of light, of turgor, of temperature, and also of the action of drugs on the responsive movement. A series of normal responses is first obtained under uniform stimulation; then the effect of any given agent is observed in the variation induced in the amplitude of response.

The experiments were carried out in an open veranda under uniform intensity of light.

EFFECT OF THE VARIATION OF LIGHT

Experiment 33.—*Mimosa* is extremely sensitive to variations of light. Even a passing cloud induces a marked

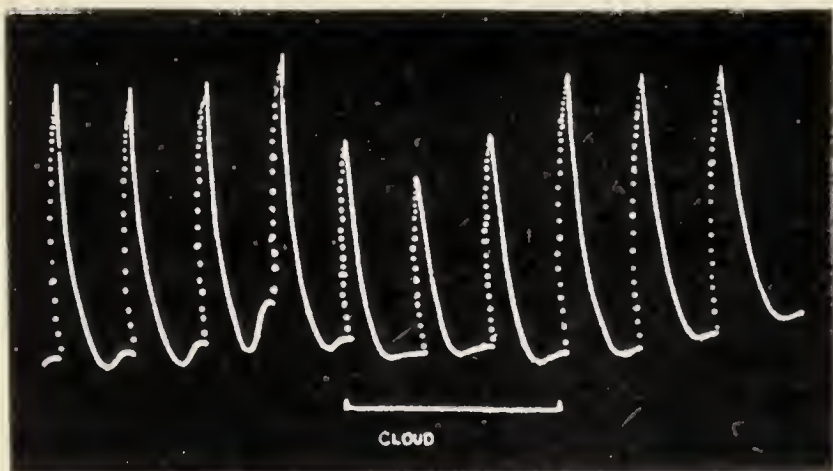

FIG. 38. Depressing effect of a passing cloud on the response of *Mimosa*.

change in the excitability of the motor organ. This is clearly shown in the record (fig. 38), in which the first four are the normal uniform responses; the next three show the depression induced by slight darkening due to the passage of a cloud across the sky. The sky cleared and the subsequent responses indicate restoration of the normal moto-excitability.

INHIBITION OF CONTRACTION BY EXCESSIVE ABSORPTION OF WATER

Various sensitive plants, growing in the open, are found to lose their moto-excitability on rainy days. This loss of

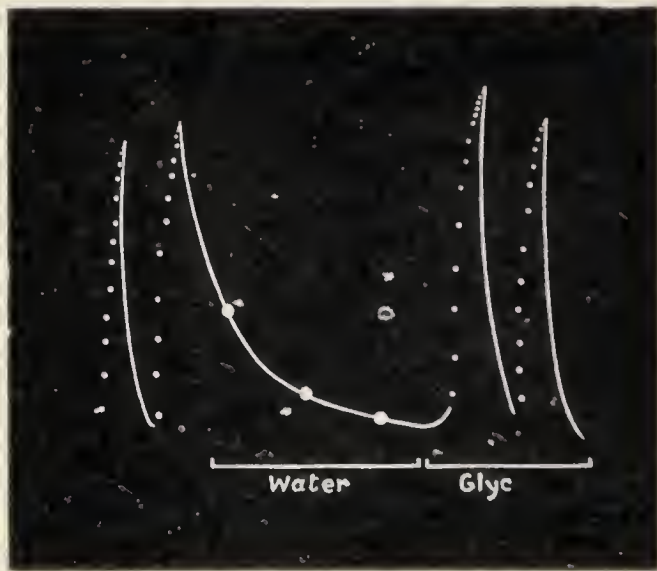

FIG. 39. Abolition of moto-excitability of pulvinus of *Mimosa* by excessive absorption of water. Note prolongation of period of recovery and ineffectiveness of stimulations applied at moments marked with thick dots. Subsequent restoration of excitability by application of glycerine.

motility I was able to trace to the water-logged condition of the pulvinus. It should be remembered that water-logged muscle also loses its power of contraction.

Experiment 34.—The effect of excessive absorption of water on response is shown in fig. 39. After taking a pair of normal responses, a drop of water was applied on the pulvinus during recovery from the second stimulation.

Testing stimuli were applied at the usual interval of 15 minutes, the moments of application being represented by thick dots. These stimulations failed to induce any responsive movement.

The probable explanation of the phenomenon is as follows: first, abnormal distension of a cell paralyses its power of contraction, as in muscle; secondly, contraction being possible only by expulsion of sap into neighbouring cells, this cannot take place when all the cortical cells are already in a state of the utmost distension.

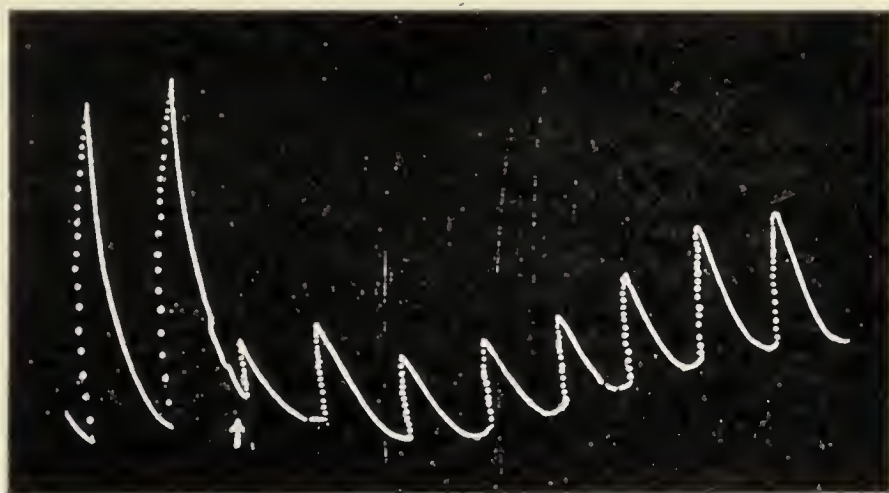

FIG. 40. Effect of moderate absorption of water. First two responses normal. Application of water, at arrow, induced depression of moto-excitability (*Mimosa*).

I next attempted to restore the arrested power of contraction by artificial means. Since glycerine has the power of abstracting water, a drop of this substance was applied to the pulvinus. This resulted in a quick restoration of the normal contractility, the two responses after the application of glycerine being practically similar to those at the beginning of the series.

Experiment 35.—In another experiment the increase of turgor produced by brief application of water was not so excessive; but it sufficed to produce great depression of moto-excitability, as shown in fig. 40. The record was continued for 2 hours, when the motility was found to be

slowly regained, evidently by the restoration of normal turgor through movement of sap from the excessively turgid to a less turgid region.

EFFECT OF THE VARIATION OF TEMPERATURE

The plant is enclosed in a chamber, with a transparent glass or mica cover ensuring uniform illumination. An electric device is employed for varying the temperature of the plant-chamber, which is maintained in a proper humid

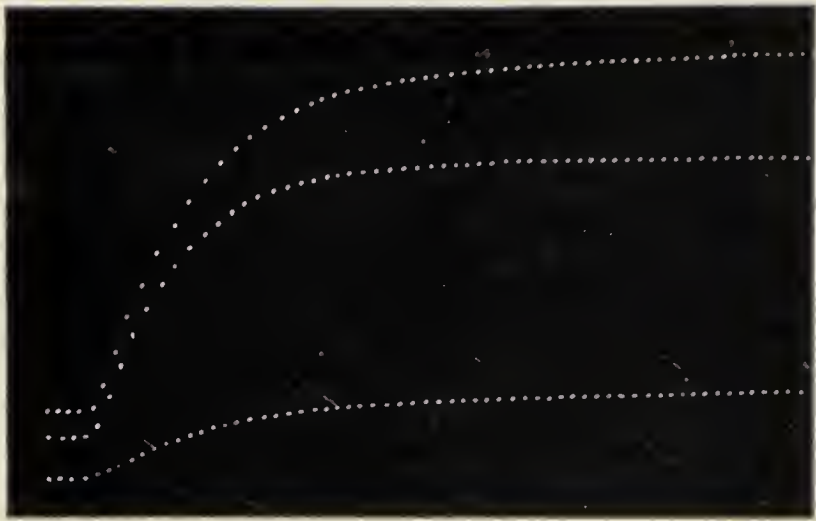

FIG. 41. Responses taken on a fast-moving plate, at three different temperatures, 22° , 27° , and 32° C., the lowest below and the highest above. Amplitude of response larger and steepness of curve greater at higher temperature (Mimosa).

condition. An electric current from a battery outside is led through a coil of heating-wire inside the chamber. The heat generated can be regulated by varying the intensity of the current. The temperature inside the chamber can thus be raised to any desired degree, and maintained constant during the period of the experiment.

Experiment 36.—Three records on a fast-moving plate were obtained at three temperatures of 22° , 27° , and 32° C. The amplitude of response is seen to be progressively increased under the rising temperature. The rate of contraction is more rapid at the higher temperature, as is seen in the increased steepness of the curve (fig. 41).

The amplitude of response reaches its maximum between 34° and 35° C., which may therefore be taken as the optimum; a further rise of temperature induces a depression, which also occurs on lowering the temperature below the normal (*see* fig. 54, p. 94). The minimum temperature for the abolition of motor response in *Mimosa* in the tropics is about 18° C.

The effects of different gases and vapours are described below. For subjecting the plant to the action of different gases and narcotic vapours, the plant is enclosed in a glass chamber with an inlet and an outlet pipe. Gases and vapours can be pumped into the chamber, air being expelled by the exit pipe. In order to observe the after-effect, the chamber can be filled with fresh air. The plant exhibits revival from temporary depression or narcotisation; but if the narcotic dose has exceeded the safety limit, or if the gas has been too poisonous, death supervenes without possibility of revival.

EFFECT OF OZONE

Experiment 37.—The stimulating effect of this gas is clearly visible in fig. 42. The particular leaf was showing signs of fatigue; the introduction of ozone into the plant-chamber brought about an immediate change, inducing an enhancement of excitability indicated by the increased amplitude of response.

EFFECT OF CARBONIC ACID GAS

Experiment 38.—In contrast to the stimulating effect of ozone is the asphyxiating action of a

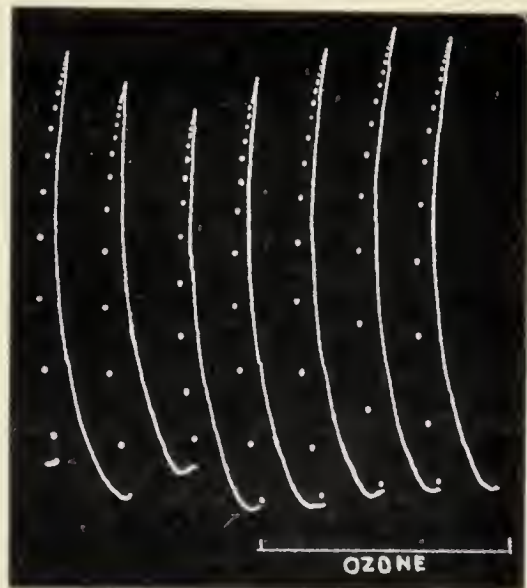

FIG. 42. Stimulating action of Ozone (*Mimosa*).

large dose of CO_2 , which causes the moto-excitability of the pulvinus to undergo a depression. It is probable that there is a reserve of oxygen in the tissues for the maintenance of the oxidative processes of organic decomposition, upon which the evolution of energy depends. Hence replacement of the air in the plant-chamber by undiluted carbonic acid gas may not be immediately followed by total abolition of excitability. The depressing effect of CO_2 is, however, quite evident in the rapid diminution of the

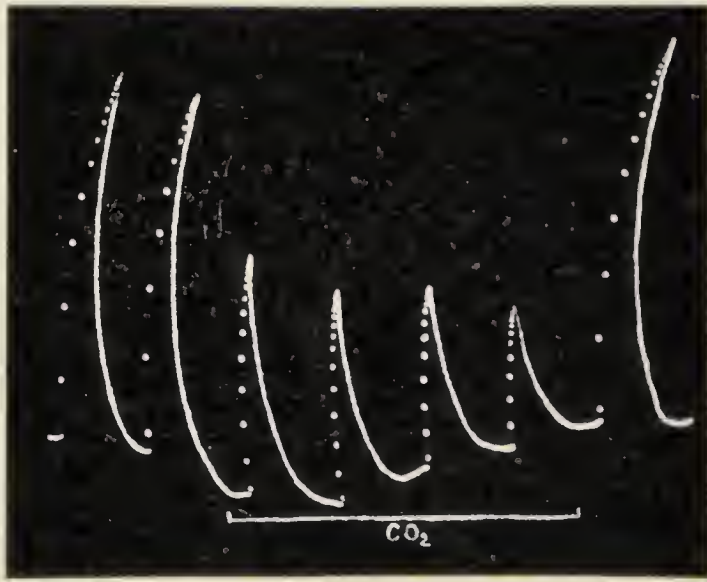

FIG. 43. Effect of Carbonic Acid Gas (*Mimosa*).

amplitude of response (fig. 43). A noticeable feature in the record is the displacement of the base-line upwards, indicating persistent contraction. When the plant-chamber was refilled with fresh air, the normal excitability was restored.

While a large dose of CO_2 causes depression, a small dose induces an enhancement of excitability. This explains why, under continued action of dilute CO_2 , the response exhibits a preliminary enhancement, followed by a decline (*cf.* fig. 70).

EFFECT OF SULPHURETTED HYDROGEN

The normal irritability of plants is greatly depressed by the vitiated air of a town. The effect of this on certain

plants is most marked. For example, *Biophytum sensitivum* grows as a weed seven miles outside Calcutta, and exhibits great sensitiveness to all modes of stimulation. But after removal to town it loses its irritability in a short time and succumbs in the course of a few weeks. I find that some of the impurities present in the town air, such as traces of H_2S and of SO_2 , are very deleterious to the normal irritability of the plant.

Experiment 39.—The presence of sulphuretted hydrogen in the air of towns is perhaps the most harmful. This is illustrated in fig. 44. The introduction of this gas into the plant-chamber caused the period of recovery to become greatly protracted. The abolition of excitability is evidenced by the fact that successive stimulations at the points marked with thick dots proved to be quite ineffective. The action of this gas is so poisonous that restoration to fresh air did not bring about any revival. The plant was subsequently found to have died from the poisonous effect of the gas.

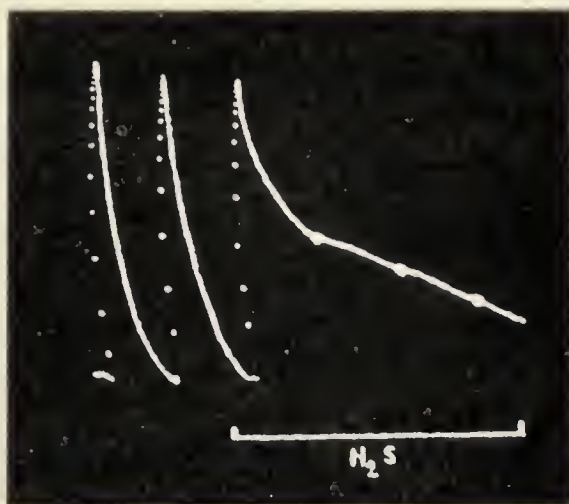

FIG. 44. Total abolition of excitability and death of plant under the action of Sulphuretted Hydrogen (Mimosa).

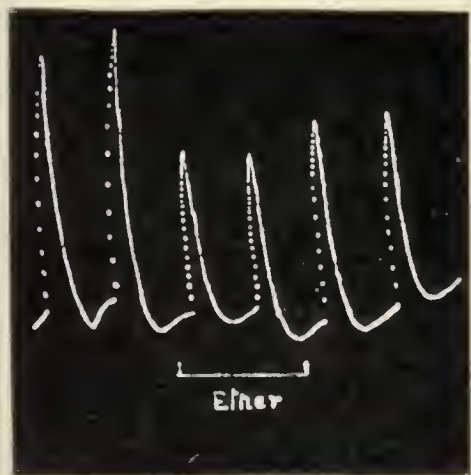

FIG. 45. Effect of Ether (Mimosa).

EFFECT OF ETHER

Experiment 40.—The continued action of ether induces a depression of excitability, as is seen in the reduction of the amplitude of successive responses. The depressing effect of this narcotic passes off on the readmission of fresh air (fig. 45).

CHLOROFORM

Experiment 41.—The vapour of chloroform acts as a very strong narcotic, and any excess of its application proves fatal. In fig. 46 is shown the effect of a large dose of chloroform on the plant. This not only produced a total abolition of excitability, but brought about a sudden spasm, which was the spasm of death, seen as a line shooting upward. After this, the blowing off of the vapour failed to revive the plant.

In carrying out this investigation I became aware of



FIG. 46. Abolition of excitability under Chloroform (*Mimosa*).

the relation of the dose to the reaction. An agent which in large doses proves to be toxic is found to be stimulating when given in minute quantities. The absorption of chloroform vapour being slow, the immediate effect is that of a small dose, shown by an enhancement of the amplitude of response. Continued application produces, however, the depressing action of a large dose (*see* fig. 71).

I carried out further experiments on the action of other gases and vapours. Ammonia was found to depress excitability, which was slowly restored after removal of the vapour. The vapour of carbon disulphide produced depression, the response showing increasing relaxation. When the application had not been too prolonged, fresh air revived the normal excitability. Nitrogen dioxide is, on the other hand, extremely poisonous.¹

The effects of various drugs in solution will be described in the next chapter.

¹ *Irritability of Plants* (1913), p. 96.

SUMMARY

A diminished intensity of light induces depression of excitability.

Excessive turgor inhibits moto-excitability.

Excitability is increased under rise of temperature up to an optimum, which is about 34° C. ; depression sets in above this optimum. Lowering of temperature induces depression and the excitability disappears at the critical point, which is about 18° C. in the tropics.

Chemical agents induce parallel modifications of response in plant and in animal tissues.

Ozone induces an enhancement of excitability.

Asphyxiation by CO_2 causes a great depression of excitability, which is restored on the readmission of fresh air. Small doses of CO_2 induce a transient enhancement of excitability.

Sulphuretted hydrogen causes abolition of excitability and the death of the plant.

Vapour of ether exerts a moderate narcotic action, inducing a temporary abolition of excitability, which is restored on the readmission of fresh air.

Chloroform is a stronger narcotic ; excess of it causes the death of the plant.

A minute dose of a toxic agent is often found to have a stimulating action.

CHAPTER VII

THE PETIOLE-PULVINUS PREPARATION OF *MIMOSA* *PUDICA*

THE most suitable plant for researches on irritability is *Mimosa pudica*, which can be obtained in all parts of the world. An impression unfortunately prevails that the excitatory reaction of the plant can be obtained only in summer and under favourable circumstances, thus militating against its extensive use in physiological investigation. This misgiving is, however, without any foundation, for I found no difficulty in demonstrating even the most delicate experiments with *Mimosa* before the meeting of the American Association for the Advancement of Science held in the United States about Christmas in 1914. The prevailing outside temperature at the time was considerably below freezing-point. With foresight and care it is not at all difficult to maintain in a hothouse a large number of these plants in a sensitive condition all the year round.

In order to remove the drawback connected with the supply of sufficient material, I carried out an investigation to ascertain if a cut shoot would prove to be as efficient for the study of irritability as the whole plant: to ascertain, in fact, if an isolated petiole-and-pulvinus preparation of *Mimosa* would not be as efficient for researches on irritability as the nerve-and-muscle preparation of a frog.

The petiole-pulvinus preparation is made by isolating a piece of a stem bearing a single leaf. The apex of the stem and the four diverging sub-petioles of the leaf may also be cut off. The upper cut end of the piece of stem, and the cut

end of the petiole are covered with a moist cloth or with collodion flexible to prevent drying up. The lower cut end of the stem may also be covered with a piece of moist cloth ; but for experiments of long duration it is advisable to mount it in a T-tube, with a funnel and exit-tube for the introduction and removal of water or any chemical solution. The petiole is attached to the Resonant Recorder (fig. 47).

EXPERIMENTAL ADVANTAGES OF CUT SPECIMEN

In this way a fairly large number of specimens can be obtained from the same plant, thus removing the difficulty of scarcity of experimental material. The petiole-pulvinus preparation, moreover, offers greater facilities for experiment. Owing to its small size it can be easily manipulated ; it can be enclosed in a small chamber and subjected to varying conditions of temperature, and to the action of different vapours and gases. Various drugs and chemical solutions can be successively applied at the cut end of the stem without any disturbance of the continuity of the record. Many experiments which would be impossible with the entire plant are in fact quite practicable with the petiole-pulvinus preparation.

For experiments of short duration the experimental preparations can be made still more compact by discarding

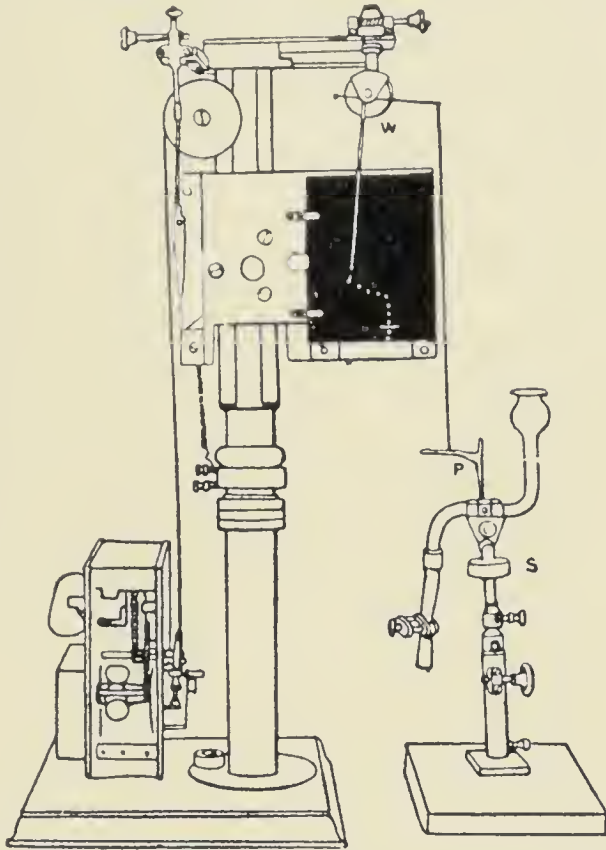

FIG. 47. The petiole-pulvinus preparation attached to the Resonant Recorder.

the U-tube, and tying a piece of moist cloth over the lower end of the stem. Under natural conditions the stem is fixed, and it is the petiole which moves under excitation. But a very interesting case presents itself when the petiole is fixed and the stem free. Here is presented the unusual spectacle of the piece of stem 'wagging' in response to excitation.

The petiole-pulvinus preparation made in this way is often found to have lost its sensibility. This loss I was able to trace to two different factors. First, to the water-logged condition of the pulvinus by excessive absorption of water. The plant, however, gradually accommodates itself to the changed condition, the normal turgor and excitability being restored in the course of one or two hours. Secondly, the severe injury caused by the cutting of the stem induces a temporary loss of excitability. I will presently speak of the condition under which the normal excitability can be restored.

An important factor for experimental success is the choice of a suitable leaf, for both excitability and conductivity are modified by age, as explained below.

MOTO-EXCITABILITY AND CONDUCTIVITY

Much confusion has arisen from the wrong supposition that conductivity and moto-excitability are closely associated with each other in *Mimosa*. The mechanisms are, actually, quite distinct ; I have shown elsewhere¹ that the conducting nervous tissue passes inwards from the petiole *via* the pulvinus into the stem. Owing to this particular distribution of the conducting tissue, a strong stimulus applied to one of the sub-petioles gives rise to a centripetal impulse which, under normal conditions, produces excitatory contraction of the pulvinus of its own leaf and causes the subsequent fall of other leaves, above and below, on the stem. Conversely, a strong stimulus applied on the stem below one of the

¹ *Nervous Mechanism of Plants* (1926).

leaves gives rise to a centrifugal impulse which produces the contractile fall of the nearest leaf, and the subsequent closure of the leaflets of the four attached sub-petioles. Now it is more or less an accident that the motor tissue of the pulvinus should surround the conducting nervous tissue for an insignificant part of its length. If a particular agent paralyses the moto-excitability, it does not necessarily follow that the nerve in the interior has also become paralysed. Though excessive absorption of water causes a temporary abolition of the moto-excitability, it does not affect the conductivity to any appreciable extent. This important fact is clearly established by the results of the following experiments :

Experiment 42.—The pulvinus of an intermediate leaf was rendered immotile by excessive absorption of water. Strong stimulation was applied on one of its four sub-petioles. The impulse was transmitted through the pulvinus to the stem without causing a contractile fall of the leaf. The centripetal impulse, however, reached the other leaves on the stem, both above and below, and caused their fall.

This is analogous to the transmission of a wave of excitation through voluntary muscle-fibre in a state of water-rigor, the transmitted excitation causing contraction in the normal portion of the muscle.

Experiment 43.—A centrifugal impulse was generated by the application of stimulus to the stem 5 mm. below the water-logged pulvinus. The impulse traversed the length of the pulvinus and the petiole without causing the fall of the leaf. All the leaflets of the four attached sub-petioles, however, underwent excitatory closure in serial succession.

The fact that the conductivity of the nerve is independent of the moto-excitability of the pulvinus is also demonstrated by experiment with a stem carrying very old leaves below and young leaves above. The motility of the pulvinus of very old leaves near the base of the stem is permanently abolished on account of old age. But when a strong stimulus is applied to the petiole of one of these leaves, the excitation is

nevertheless transmitted across its own immotile pulvinus and causes the fall of the younger leaves higher up the stem.

EFFECT OF AGE ON CONDUCTIVITY

In a *Mimosa* plant there are leaves of different ages. Of these the youngest are at the top; lower down come the fully grown young leaves, and further down, leaves which are older. I find that the fully grown young leaves are relatively the most excitable. The following experiment deals with the relation of the age of the leaf to the conducting power of the petiole.

Experiment 44. *Comparison of conducting power in different leaves.*—The electric connexions are so made that the same tetanising shock passes through short lengths of very young, fully grown, and older petioles on a shoot of *Mimosa*. As the secondary coil was gradually pushed in, the fully grown young leaf was the first to respond to the induction shock; the secondary coil had to be pushed nearer to the primary by 6 cm. before excitation was effectively transmitted through the very young petiole. For the old leaf a still stronger stimulation was necessary; the secondary had to be pushed through an additional distance of 4 cm. for effective transmission of excitation. I also determined the relative values of the minimal intensity of stimulus effective in the three cases. Adopting, as before, the intensity of electric stimulus which causes bare perception in a human being as the unit, I found that the effective stimulus for a fully grown young petiole was 0.3 unit, while the very young one required 2.5 units, and the moderately old petiole 5 units. Hence it may be said that the conducting powers of fully grown, of very young, and of moderately old petioles are as 16:2:1. In very young specimens the conducting power is but feeble, becoming fully developed later. In old specimens the diminished conducting power is due to permanent physiological decline.

MOTO-EXCITABILITY OF YOUNG AND OLD LEAVES

Experiment 45.—By the employment of constant current in excitation (see Chapter IX) I was able to determine the different excitabilities of very young, fully grown, and older leaves. The very young leaf at the top of the stem required a current of about 6 micro-amperes for effective excitation. The fully grown young leaf lower down was found to be more sensitive, a feebler current of 4 micro-amperes being effective in excitation. The older leaves below required a far stronger current for inducing excitation. The most sensitive leaf was thus the second or the third from the top. A piece of stem bearing such a fully grown young leaf is found most suitable for purposes of experiment.

EFFECT OF WOUND IN MODIFYING EXCITABILITY

I now return to the temporary abolition of excitability after cutting the piece of shoot. It is to be borne in mind that after each excitation the plant becomes temporarily irresponsive, and that the excitability becomes fully restored only after the completion of protoplasmic recovery. A cut or a section acts as a very intense stimulus from the effect of which the recovery is comparatively slow. If the stem be cut very near the leaf, the excitation of the pulvinus is intense, and the consequent loss of excitability becomes more or less persistent. But if the stem be cut at a greater distance, the transmitted excitation is less intense, and the cut specimen recovers its excitability within a reasonable time. I have also succeeded in reducing the depression due to the intense wound-stimulus by previously benumbing the tissue by application of cold.

QUANTITATIVE DETERMINATION OF THE RATE OF
DECAY OF EXCITABILITY AFTER SECTION

Experiment 46. *Variation of excitability after section.*—In order to follow the history of the changes of excitability which are the immediate and after effects of cutting off the

piece of stem, I took an intact plant and fixed the upper half of the stem in a clamp and connected the indicating leaf with the Resonant Recorder. The response of the leaf to direct stimulation by an induction shock of intensity 0.1 unit was now taken; the specimen was vigorous and the response obtained was found to be at its maximum. The stem bearing the leaf was then cut below the clamp at the moment marked in the record with a cross, and water was applied at the cut end. The effect of section was to cause the



FIG. 48. The effect of wound on moto-excitability.

First response normal. x shows contractile fall of the leaf after wound. The subsequent responses exhibit gradual recovery in staircase manner (*Mimosa*).

maximum fall of the leaf, with subsequent recovery. Successive responses to test-stimulations taken afterwards at intervals of 15 minutes showed that depression of excitability had been induced owing to the shock caused by section, and that the excitability became restored in a staircase manner in the course of an hour and a half (fig. 48). This was the case with a vigorous specimen, but with less vigorous ones a longer period of about 3 hours was

required for more or less complete restoration of excitability.

I give a record of the variation of excitability as shown by the leaf of another cut shoot (fig. 49): (*a*) is the record of response to the testing stimulus 4 hours after section. The excitability, under constant external conditions, remained fairly constant for about 12 hours. A steady but slow decline of excitability (*b*) then occurred for the next 12 hours. On the second day the fall of excitability was very rapid (*c*), reaching zero in about 50 hours after isolation. The whole cycle of change may be described as follows: the isolated preparation is rendered insensitive by the shock of section for nearly an hour; the excitability is then gradually restored

almost to its normal value before operation. Under constant external conditions the excitability of the isolated specimen remains fairly constant for about 12 hours, after which depression slowly sets in. The rate of fall of excitability becomes rapid 40 hours after the operation, being finally abolished after the fiftieth hour. It is probable that the rate of fall of excitability in a colder climate would be much slower.

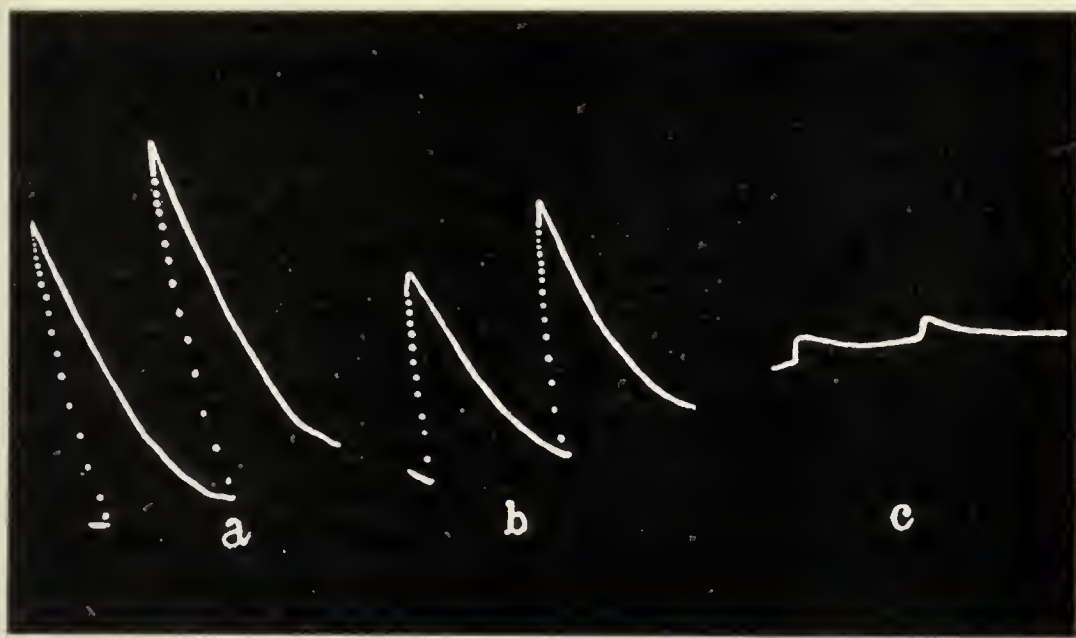

FIG. 49. The effect of wound on detached shoot.

- (a) Vigorous response of leaf of the isolated shoot 4 hours after section; (b) depression after 24 hours, and (c) marked depression after 48 hours, culminating in total abolition of response and death (*Mimosa*).

It may be said in anticipation that the effects of variation of external conditions on the isolated petiole-pulvinus preparation are identical with those manifested in the intact plant. I describe additional experiments which are greatly facilitated by the more easily managed cut specimens. For instance, the condition of subtonicity is more easily induced in isolated specimens, and greater facility is offered for studying the effect of external stimulation in raising the tonic level of the specimen. In regard to the action of various chemical solutions, the particular drug can be applied at the cut end of the stem.

ACTION OF LIGHT AND DARKNESS ON EXCITABILITY

The marked change in excitability in an intact plant under variation of light has already been described (*see* fig. 38, p. 69). It was shown that a slight darkening due to the passage of a cloud caused immediate depression, while the

disappearance of the cloud was followed by an equally quick restoration of excitability.

In order to ascertain whether or not this effect of light is connected with photosynthetic action, I took a petiole-pulvinus preparation from which the sub-petioles bearing the photosynthetic leaflets had been cut off; the specimen was placed in a room illuminated by diffuse daylight.

Experiment 47.—The normal responses were taken under diffuse light, the temperature of the room being 30° C. The room was then darkened by pulling down the blinds, and



FIG. 50. Stimulating action of light, and depressing action of darkness.

Horizontal line below represents period of darkness.

the record was continued in darkness, the temperature of the room remaining unchanged at 30°. The record (fig. 50) shows that a great depression of excitability had occurred in darkness. The blinds were then pulled up, and the restoration of the normal amplitude of response demonstrates the stimulating action of light. The results establish the fact that light has a direct tonic action quite apart from photosynthesis. This finds independent support from the fact, which will be demonstrated later, that the enhancement of

excitability is induced in a subtonic tissue not merely by photic stimulation but also by electric stimulation.

ACTION OF BARIUM CHLORIDE

Experiment 48.—The action of barium chloride on the contractile response of muscle is a prolongation of the period of recovery, and a characteristic double contraction. The sluggishness in recovery and the double contraction disappear in a short time after repeated stimulation by tetanising electric shocks. The effect of the reagent on the response of the pulvinus is very similar. After the application of 1 per cent. solution BaCl_2 , the response exhibited a double contraction and incomplete recovery (fig. 51). The sluggishness induced was so great that the next stimulation, represented by a thick dot, was ineffective. The pulvinus was now subjected for a short time to tetanising electric shocks, the response to which was not recorded. The after-effect of tetanisation was the removal of sluggishness, as shown in the next three records, which were taken under the original testing stimulus. The response is now a single contraction followed by complete recovery.



FIG. 51. Incomplete recovery under the action of BaCl_2 and transient restoration under tetanisation at τ (*Mimosa*).

ANTAGONISTIC ACTION OF ACID AND ALKALI

Acid and alkali are known to exert antagonistic actions on the spontaneous beat of the animal heart.

Experiment 49.—It is very interesting to find that these

agents also produce their antagonistic effects on the contractile response of *Mimosa*. This is illustrated in fig. 52, where the application of 1 per cent. solution of lactic acid arrested the response in contraction; the antagonistic action of dilute NaOH is shown in the restoration of excitability; its continuous application, however, caused a second arrest, but this time in a state of relaxation.

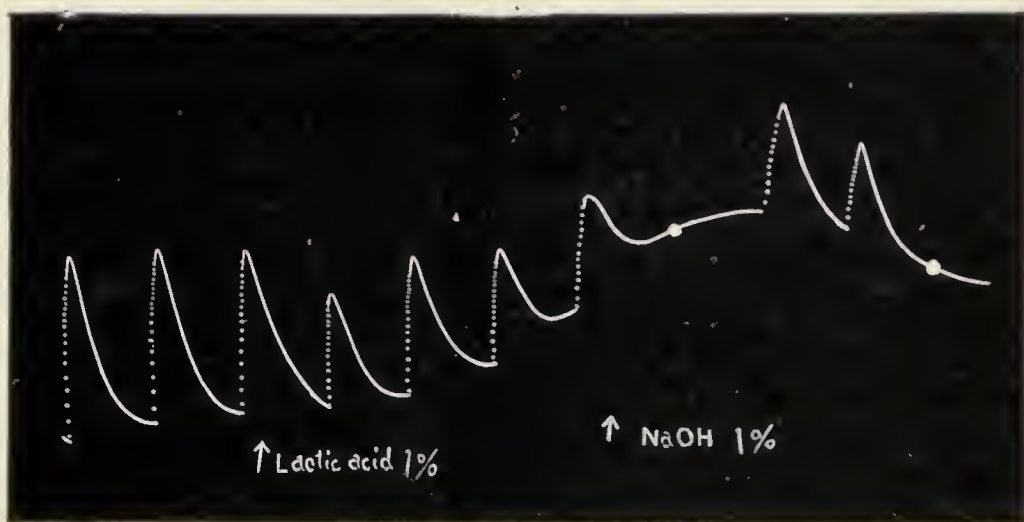

FIG. 52. Antagonistic action of acid and alkali.

Arrest of response in contraction under lactic acid; restoration and final arrest in expansion under NaOH (*Mimosa*).

The most important outcome of the results described is that all the investigations on the irritability of the intact *Mimosa* plant can be successfully repeated with the petiole-pulvinus preparation. The difficulty arising from the supply of material has thus been entirely removed. Several experiments, practically impossible with the intact plant, can be successfully carried out with the isolated preparation, which allows far greater facility for manipulation.

SUMMARY

For investigations on irritability, the isolated petiole-pulvinus preparation of *Mimosa* can be substituted for the intact plant.

It is shown that in *Mimosa* conductivity is independent of moto-excitability. The pulvinus may have been rendered immotile, yet the excitatory impulse is transmitted along the enclosed nervous tissue in both centripetal and centrifugal directions, causing the fall of other leaves on the stem and the closure of leaflets on the sub-petioles.

The age of the leaf has influence on its conductivity and moto-excitability which attain their maxima in the fully grown young leaf. The conducting power of a fully grown young leaf is eight times that of a very young leaf, and sixteen times that of a moderately old leaf.

The effect of a severe wound is to cause intense excitation, the after-effect of which is a depression of excitability. Excitability is, however, gradually restored in a staircase manner.

After recovery from the effects of section of the stem, the excitability of the isolated preparation remains uniform for nearly 12 hours, during which experimental investigations can be carried on with greater facility than with an intact plant. There is a gradual fall of excitability from the twelfth to the twenty-fourth hour. The depression becomes rapid 40 hours after isolation, excitability being abolished after the fiftieth hour.

CHAPTER VIII

THE DIURNAL VARIATION OF MOTO-EXCITABILITY IN MIMOSA

SEVERAL instances of daily periodicity are known, but the relations between the recurrent external changes and the resulting periodic variations are more or less obscure. The complexity of the problem is great, for not only have the effects of changing environment to be taken into account, but also their unknown after-effects. Different factors again, such as light, temperature, turgor, etc., are undergoing independent variation, and the physiological changes induced by them are either concordant or antagonistic. Among the instances of diurnal periodicity may be mentioned the nyctitropic movements of plants. The fanciful name of 'sleep' is commonly given to the closure of the leaflets of certain plants at night. Whether plants really sleep or not can only be ascertained by a definite inquiry as to whether or not the plant is equally excitable throughout the day and night. If it is not, then is there any definite period during which it practically loses its sensibility? Is there, again, another period at which the plant wakes up, as it were, to a condition of maximum excitability?

The diurnal variation of the excitability of *Mimosa* was experimentally investigated by subjecting the plant at every hour of the day and night to a test-stimulus of uniform intensity, and obtaining the record of the resulting mechanical response at different periods during 24 hours. Under these circumstances the amplitude of response at any hour

serves as a measure of the excitability of the plant at that particular moment. A periodic fluctuation of response would demonstrate the periodic character of variation of excitability.

The investigation thus resolves into :

- (1) The successful construction of a recorder which will automatically record the response of the plant to uniform periodic stimulation at all hours of the day and night.
- (2) The study of the effects of external changes on excitability ; and
- (3) The discovery of the relation of diurnal variation of excitability to the changes of environment.

THE AUTOMATIC RECORDER FOR TWENTY-FOUR HOURS

I give a diagrammatic view (fig. 53) of the different parts of the apparatus which was devised for this investigation. The leaf of *Mimosa* is attached to one arm of a light aluminium lever L by means of a thread. At right angles to the lever is the writing-index W, which traces the responsive movement of the leaf on a smoked-glass plate, allowed to fall at a definite rate by clockwork. Under a definite stimulus of electric shock, the leaf falls down, and the response is recorded on the plate by the writing-lever.

Successive stimulations of constant intensity are applied at intervals of, say, an hour ; comparison of the responses shows whether the excitability of the plant had remained constant or undergone any variation.

UNIFORM PERIODIC STIMULATION

The leaf was periodically stimulated by tetanising electric shocks of constant and sub-maximal intensity. The exciting value of the tetanising shock depends (1) on the intensity, and (2) on the duration, of the shock. The intensity can be rendered uniform by fixing the secondary at a definite

distance from the primary; the current in the primary circuit is kept constant by the employment of a storage-cell of definite electromotive force. The duration of the induction-shock given by the secondary coil depends on the length of time during which the primary circuit is completed in each stimulation. The completion of the primary circuit

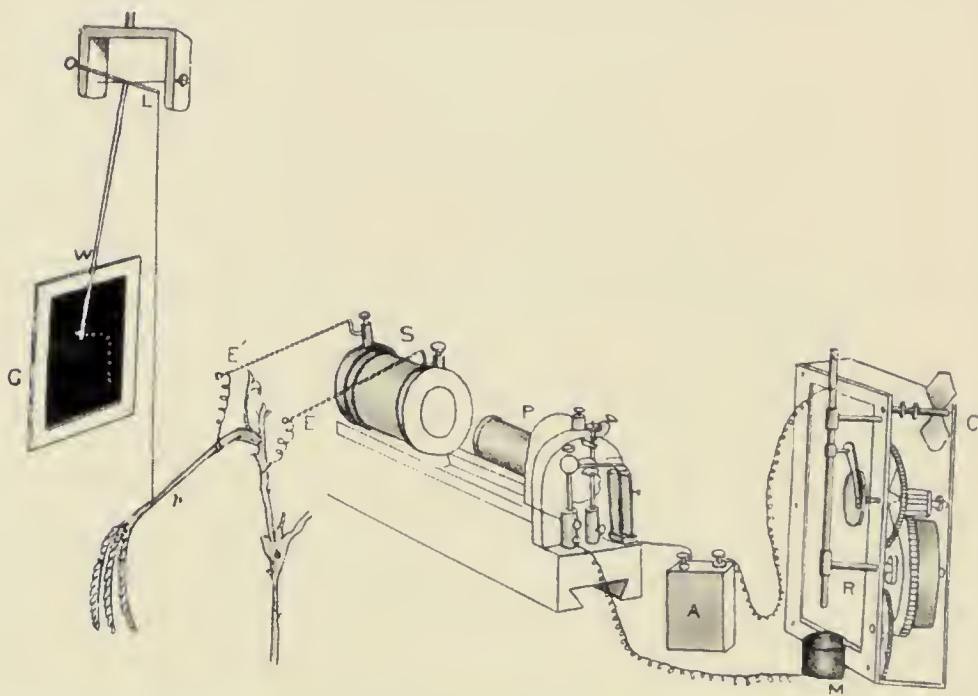

FIG. 53. Diagrammatic representation of the complete apparatus for determination of the diurnal variation of excitability.

Petiole of *Mimosa*, attached by thread to one arm of lever; the writing-index *w* traces on the smoked-glass plate *G* the responsive fall and recovery of leaf. *P* primary, and *S* secondary, of induction-coil. Exciting shock passes through plant by electrodes *E*, *E'*. *C*, clockwork for regulating duration of shock. Primary circuit of coil completed by plunging rod *R*, dipping into cup of mercury *M*.

is made by a plunging rod *R*, which dips into a cup of mercury *M*. The duration of closure of the circuit is adjusted by clock-mechanism (fig. 53); in the following experiments it was 0.2 second.

The clock employed performs three functions. The axis, which revolves once in 12 hours, has attached to it a wheel, round which is wound a thread which allows the recording-glass plate to fall through 6 inches in the course

of 24 hours. A spoke attached to the minute hand releases the alarm at intervals of an hour and actuates the plunging rod R, which then completes the primary circuit of the induction-coil. The plant is thus subjected at specified times to tetanising induction-shocks of uniform intensity and duration. The record of response was taken on an Oscillating Recorder.

EFFECT OF EXTERNAL VARIATIONS ON EXCITABILITY

Before giving the daily records of the hourly variation of excitability, I will give some experimental results which illustrate the effect of external variations in modifying excitability.

Under natural conditions the plant is subjected (1) to periodic variation of light and darkness; (2) to hourly variation of temperature. I will explain how each of these factors modifies the moto-excitability of the plant.

VARIATION OF LIGHT

The plant is subjected to light from morning to evening and to continuous darkness from evening to early morning. The excitability of the plant has been shown to increase under light and to decrease under darkness (*cf.* figs. 38, 50).

VARIATION OF TEMPERATURE

The experiments on periodic variation of moto-excitability were carried out in early spring (February) and in summer (May). The highest temperature was attained at different seasons between 12 noon and 3 P.M. The minimum temperature was reached between 5 and 6 A.M. The maximum and minimum temperatures in spring were 29° C. and 20° C. respectively. The summer maximum was 38° C., about 3° higher than the optimum; the minimum was 25.5° C.

I have shown that the excitability of the plant increases with moderate rise of temperature, the maximum excitability being attained at or about 35° C., which is the optimum.

In order to determine the changes of excitability induced by changes of temperature below and above the optimum, I carried out the following experiments.

Experiment 50. *Effect of moderate lowering of temperature.*—A simple way of exhibiting the effect of lowering of

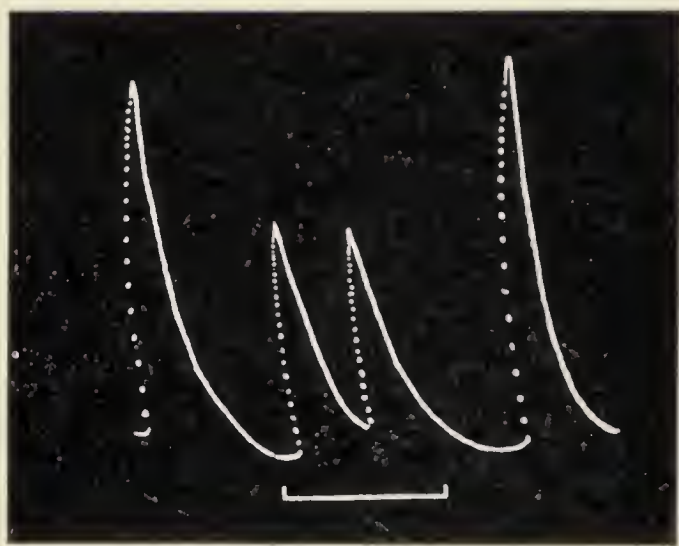

FIG. 54. Effect of moderate cooling in depressing excitability. Duration of application of cold shown by the horizontal line below (Mimosa).

temperature is by the artificial cooling of the pulvinus. This cannot very well be done by the application of a stream of cooled water, since absorption of excess of water by the pulvinus is attended by a loss of excitability; dilute solution of glycerine has, however, no such drawback. This liquid at ordinary temperature was first applied on the pulvinus, and record was taken in the usual manner. Cooled liquid was then applied and record taken once more (fig. 54). The first or normal response was taken at the temperature of the room, which was 32° C.; the next two exhibit depression of excitability under moderate cooling, the duration

of which is indicated by the horizontal line below. After this the plant regained the normal temperature of the room, with the restoration of normal excitability.

Experiment 51. *Effect of excessive cooling.*—The record (fig. 55) shows the effect of cooling by ice-cold glycerine solution. The immediate effect was depression, followed by complete abolition of excitability. Thick dots in the record represent applications of stimulus which proved

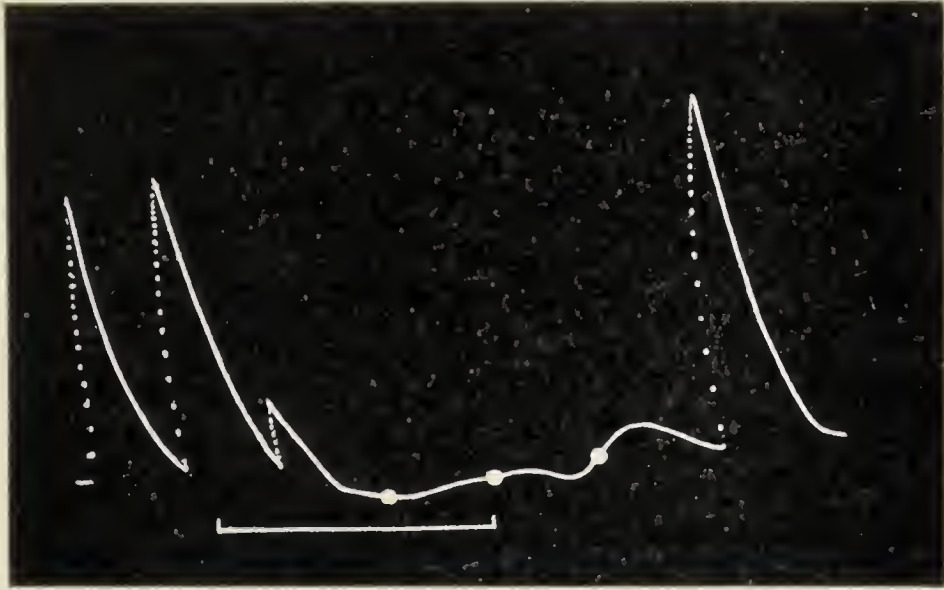

FIG. 55. Effect of exposure to intense cold.

Note sudden depression followed by abolition of excitability, also persistent after-effect (Mimosa).

ineffective. It will also be noted that even after the cessation of cooling and the return to normal temperature the induced abolition of excitability persisted as an after-effect for a considerable length of time. The results prove that, on account of physiological inertia, *the variation of excitability persists beyond the external change which induced it.*

Experiment 52. *Effect of high temperature.*—The moto-excitability undergoes depression at any temperature above the optimum. This is seen in the following record (fig. 56), where the normal response at 32° C. was depressed by gradual rise of the temperature of the plant-chamber to

42° C. ; the excitability was slowly restored when the plant was allowed to regain the former temperature.

I briefly recapitulate some of the important results : Light enhances the moto-excitability, while prolonged darkness depresses it. Far more marked is the effect of temperature : lowering of temperature depresses and

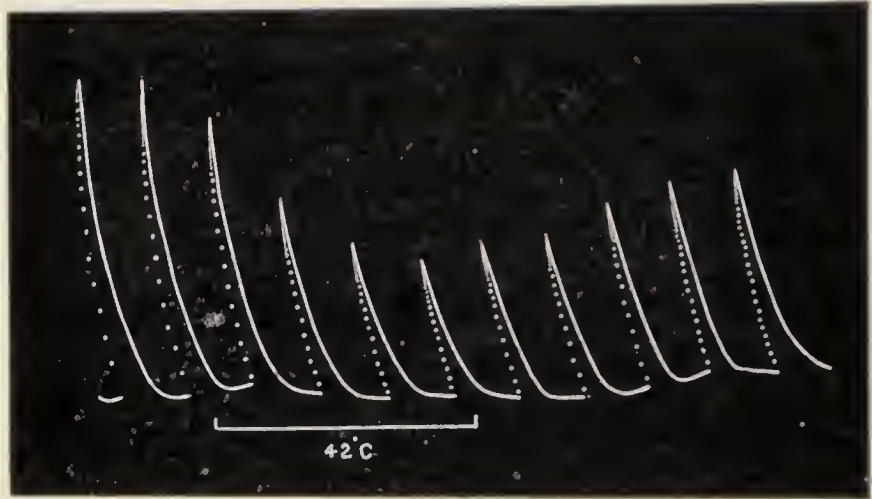

FIG. 56. Effect of temperature above optimum. Note depression of excitability induced by high temperature, and gradual restoration on return to normal (Mimosa).

finally abolishes the moto-excitability ; rise of temperature enhances it up to an optimum temperature, above which the excitability undergoes a decline. The change of excitability induced by variation of external conditions is not immediate, but lags behind the inducing cause ; the after-effect also persists for a time.

DIURNAL VARIATION OF EXCITABILITY

The automatic record of the responses under uniform testing stimulus every hour exhibits the characteristics of the diurnal variation of moto-excitability.

Experiment 53.—As a typical example I reproduce a record (fig. 57) obtained in spring in the month of February. The record was commenced at 5 P.M., and continued to the same hour next day, the plant being stimulated once every hour.

Examination of the characteristic variations of response throughout the 24 hours shows that a continuous decline occurred after the setting in of darkness at 7 P.M. The

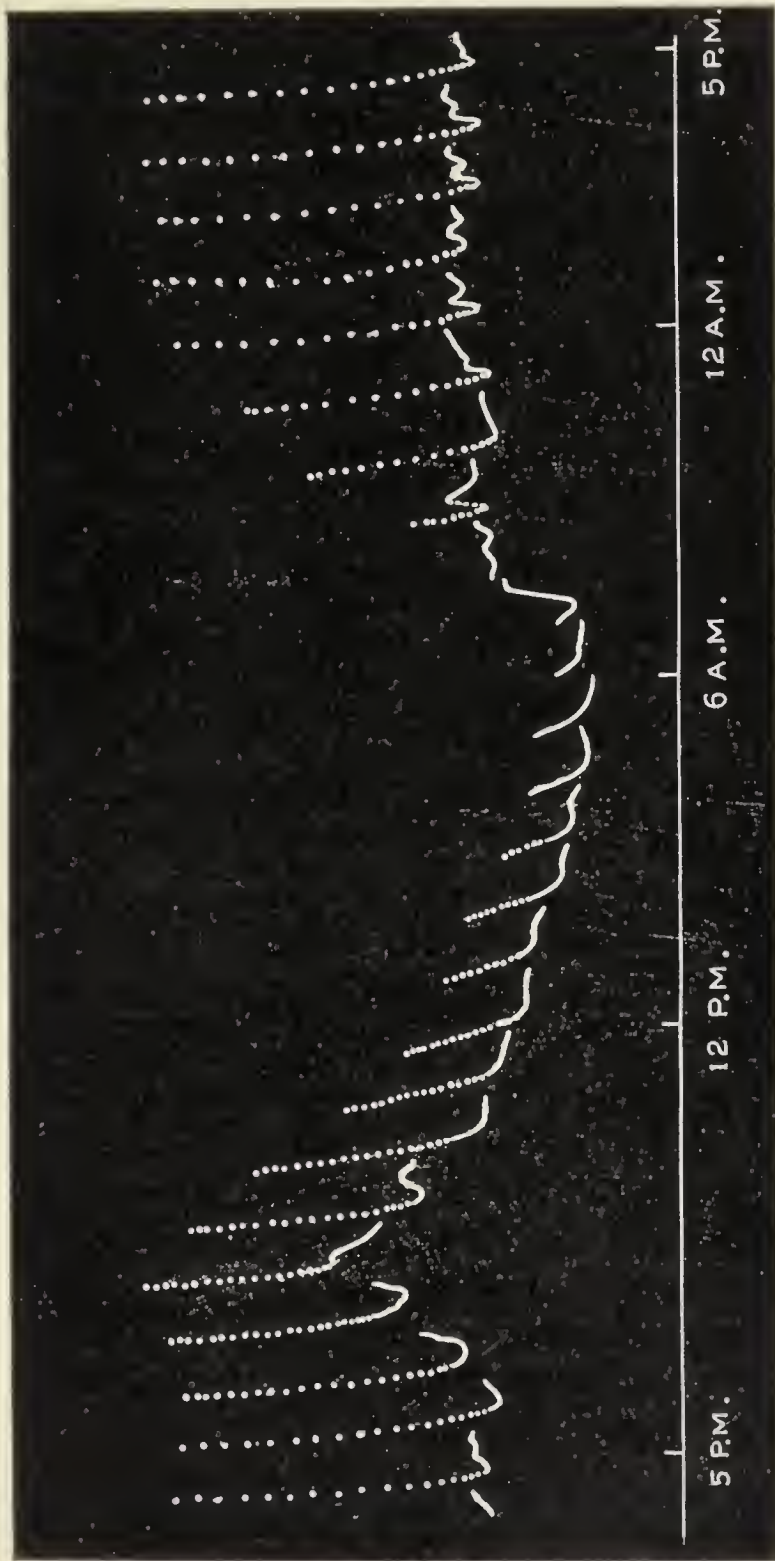

FIG. 57. Record for 24 hours, exhibiting diurnal variation of excitability (spring-specimen). The displacement of the base-line is due to nyctitropic movement. Fall of leaf represented by up-curve, erection by down-curve. Hours of darkness, 7 P.M. to 5 A.M. The sun rose at 6 A.M.

fall of excitability continued even after sunrise, at about 6 A.M., and the response was practically abolished between 8 and 9 A.M. The excitability then gradually increased in a staircase manner, the maximum being reached after 12 noon; the excitability after this hour remained more or less constant till late in the afternoon. It will be noted that the amplitude of the response at 5 P.M. on the second day was the same as that of the corresponding response on the previous day.

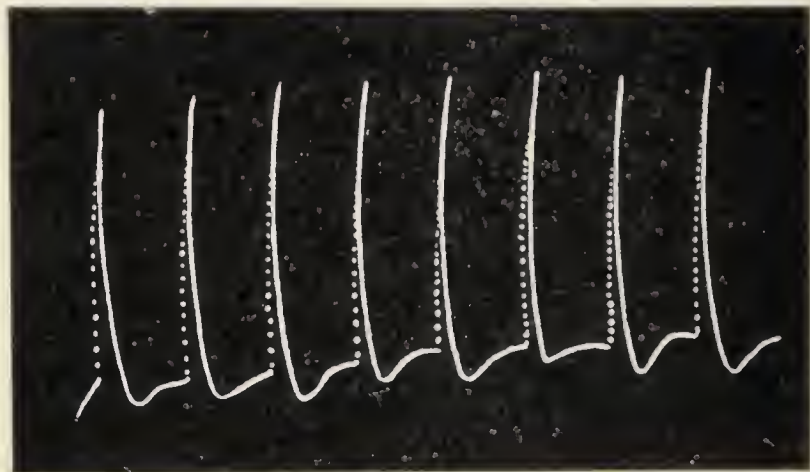

FIG. 58. Midday record from noon to 3 P.M., exhibiting uniform and maximum excitability.

Record of response to stimulation taken every half an hour.

The results of numerous records taken in spring may be summarised as follows :

- (1) The maximum excitability of *Mimosa* is attained at or about noon, and remains constant for several hours. I give a series of records taken every half an hour on a fast moving plate (fig. 58) in which the uniformity of responses demonstrates constancy of excitability during the period.

In studying the influence of external variations on excitability, it is best to carry out the experiments during the midday period, for the observed change will then be due to the external agent and not to variation in the plant.

- (2) Excitability undergoes a continuous decline from evening to morning, the response being practically abolished between 8 and 9 A.M.

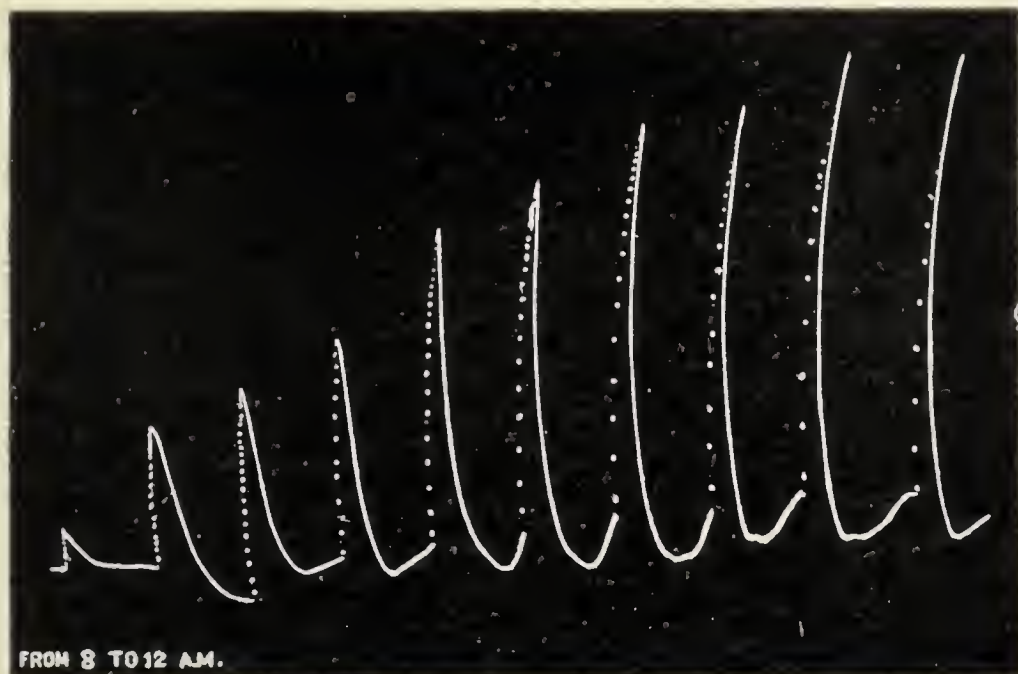

FIG. 59. The gradual waking up of the plant from 8 A.M. to 12 noon.
Record every half an hour.

- (3) After 8 A.M. the excitability is gradually increased in a staircase manner till the maximum is reached at noon ; records taken once every half an hour on a faster moving plate show this in a very clear manner (fig. 59).

VARIATION OF TURGOR

It will be observed in the record (fig. 57) that the level of the base-line varies. This is due to rising and sinking of the leaf itself, which, in turn, is caused by changes in the turgor of the pulvinus ; hence the variations in level of the base-line represent and record variations of turgor. The changes in the external conditions affected not only the moto-excitability of the leaf, but the turgor of its pulvinus as well ; but inversely, maximum moto-excitability coinciding

with minimum turgor, and *vice versa*. This is in accordance with a previous observation (*cf.* p. 70) that the motility of the leaf is diminished when turgor becomes too high. The highest erection of the leaf, indicative of maximum turgor, was reached at 6 A.M. : the leaf then fell slowly and reached the middle position at noon, when the turgor-condition was neither too high nor too low. On account of the sudden change of light to darkness, an excitatory fall of the leaf (with diminution of turgor) occurred after 6 P.M., as shown by the displacement of base-line upwards. A continuous increase of turgor was recorded after 9 P.M., with displacement of the base-line downwards, the maximum turgor being attained, as already stated, at 6 A.M.

The causal relation between change in the external conditions and the variation of excitability may now be discussed. It has been shown that moto-excitability is greatly influenced by temperature. In order to find in what manner the diurnal variation of excitability is influenced by the hourly variation of temperature, I took special care to secure, by means of the thermograph, a continuous record of the temperature-variations. The following table shows the relation between the hours of the day, the temperature, and the excitability measured by the amplitude of response.

TABLE V.—SHOWING THE RELATION BETWEEN HOURS OF THE DAY, TEMPERATURE, AND THE AMPLITUDE OF RESPONSE (SPRING-SPECIMEN).

Hours of day	Temperature	Amplitude of Response	Hours of day	Temperature	Amplitude of response
5 p.m.	28.0° C.	28.0 mm.	5 a.m.	20.0° C.	5.0 mm.
6 "	25.5° "	28.0 "	6 "	20.5° "	4.2 "
7 "	24.5° "	27.0 "	7 "	21.0° "	3.5 "
8 "	23.0° "	23.5 "	8 "	22.0° "	2.5 "
9 "	22.0° "	21.5 "	9 "	24.0° "	0.0 "
10 "	21.0° "	18.0 "	10 "	26.0° "	6.0 "
11 "	20.5° "	15.0 "	11 "	26.5° "	15.5 "
12 "	20.0° "	13.0 "	12 "	28.0° "	22.5 "
1 a.m.	20.0° "	10.0 "	1 p.m.	28.0° "	26.0 "
2 "	20.0° "	8.0 "	2 "	28.5° "	28.0 "
3 "	20.0° "	7.5 "	3 "	28.5° "	28.0 "
4 "	19.5° "	6.0 "	4 "	29.0° "	28.0 "

In fig. 60 are shown two curves, (1) of variation of temperature and (2) of variation of excitability, during the 24 hours. The data for these were obtained from records taken on a day later in spring when the maximum temperature was 33° C. and the minimum 22° C. The striking resemblance between the two curves demonstrates

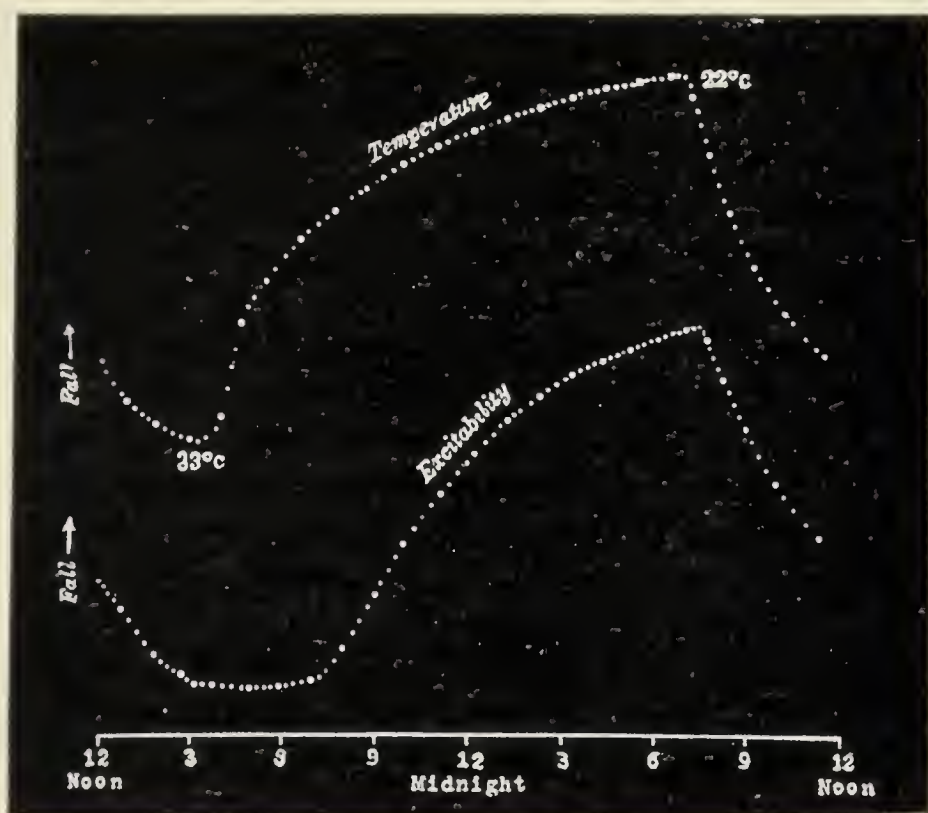

FIG. 60. Curve of variation of moto-excitability of *Mimosa pudica*.

The upper curve gives the variation of temperature and the lower the corresponding variation of excitability.

the predominant influence of temperature on the diurnal variation of excitability.

Effect of physiological inertia.—The experimental results already described showed that the change of excitability lags behind the inducing cause. This is further illustrated by the diurnal curve (*cf.* fig. 57); the minimum temperature was attained shortly after 5 A.M., but excitability was not reduced to a minimum till about 3 hours later.

I will now discuss in greater detail the diurnal variation of excitability in *Mimosa*, taking the typical case illustrated in fig. 57. The favourable temperature was here almost constant from noon to 5 P.M.; the condition of light was also favourable. Hence the excitability was found to be constant and at its maximum between these hours. The temperature began to fall after 6 P.M., and there was, in addition, the depressing effect of gathering darkness. Owing to the time-lag, the fall of excitability did not commence immediately at 6 P.M., but an hour afterwards, and continued till the next morning. During this period there was cumulative effect not only of darkness but also of depression caused by the falling temperature. The turgor was also at its maximum early in the morning, which tends to produce depression of moto-excitability. On account of the combined effects of these different factors, and of the phenomenon of lag, the period of minimum excitability was reached at about 8 A.M. The excitability was then gradually and continuously increased under the continued action of light and of rising temperature, till the maximum was attained shortly after noon.

EFFECT OF SEASON

As has been shown, temperature exerts a predominant influence in inducing variation of excitability. The diurnal period is, therefore, characteristically modified according to the season. In winter and in early spring the night temperature falls very low, resulting in a complete abolition of excitability, which persists for a considerable period in the morning. In summer the prevailing high temperature causes a characteristic modification. As the night is warm the fall of excitability is not so great as in spring. The minimum temperature early in the morning in summer is 25.5° C., instead of 19.5° C. in spring. Hence the excitability in the morning exhibits depression but not total abolition. After the minimum in the morning the excitability is restored in a staircase manner as in spring.

During daytime, again, the temperature often rises to 38°C . between 1 and 3 P.M., after which there is a mitigation of heat, the temperature returning towards the optimum.

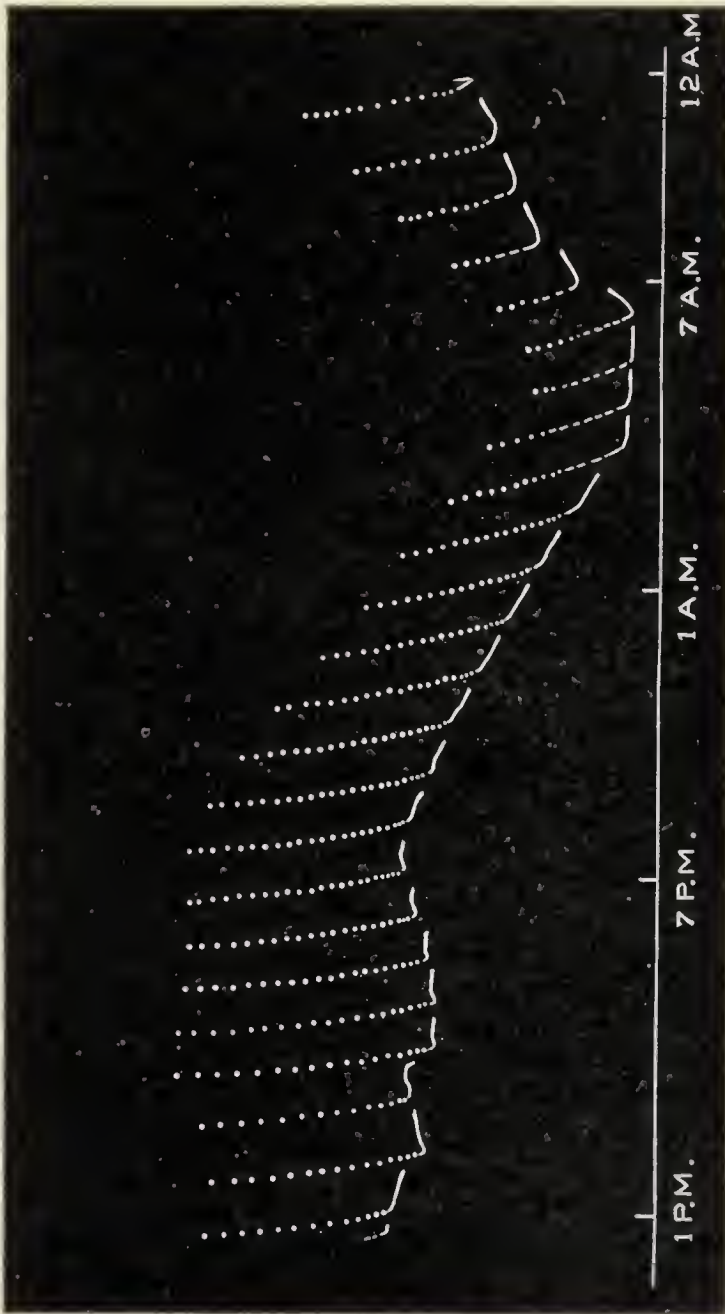

FIG. 61. Diurnal variation of moto-excitability exhibited by summer-specimen (*Mimosa*).

The record (fig. 61) shows the excitability to have been higher between 4 and 6 P.M. than between 1 and 3 P.M.

Experiment 54.—An interesting variation is seen in the following record, obtained in summer, in which the nyctitropic

104 CHAP. VIII. DIURNAL VARIATION OF MOTO-EXCITABILITY
movement was very pronounced. The periodic variation
of excitability exhibited here is practically the same as that

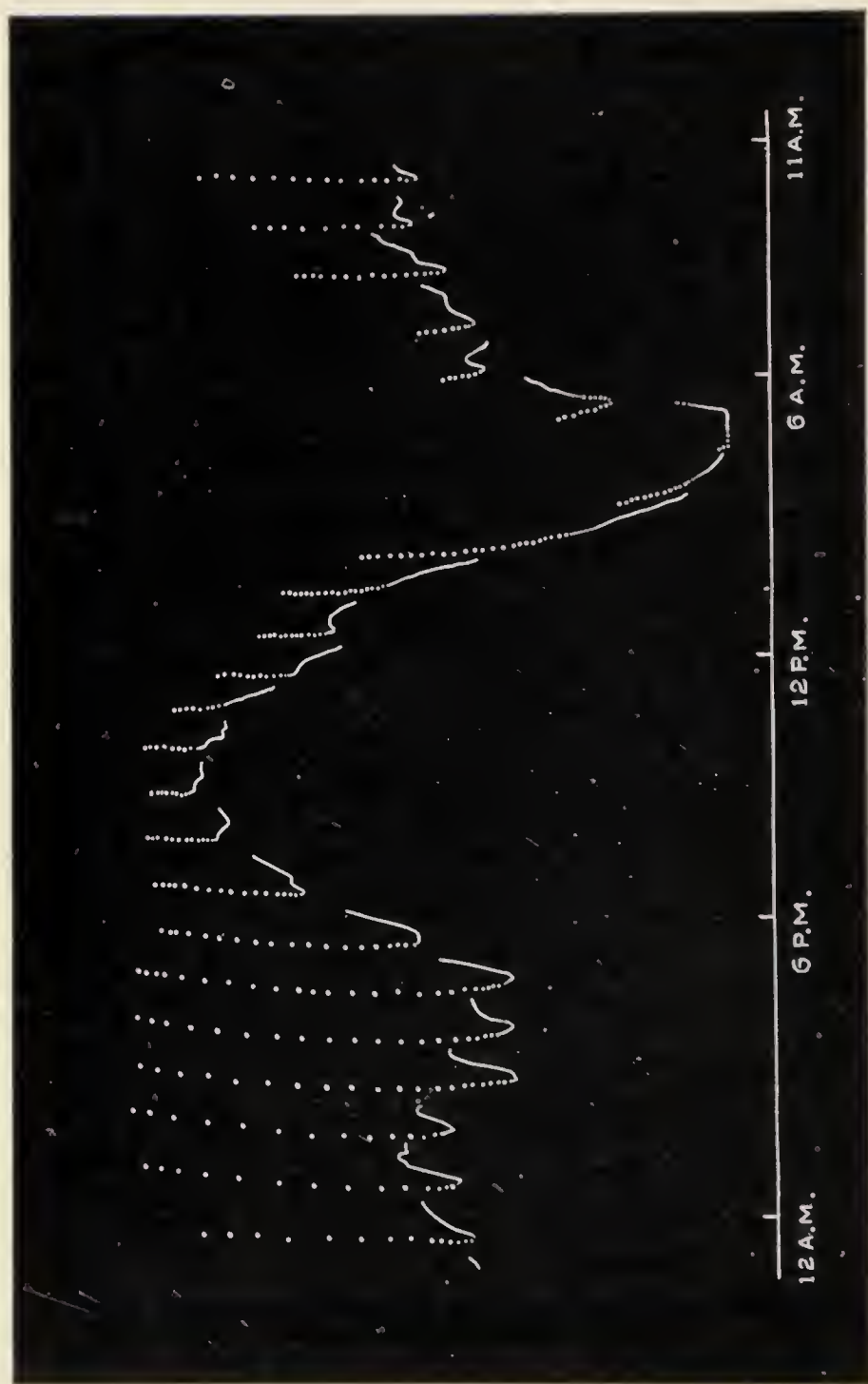

FIG. 62. Record of diurnal variation of excitability of specimen which exhibited marked nyctitropic movement (*Mimosa*).

in other summer-specimens (*cf.* fig. 61). The interesting variations, noticeable after 5 and 9 P.M., are the charac-

teristic differences in the curve of recovery. On account of the rapid diminution of light there was a sudden excitatory fall of the leaf, exhibited by the displacement of the base-line upwards, which persisted till 9 P.M. On this account the recovery after each stimulation appears to be incomplete. The extent of the responsive fall is also seen to have reached a limit, for the leaf cannot fall beyond the maximum. After 9 P.M. there was a rapid increase of turgor, which reached its maximum about 6 A.M., causing a rapid erectile movement of the leaf, shown by the down-movement of the base-line. After each stimulation there now appeared an overshooting of the line of recovery (fig. 62).

SUMMARY

The moto-excitability of *Mimosa* was gauged every hour of the day and night by the amplitude of the response to a constant testing stimulus. This was effected by means of automatic devices for periodic stimulation and for recording the resulting responses.

The diurnal record shows that the excitability of the plant is not the same throughout the day, but undergoes characteristic variation at different hours. In a typical case in spring the excitability attained its maximum value after midday and remained constant for several hours. There was then a continuous fall of excitability, the minimum being reached at about 8 in the morning. The plant was at this time practically insensitive. The moto-excitability was then gradually restored in a staircase manner till it again reached its maximum at 12 noon.

The diurnal variation of excitability is primarily due to the hourly variation of temperature. The effect is modified in a less degree by the variation of light.

CHAPTER IX

EXCITATION BY POLAR ACTION OF CONSTANT ELECTRIC CURRENT

It was stated in a previous chapter that stimulation of the plant can be effected by the application of a constant electric current. A feeble current has the unique advantage of producing local stimulation; this is a matter of great importance in certain investigations of a crucial character, such as one described in a subsequent chapter.

It is well known that an electric current causes specific excitatory reactions in animal tissues. Excitation is characteristically produced at the sudden starting or 'make' of the current; it may also be produced at the stoppage or 'break' of the current. Thus when a feeble current is passed by means of two electrodes through a muscle, an excitatory contraction is initiated on the sudden starting of the current at the kathode where the current leaves the tissue, no excitation being produced at the anode, that is at the point of entrance of the current. At the break of the current, excitation is produced neither at the kathode nor at the anode. When the intensity of the electric current is increased the excitation due to the make still takes place at the kathode only; whereas at the break of the current excitation takes place at the anode.

The characteristic polar effects of current on Protozoa have been found by different observers to be, generally speaking, opposite to those on animal tissues. Hence it has been supposed that the laws of polar reaction in unfibrillated protoplasm must be different from those in highly

differentiated animal tissues. My experiments on the polar action of electric current on plants prove, on the contrary, that the reactions of the undifferentiated protoplasm of the plant-body are identical with those of the animal tissues. This is demonstrated by the following experiments with the primary pulvinus of *Mimosa pudica*.

POLAR ACTION OF CURRENT ON PULVINUS OF MIMOSA.
MONOPOLAR METHOD

One electrode from a battery is applied on the pulvinus, and the second electrode attached to a distant indifferent

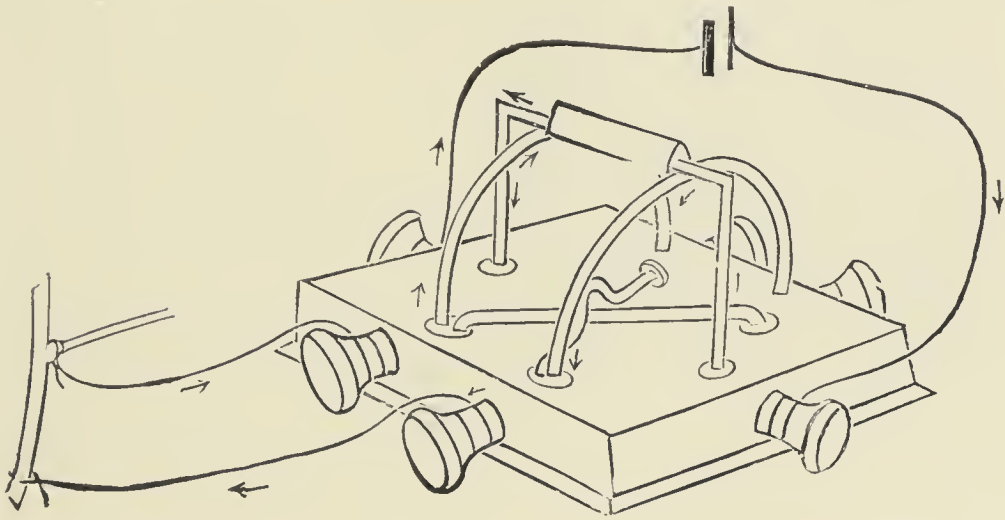

FIG. 63. Commutator, for causing make and break of the current, and changing its direction.

point. Four cycles of operation can be performed with the commutator by which the current in either direction can be made or broken. Fig. 63 illustrates the position after sudden make of the current by tilting the commutator to the left, the pulvinus being made the kathode. By proper manipulation of the commutator, the pulvinus may be subjected (1) to kathode-make, (2) to kathode-break, (3) to anode-make, and (4) to anode-break.

Experiment 55. *Effect of feeble current.*—I used a leaf of *Mimosa* which was in a moderately sensitive condition.

The electric resistance between the two points of contact was found to be a million ohms. An E.M.F. of 8 volts was found to be effective in inducing the excitatory fall of the leaf, the pulvinus being made the kathode. Excitation is induced on sudden variation of the current and not during the continuance of it. Hence, if after the excitatory fall the current is continued, the leaf re-erects itself.

Experiment 56. *Effect of moderate current.*—The E.M.F. of the acting current was next increased to 12 volts. In carrying the experiment through the usual cycle of operations,

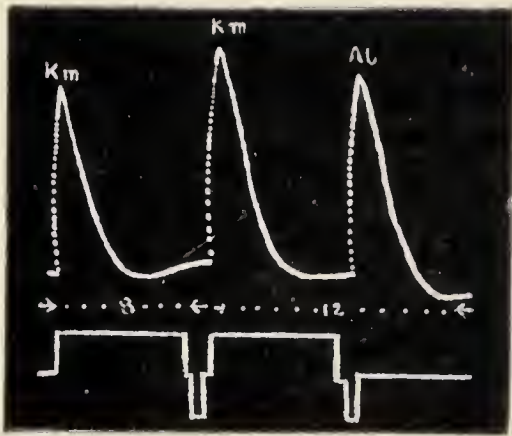

FIG. 64. Response under 8 volts excitation at Km; under 12 volts excitation at Km and at Ab.

it was found that the kathode excited at make and not at break. The effect of the anode, on the other hand, was that it excited at break and not at make.

The automatic record by the plant is given in fig. 64. The normal signal-line below indicates no current; the up-line, kathode-make; return to horizontal, kathode-break;

down-line, anode-make; and return to the horizontal represents anode-break. It will be noted that under 8 volts excitation took place only at kathode-make, represented by the symbol Km. Under 12 volts there is a stronger response at kathode-make and none at kathode-break; no excitation was produced at anode-make, but it occurred at anode-break Ab. The excitation formula under the action of moderate current is therefore KmAb.

The universality of these characteristic polar excitations is proved by the results of experiments which I carried out with the sensitive organs of various other plants, such as the leaflets of *Mimosa*, of *Biophytum*, of *Neptunia oleracea*, of *Averrhoa Carambola* and of *Averrhoa Bilimbi*. The

effective intensity of the current depends on the excitability of the particular specimen, a vigorous specimen being excited by a relatively feeble current. It also depends on the relative excitability of different motor organs, the pulvinules of the leaflets being, in general, more sensitive than the main pulvinus. As an example of the response

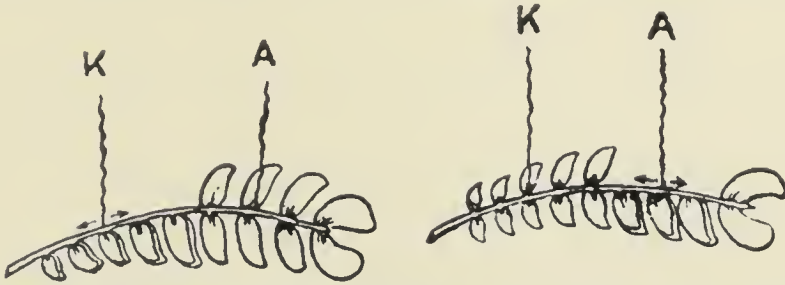

FIG. 65. Illustration to the left shows excitation of leaflets of *Biophytum* induced at kathode-make, that to the right the effect at anode-break; moderate current.

of the leaflets, I describe an experiment with *Biophytum sensitivum*, employing the *Bipolar method*. The two electrodes were applied at two points on the petiole, which carries numerous pairs of motile leaflets.

I give a sketch (fig. 65) showing the application of the bipolar method in excitation of leaflets of *Biophytum*, where K is the kathode and A the anode.

THE BIPOLAR METHOD

Experiment 57. *Effect of feeble current (Biophytum)*.—This caused excitation only at kathode-make and not at break. No excitation was produced at anode on either make or break. The formula for the excitatory reaction is thus Km.

Experiment 58. *Effect of moderate current (Biophytum)*. Excitation took place only at kathode-make and not at anode-break; the figure to the left shows the excitation initiated at the cathodic point at make, which did not remain localised but was conducted in both directions. After the recovery of the leaflets the circuit was broken and excitation was initiated at the point of anode-break (fig. 65). The formula for moderate intensity of current is KmAb.

Numerous experiments were carried out with different plants which give similar results. In the two tables (below) are given the effects of feeble and of moderate current. The value of the current given is what was found to be minimally effective for highly excitable specimens.

The specific reactions of the plants to electric current are thus in every way similar to those in animal tissues.

The Laws of Polar Excitation for Plants are :

(I) WITH FEEBLE CURRENT, THE KATHODE EXCITES AT MAKE AND NOT AT BREAK. THE ANODE EXCITES AT NEITHER MAKE NOR BREAK.

(II) WITH CURRENT OF MODERATE INTENSITY, THE KATHODE EXCITES AT MAKE AND NOT AT BREAK. THE ANODE EXCITES AT BREAK AND NOT AT MAKE.

TABLE VI.—EFFECT OF FEEBLE CURRENT ON VARIOUS SENSITIVE PLANTS.

Specimen	Number of experiments	Minimum current in micro-amperes
Leaflets of Mimosa .	25	0·7
„ Biophytum .	50	0·5
„ Neptunia .	5	7·0
„ A. Carambola .	10	4·0
„ A. Bilimbi .	5	6·0
Leaf of Mimosa . .	15	2·0

Excitation occurs at kathode-make. Formula Km.

TABLE VII.—EFFECT OF MODERATE CURRENT ON VARIOUS SENSITIVE PLANTS.

Specimen	Number of experiments	Minimum current in micro-amperes
Leaflets of Mimosa .	25	1·6
„ Biophytum .	50	2·1
„ Neptunia .	5	12·0
„ A. Carambola .	10	11·0
„ A. Bilimbi .	5	16·0
Leaf of Mimosa . .	15	4·0

Excitation at kathode-make and at anode-break. Formula KmAb.

From the results given above it is seen that under a gradual increase of current the first type of response, K_m , is transformed to the second type K_mAb . Can any further transformation be discovered under still greater intensity of current?

POLAR REACTION, TYPE III, K_mAmAb

The minimum current for a highly excitable specimen of Mimosa for the exhibition of the first type of response K_m , was found to be 2 micro-amperes, and 4 micro-amperes for

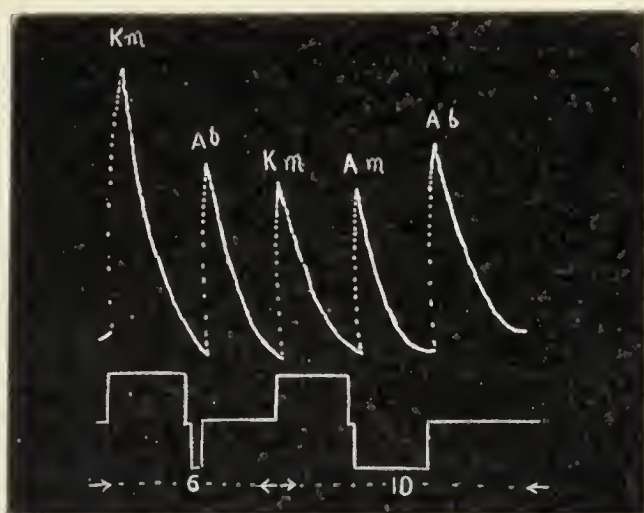

FIG. 66. Effect of increasing intensity of current in transforming response K_mAb of Type II to response K_mAmAb of Type III.

the second type K_mAb . It must be borne in mind that the minimally effective current depends on the excitability of the tissue, and therefore varies with the tonic condition of the plant.

Experiment 59. *Transformation of type under increase of current.*—The following shows the gradual transformation of the type of response in an identical specimen under gradual increase of current. The specimen was moderately sensitive, and the minimum current for excitation only at K_m was found to be 3.5 micro-amperes. When the current was increased to 5.6 micro-amperes, excitation occurred at kathode-make and at anode-break, the formula being K_mAb . When the current was further increased to 6.3 micro-amperes, a new

and unexpected type of reaction made its appearance. Excitation was produced not only at kathode-make and anode-break, but also at anode-make. The excitation formula is therefore $KmAmAb$.

I reproduce a record of this transformation under increased intensity of current. Application of a current of 6 volts had given rise to excitation at kathode-make and at anode-break ; but current increased up to 10 volts gave rise to excitation at kathode-make, anode-make and anode-break (fig. 66).

POLAR EXCITATION, TYPE IV, $KmKbAmAb$

Experiment 60. *Excitation with stronger current.*—The experiment was continued with the above specimen with

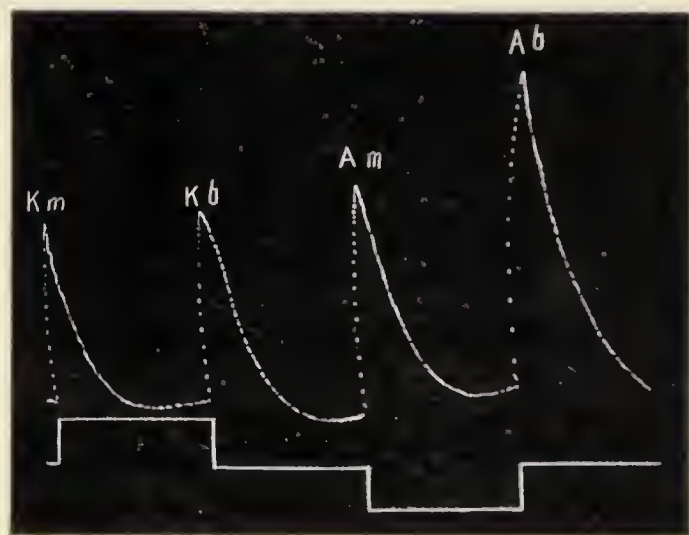

FIG. 67. Polar excitation, Type IV, $KmKbAmAb$.

this difference, that the current was further increased to 12.7 micro-amperes. This gave rise to the fourth type of reaction, namely, excitation at make and break of kathode, and at make and break of anode (fig. 67). The excitation formula of the fourth type is thus $KmKbAmAb$.

The following is a tabular statement of typical results obtained with a moderately sensitive pulvinus of *Mimosa* under increasing intensity of current.

TABLE VIII.—POLAR ACTION OF CURRENT OF INCREASING INTENSITY ON PULVINUS OF MIMOSA.

Intensity of current in microamperes	Excitation induced	Characteristic type
3.5	Km	Type I
5.6	KmAb	Type II
6.3	KmAmAb	Type III
12.7	KmKbAmAb	Type IV

In order to avoid complications which might possibly arise from fatigue induced by protracted experiments carried out with the same specimen, I repeated the experiments with fresh specimens which fully confirmed the previous results. The value of the effective current for each type is to a certain extent modified by the sensitivity of the organ, by its age and by the season ; a highly excitable specimen as a rule requires a feebler current than a less excitable one.

POLAR REACTION OF LEAFLETS OF VARIOUS SENSITIVE PLANTS

Experiment 61.—The characteristic reactions to current of increasing intensity are exhibited not merely by the leaf of *Mimosa* but also by the leaflets of all sensitive plants such as those of *Biophytum* and *Averrhoa*. I give below the results obtained with leaflets of *Mimosa*, which may be taken as typical of the others.

TABLE IX.—EFFECTS OF CURRENT OF INCREASING INTENSITY ON LEAFLETS OF MIMOSA.

Intensity of current in microamperes	Excitation induced	Characteristic type
0.75	Km	Type I
2.5	KmAb	Type II
5.0	KmAmAb	Type III
12.0	KmKbAmAb	Type IV

Pflüger's Law of Polar Excitation of animal tissues covers only the first two types, and is therefore not a complete statement of the polar action of current. It is necessary to include the following :

Supplementary Laws of Polar Excitation of Strong Current—

(III) UNDER THE ACTION OF A STRONG CURRENT, EXCITATION TAKES PLACE AT KATHODE-MAKE, AT ANODE-MAKE, AND AT ANODE-BREAK.

(IV) UNDER STILL STRONGER CURRENT, EXCITATION OCCURS AT KATHODE-MAKE, AT KATHODE-BREAK, AT ANODE-BREAK, AND AT ANODE-MAKE.

The existence of Types III and IV has been denied and attempts made to explain them by the assumption of production of secondary poles by the strong currents employed. The meaning of secondary poles will be understood from the experiments of Engelmann and Biedermann on the ureter of the rabbit. They observed that, in an *insulated specimen*, a moderate current induced excitation only at kathode-make and at anode-break, the excitation formula being the normal KmAb. But the polar reactions were found to be reversed into AmKb when the specimen, *instead of being insulated*, was placed on a good conducting support such as salt clay. The kathode now caused excitation not at make but at break, and the anode at make instead of at break. This reversed action AmKb was explained by the fact that the conducting clay, on which the uninsulated specimen was placed, gave rise to diffusion of the current and resulting development of secondary poles.

How is the reversal of normal reaction to be explained? Why did the kathode fail to excite at make but caused excitation at break? Why again did the anode cause excitation at make and not at break? It is the production of secondary poles that is supposed to be responsible for the reversal of normal reactions. The anode excited at make because there were numerous secondary kathodes produced

in the neighbourhood. The kathode failed to excite at make because of the depressing action of the secondary anodes.

The excitatory reactions of the Types III and IV cannot, however, be explained by any assumption of secondary poles for the following reasons :

- (1) The improbable hypothesis of the formation of secondary poles by a strong current does not explain the observed phenomena, for the induction of secondary poles would have produced excitation only at anode-make and none at kathode-make. But under strong current, excitation occurs not only at kathode-make but also at kathode-break. Excitation is, moreover, produced by the anode both at make and break. The conditions of the experiment, again, made the production of secondary poles impossible, as explained below.
- (2) The electric connexions consisted of moist thread making a complete loop round the pulvinus, which was thus equally and throughout its circumference kathode or anode as the case might be. The organ, like the insulated ureter, was perfectly isolated, so that the conditions for the production of secondary poles were entirely absent.
- (3) I carried out other experiments in which the electric connexion was made by thrusting a platinum pin into the sensitive cortex, which was thus directly acted upon by the current. Under these conditions there could be no possibility of the production of secondary poles. Nevertheless the four types of reaction were observed under current of increasing intensity.
- (4) The effects of feeble and of moderate current were perfectly normal. But when with the same specimen and with identical connexions the intensity of

the current was increased, the excitatory reactions became gradually transformed and in definite sequence, first into Type III, *i.e.* excitation at kathode-make, at anode-make and anode-break; and subsequently, under still stronger current, into Type IV with excitation at kathode-make, kathode-break, anode-make and anode-break.

The results given above fully establish the supplementary laws of polar action with strong current.

POLAR EXCITATION OF ORDINARY PLANTS

The characteristic polar reactions are exhibited not only by sensitive plants but by all plants. I give below the summary of results obtained with Balsam, which may be taken as typical, the response being recorded by the movement of the leaf.

Experiment 62.—The excitability of ordinary plants being less than that of sensitive plants, the minimum current for each type of reaction has to be proportionately increased. Thus in Balsam (*Impatiens*) a minimum current of 8.5 micro-amperes was found necessary for the first type Km, the responding leaf exhibiting a contractile fall. When the current was increased to 12.5 micro-amperes, excitation occurred at kathode-make and at anode-break. Further increase of current to 18 micro-amperes gave rise to reactions of Type III; still stronger current, *i.e.* 20 micro-amperes, caused transformation to Type IV.

TABLE X.—EFFECTS OF CURRENT OF INCREASING INTENSITY ON ORDINARY PLANTS (*IMPATIENS*).

Intensity of current in microamperes	Excitation induced	Characteristic type
8.5	Km	Type I
12.5	KmAb	Type II
18.0	KmAmAb	Type III
20.0	KmKbAmAb	Type IV

SUMMARY

Protoplasmic excitation is induced in plants by the polar action of a constant current. The characteristic reactions are exhibited not only by sensitive but also by ordinary plants. The phenomena may therefore be regarded as universal.

The following Laws of Polar Excitation in Plants under feeble and moderate currents have been established :

- (I) With feeble current, excitation takes place only at kathode-make.
- (II) With a current of moderate intensity, excitation occurs at kathode-make and at anode-break.

The polar reactions of the undifferentiated protoplasm of the plant-body are thus identical with those of highly differentiated animal tissues.

With stronger current, two other types of reaction are manifested. The Supplementary Laws of Polar Excitation in Plants are :

- (III) With a strong current, excitation takes place at kathode make, at anode-make, and at anode-break.
- (IV) With still stronger current, excitation occurs at kathode-make, at kathode-break, at anode-make, and at anode-break.

CHAPTER X

THE RESPONSE OF THE ISOLATED PULVINUS

IT was shown in a previous chapter that the irritability of the leaf of *Mimosa* could be maintained constant even when borne on a stem detached from the parent plant. Could we proceed still further and, getting rid of all unnecessary appendages, obtain the contractile response of the pulvinus *itself*? An isolated muscle, kept under proper conditions, continues to exhibit its contractility unchanged for many hours. Would it be possible to secure an isolated pulvinus which, like the isolated muscle, would respond to stimulation by contraction?

ISOLATED PULVINAR PREPARATION

In order to reduce the shock-effect of operation, the pulvinus was benumbed by local application of ice-cold water. It was then cut off at its junction with the stem, leaving only a strip of epidermis attached to the upper half of the pulvinus. The petiole was left as a convenient handle for manipulation. The sub-petioles may be allowed to remain or may be removed; in the latter case the cut end of the petiole is closed by flexile to prevent rapid loss of water by evaporation.

The petiole was held by a clamp so that the more excitable half of the pulvinus remained in the normal lower position. A short silk string tied to the strip of epidermis

projecting from the upper half of the pulvinus, was attached to the short arm of a recording-lever (fig. 68). The response curve was traced on an Oscillating Recorder, the successive dots of which were at intervals of 2 minutes.

Method of stimulation.—The terminals of the secondary of an induction-coil were connected by flexible silver tinsel, one electrode to the end of the strip of epidermis E, and the

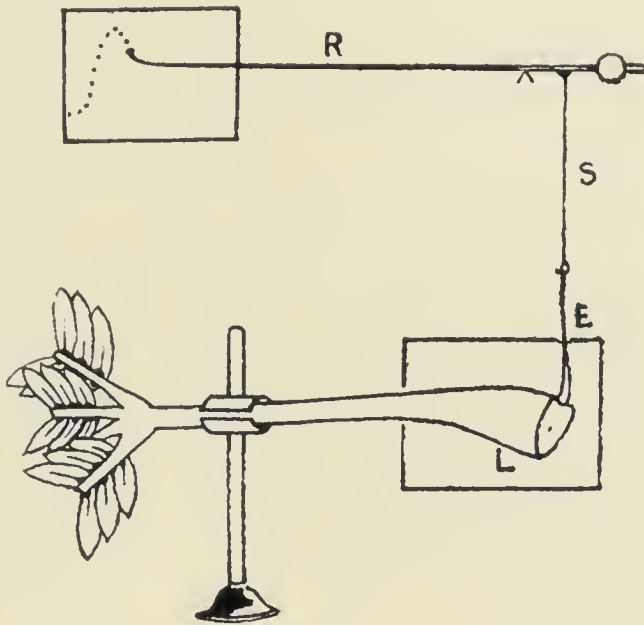

FIG. 68. Recorder for isolated pulvinus of Mimosa.

L, lower half of pulvinus facing downwards; E, strip of epidermis tied to string s attached to short arm of recording-lever R. The pulvinus is enclosed in a small chamber.

other to the petiole. Induction-shocks of definite intensity and duration could thus be passed through the pulvinus at regular intervals.

The plant-chamber.—This was made very light and compact, the size of the chamber being a cube $5 \times 5 \times 5$ c.cm. The sides of the chamber consisted of thin sheets of mica. The strip of epidermis E passed through a narrow aperture for attachment to the recorder. Moist blotting-paper maintained the interior of the chamber in a proper humid condition. A small piece of cloth moistened with highly

dilute glycerine was applied against the cut end of the pulvinus to prevent drying of the tissue.

THE PULVINAR RESPONSE

After carrying out all necessary precautions, I tried if stimulation would cause a down-curvature of the pulvinus by the greater contraction of its more excitable lower half. But the recording-lever showed no indication of such a movement. The pulvinus had evidently lost its contractility in consequence of the drastic treatment to which it had been subjected, the severe shock of the operation. It then

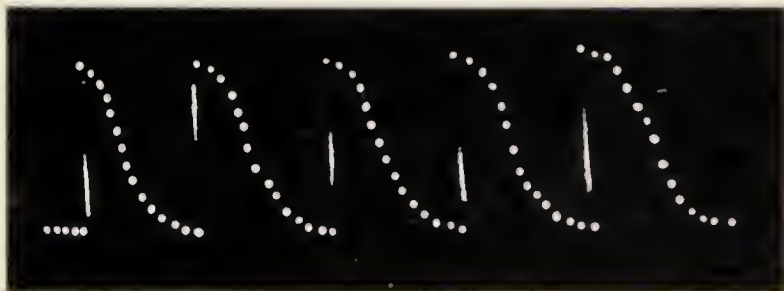

FIG. 69. Uniform response of isolated pulvinus (*Mimosa*).

occurred to me that the lost power of contraction might possibly be restored after a suitable period of rest. The surmise was justified by results of the following experiments.

Experiment 63. *Uniform response under stimulation.*—After allowing an hour's rest, the contractility of the isolated pulvinus was found to have become restored. I reproduce a series of responses recorded at intervals of 28 minutes (fig. 69) which show the extraordinarily uniform character of the responses.

The responsive contraction and curvature of the pulvinus was recorded by the recording-lever as an up-curve. The intensity of stimulus was 3 units and the duration of stimula-

tion was 0·2 second. The contraction was very rapid and the maximum contraction was observed to be completed, as in an intact plant, in the course of less than 2 seconds. On account of the rapidity of movement of the recording-lever during the phase of contraction, the record appears as a scratch. The recovery was slow, as indicated by successive dots made at intervals of 2 minutes. It will be noticed that the period of complete recovery here was about 28 minutes, instead of 15 minutes as in intact plants. The following considerations offer an explanation of this difference. It has been explained how the expansive recovery of the contracted pulvinus is hastened by the active supply of sap in the intact plant. In the isolated pulvinus, on the other hand, expansion depends upon the relatively slow absorption of water from the moist cloth applied against the cut end of the pulvinus.

The most important lesson learnt from the experiment is that *the lost irritability of the pulvinus due to rough handling or even to the severe shock of wound, is restored after a suitable period of rest.*

The irritability of the pulvinus is thus practically independent of the plant. The isolated pulvinus, on account of the smallness of its size, offers exceptional advantages for many investigations; several researches, in fact, have been rendered possible which were impracticable even with the petiole-pulvinus preparation.

The reliability of this method in general investigations on irritability will be understood from the following accounts of experiments on the action of different gases and vapours, and also of different drugs in solution. Gases and vapours can be easily introduced into or removed from the plant-chamber by means of a pair of inlet and outlet pipes. As regards the action of chemical solutions, the liquid drugs had hitherto been applied indirectly at the cut end of the stem, relying on the slow rise of sap to carry it to the pulvinus. In the present case the application is direct and there was

no delay in inducing the characteristic reaction. The solution is applied, by means of a pipette, to the strip of epidermis projecting above the chamber. The liquid trickles down and is quickly absorbed by the exposed cut end of the pulvinus.

EFFECT OF CARBONIC ACID GAS

The depressing action of strong application of this gas has already been described (*cf.* fig. 43).

Experiment 64.—The record (fig. 70) exhibits the effect of continued application of dilute CO_2 ; the result is a

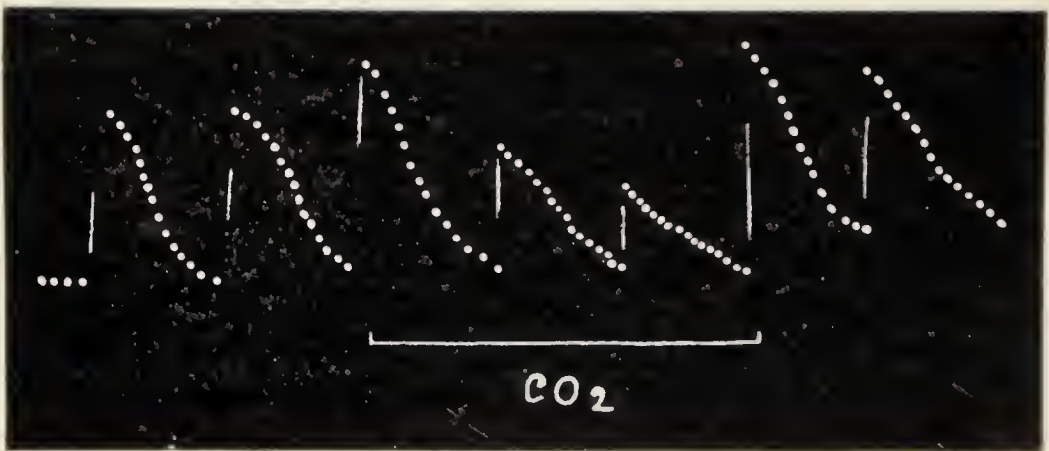

FIG. 70. Effect of CO_2 on response of pulvinus.

Note preliminary stimulation followed by depression; normal excitability restored after removal of gas (*Mimosa*).

preliminary stimulation followed by depression; substitution of fresh air was followed by restoration of normal excitability.

EFFECT OF CHLOROFORM

Experiment 65.—Two drops of chloroform were dropped into the plant-chamber, and the rising vapour, at first very dilute, gradually increased in strength. The stimulating effect of the minute dose is seen in an enhancement of the response; continued action of the stronger dose induced, however, depression (fig. 71); when liquid chloroform was

applied at the cut end of the pulvinus, the response became permanently abolished (*cf.* fig. 46).

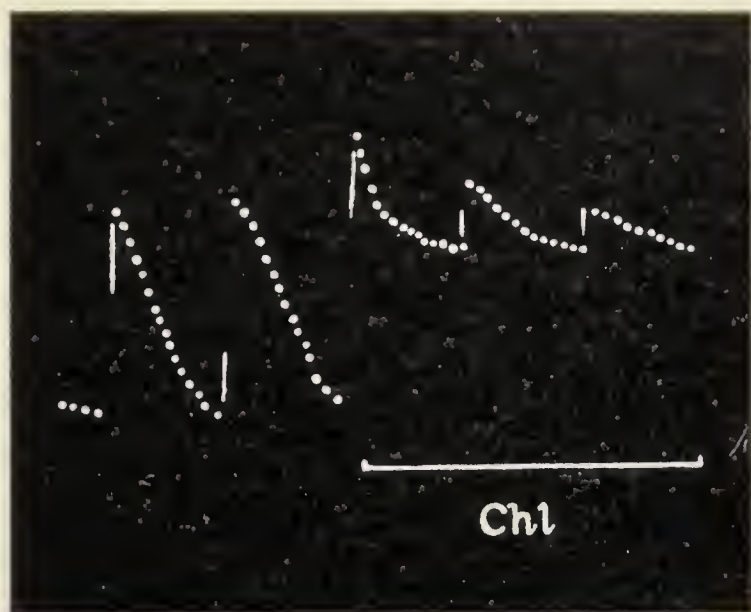

FIG. 71. Effect of Chloroform on pulvinar response (*Mimosa*).

EFFECT OF STIMULANTS

With regard to the demonstration of the action of a stimulating reagent, it may be said, in general, that a tissue in a slightly depressed condition exhibits the effect in a very striking manner: for then the responsive contraction of the highly excitable tissue is the maximum possible and cannot therefore be exceeded.

I have carried out a large number of experiments on the action of various drugs in solution, of which a few typical examples are given below.

EFFECT OF DILUTE SOLUTION OF CAMPHOR

Experiment 66.—After taking three normal responses, very dilute solution of camphor was applied at the cut end of the pulvinus. This is seen to have induced a very great increase in the amplitude of the contractile response (fig. 72).

The specific action of camphor was so marked that I was led to investigate its action on the contractile response of frog's muscle.

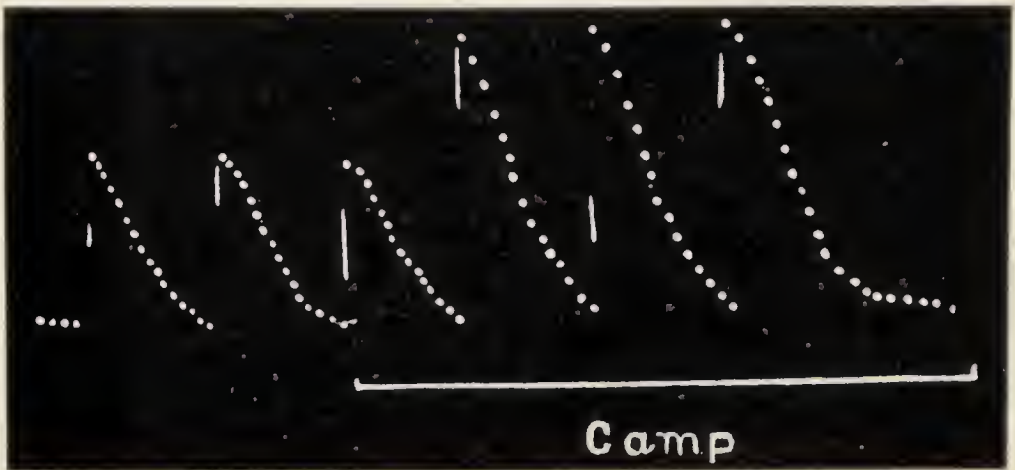

FIG. 72. Stimulating action of Camphor on pulvinar response (Mimosa).

ACTION OF CAMPHOR ON RESPONSE OF ANIMAL MUSCLE

Experiment 67.—The myogram of frog's sartorius was taken on a fast-moving drum under minimally effective stimulation, which was kept constant for the succeeding

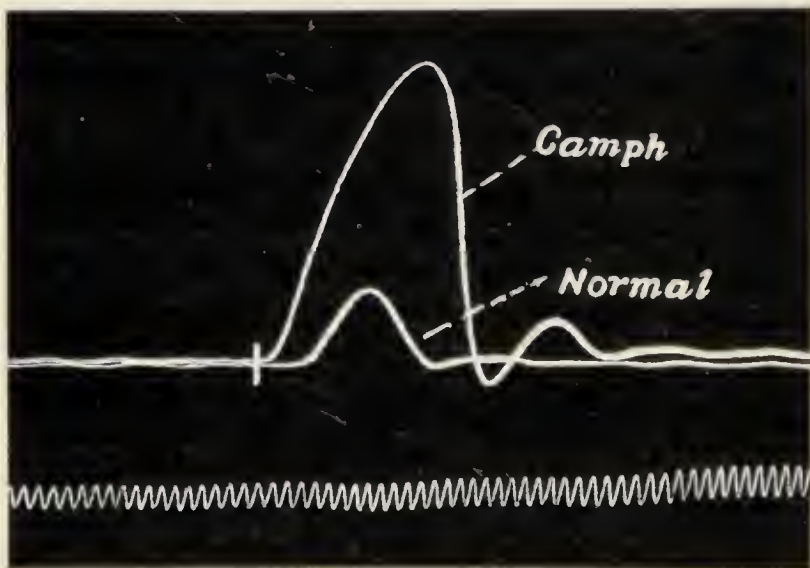

FIG. 73. Stimulating action of Camphor on response of Frog's muscle.
Tuning-fork tracings 100 in a second.

experiment. After the first normal response a second was taken after application of dilute camphor solution. The amplitude of response is seen to have undergone a marked increase (fig. 73). This identical effect of a specific drug on the contractile tissues of both animal and plant is highly significant.

ACTION OF CAFFEIN

Experiment 68.—A 4 per cent. solution of caffein caused an enhancement of excitability, but continued appli-

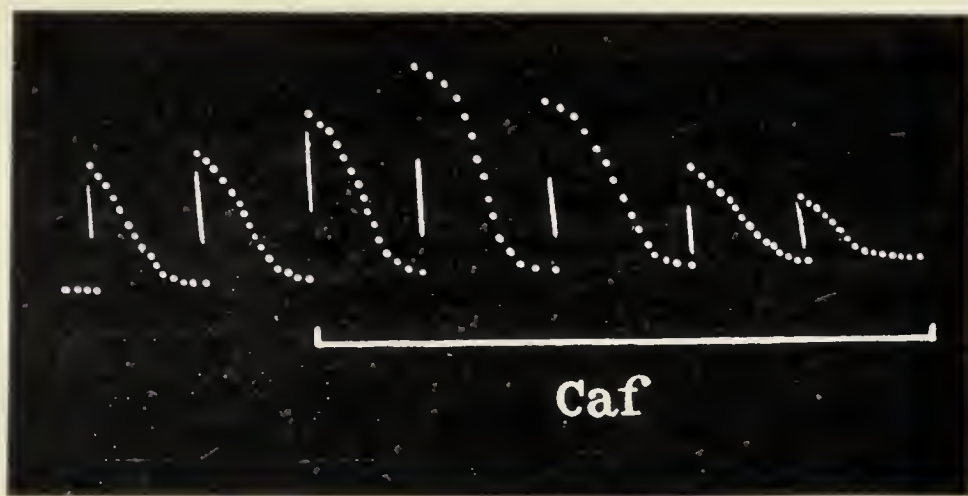

FIG. 74. Stimulating action of Caffein on pulvular response. Continued application caused depression (Mimosa).

cation induced depression (fig. 74). It should be remembered in this connexion that both the amount of the dose and the duration of the application are matters of importance; for even a stimulating agent in large quantities is apt to exert a depressing effect.

ACTION OF MUSK

Experiment 69.—A 2 per cent. solution of this well-known cardiac stimulant was found to exert a

stimulating action on the contractile response of the pulvinus (fig. 75).

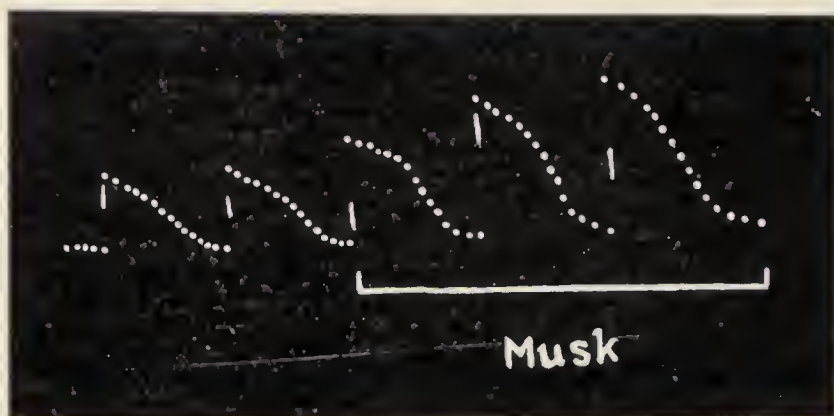

FIG. 75. Stimulating action of Musk on pulvinar response.

ACTION OF STRYCHNINE

Experiment 70.—A small dose of strychnine was found to induce a great enhancement of excitability. This was

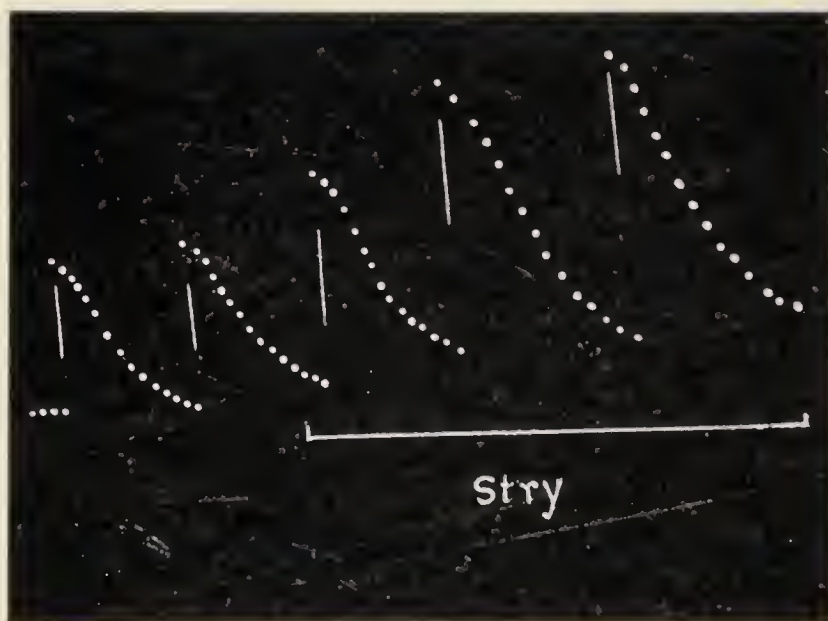

FIG. 76. Enhancement of amplitude of pulvinar response under minute dose of Strychnine (*Mimosa*).

shown by the fact that a sub-minimal stimulus which was ineffective proved to be fully effective after the application

of strychnine. Feeble contraction was, moreover, greatly increased under the action of a minute dose of this drug (fig. 76).

Experiment 71.—A similar enhancement of contractile response also occurred in frog's muscle under the action of a minute dose of strychnine (fig. 77).

In previous chapters it has been shown how essentially similar are the contractile responses of plant and animal, and how similarly they are modified by parallel variations of external conditions. In both, individually ineffective

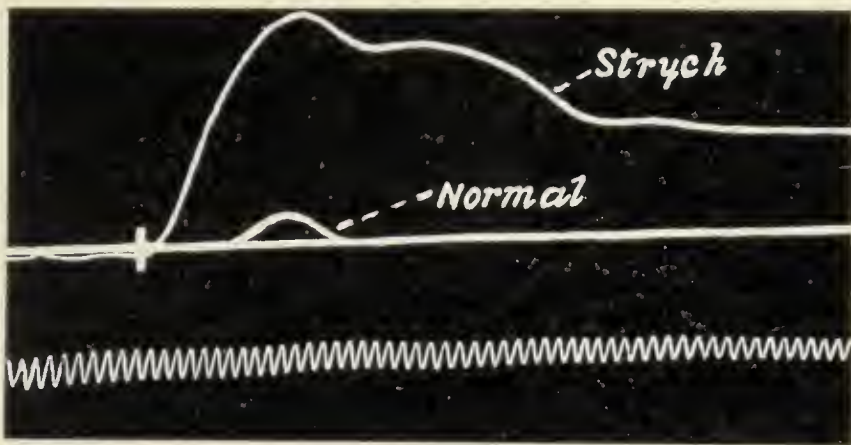

FIG. 77. Effect of minute dose of Strychnine in enhancing the contractility of Frog's muscle.

stimuli become effective on repetition. They both exhibit 'staircase' increase of response, and decline under fatigue. Temperature has a similar effect on both. The presence of some 'active substance' enhances the rapidity of reaction of both. And in both, finally, the response is modified in an identical manner by the specific action of drugs. In these circumstances the pulvinus of *Mimosa* may justifiably be regarded as its 'muscular' tissue.

SUMMARY

The pulvinus of *Mimosa* loses its power of contraction immediately after isolation of the leaf from the plant. This

is due to the paralysing effect of the shock of operation ; the moto-excitability is, however, restored after a suitable period of rest.

Under uniform external conditions the responses remain uniform for a considerable length of time. The isolated pulvinus can therefore be employed with success for all investigations on the moto-excitability of the plant. In certain respects it offers greater facilities for investigation.

The specific actions of various drugs are found to be essentially the same in plant and in animal.

CHAPTER XI

MEASUREMENT OF THE CONTRACTION OF ACTIVE CELLS

ALL life-movements are ultimately due to contraction of the smallest unit of life, the individual cell, an aggregation of which constitutes the living organism. It is the additive effect of the infinitesimal contraction of an almost countless number of active cells in the lower half of the pulvinus of *Mimosa* that brings about the strikingly impulsive fall of the leaf. By the tedious process of counting the cells in stained sections of the pulvinus, the number of active cells was found to exceed a hundred thousand.

The question arises: Would it be possible to measure the extraordinarily minute contraction of a definite number of these cells under stimulation, and thus to obtain a clearer idea of the cellular mechanism? The use of the microscope for the observation of cellular contraction in the interior of an opaque tissue is obviously impossible. Even if it were possible to make the pulvinus transparent, the contraction of an individual cell would be beyond the power of the microscope to detect. I nevertheless hoped to be able to observe the total contraction of a row of cells in a microscopic section of the pulvinus about 2 cells in thickness, but the severe shock of operation was found to have effectively killed the cells. I tried to overcome the difficulty by benumbing the tissue before making the necessary section; but attempts to keep the section alive have hitherto proved to be unsuccessful. With greater experience, it may perhaps be possible to overcome the difficulty.

The problem of measurement of the responsive contraction of a row of cells was, however, solved by a new method which will be described in this chapter.

The following facts have been established in regard to contraction of the active cells in the pulvinus of *Mimosa* :

- (1) The pulvinus, as seen in longitudinal section, consists mainly of two masses of cortex separated by a thin vascular strand. The active contractile cells can be sharply discriminated from the inactive by means of selective staining (*cf.* fig. 35).
- (2) The mass of cortex in the upper half of the pulvinus is relatively unexcitable, its contraction even under moderate stimulation being practically negligible compared with that of the more excitable lower half (*cf.* Experiment 12).
- (3) Hence under medium stimulation the cellular contraction may be regarded as practically confined to the lower half of the organ.

METHOD OF DIAMETRIC CONTRACTION

Let us visualise a vertical row of actively contractile cells placed between two rods of german silver, the upper and shorter being fixed, while the lower and longer rod is movable, functioning as a magnifying primary lever. A short length of the primary lever towards the left is flattened into a spring and thus acts as a flexible hinge H. The two diametric points of contact are at C C'; the spring also serves to keep the lever pressed against the lowermost cell. On stimulation the vertical length of the row of cells becomes contracted and shortened. The upper rod being fixed and immovable, the shortening of the row of cells makes the lower lever move upwards, thus indicating the diametric contraction of the row of cells. The actual shortening is magnified by the lever in the ratio of $\frac{HL}{HC'}$ (fig. 78).

I return from the theoretical to the practical method of experimentation on a pulvinus. For facility of manipulation it is more convenient to employ a cut stem bearing a leaf, in place of an entire plant, the cut end being placed in a small vessel of water. The shock-effect of the operation is, as previously stated, minimised by previously benumbing the stem with ice at the place of section. The normal excitability of the specimen is fully restored in the course of about 2 hours.

In the diagrammatic representation of the apparatus a vertical section of the pulvinus is indicated between the

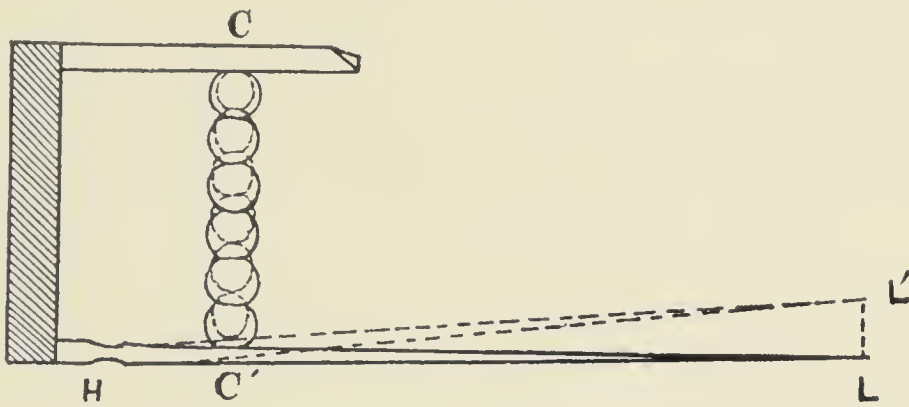

FIG. 78. Diagrammatic representation of the measurement of diametric contraction.

Row of cells between fixed rod *c* and flexible lever *HL*.
Contraction produces up-movement *L L'*.

fixed upper rod and the movable lever below, the diametric points of contact being *C C'*. The contraction of the vertical layer of active cells, as already explained, is indicated by a very slight and almost imperceptible up-movement of the primary lever, which magnifies 30 times. Further magnification was necessary and was produced by linking the end of the first lever to the short arm of a secondary recording-lever *R*, which magnifies 150 times (fig. 79): the total magnification is therefore 4500 times. With this arrangement the amplitude of response under strong stimulation sometimes proved to be too great for reproduction; the magnification had then to be suitably reduced to either 2000 or 1000 times.

The over-weight of the longer arm of the recording-lever keeps the contact point of the first lever C' always pressed against the pulvinus with a moderate pressure. Diametric contraction of the pulvinus under stimulation causes an up-movement of the first, and a down-movement of the second lever, the record being a down-curve. For convenience of inspection the record is printed upside down, so that the magnified contractile response would appear as an

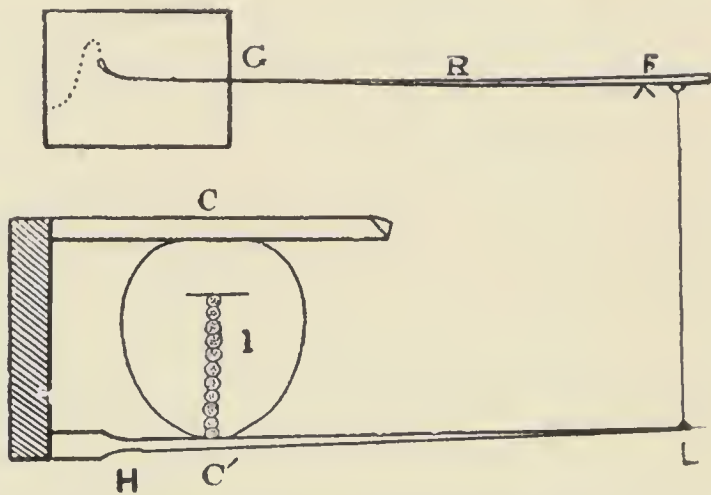

FIG. 79. Diagrammatic representation of recorder of diametric contraction of pulvinus of *Mimosa*.

Vertical section of pulvinus shown in figure of which l is the row of more effective contractile cells in lower half of pulvinus. Movement of primary lever L , further magnified by recording-lever R .

up-curve, while the down-curve exhibits the expansive movement of slow recovery.

It is convenient to give the instrument a shorter name than that of Recorder of Cellular Contraction. It records not only the contraction but also the concomitant variation of pressure. In normal condition the cells charged with sap are tense and their aggregate pressure may be described as the sap-pressure. Stimulation causes contraction and expulsion of sap from the cells with resulting diminution of pressure. During recovery there is an absorption of sap, with expansion and a gradual restoration of the original pressure. The instrument therefore records not merely

contraction or expansion, but also the corresponding diminution or increase of pressure. I will therefore designate the apparatus as the Cell-Sphygmograph, of which there are three types varying in sensitiveness. For the present purpose a magnification of 1000 to 5000 times is quite sufficient.

THE AUTOMATIC CELL-SPHYGMOGRAPH

The apparatus and general experimental arrangement is shown in fig. 80, reproduced from a photograph. The

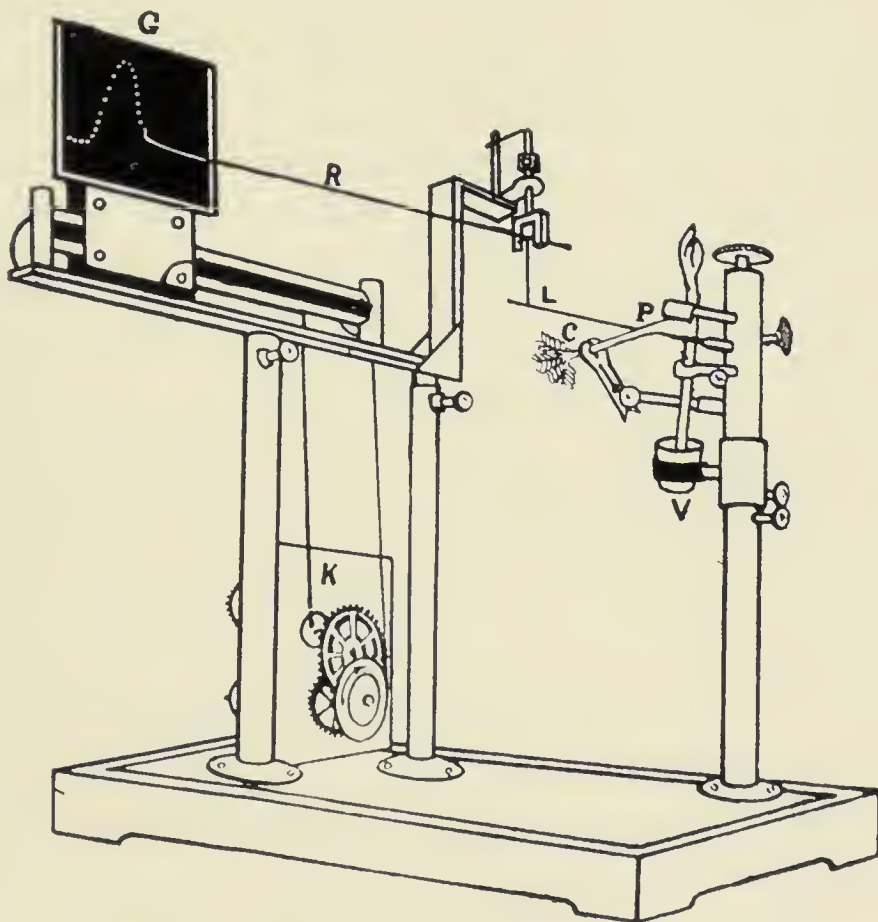

FIG. 80. The Automatic Cell-Sphygmograph.
(From a photograph.)

Leaf of *Mimosa* held rigid by clamp *c*. Pulvinus placed between a fixed rod and a movable lever *L*, attached to short arm of recording-lever *R*.

record is taken on an Oscillating Recorder, the successive dots being at intervals of 5 seconds. The plant, after being

suitably mounted on the apparatus, is allowed a period of rest of 1 to 2 hours, after which the normal excitability is fully restored. An induction shock sent through the pulvinus would cause the fall of the leaf, a *down-movement* of the first lever and a very large *up-movement* of the recording-lever. But the fall of the leaf indicates merely the *force of contraction* and not the contraction itself. For the measurement of the contraction of the vertical row of cells, the two opposite contacts of the pulvinus with the two sphygmographic rods must always be maintained unbroken. The fall of the leaf would, however, break the contact with the upper rod; to prevent this the leaf is restrained from falling, by being held rigid by a clamp. This is found in no way to interfere with the fundamental contraction of the cells under stimulation. The fall of the leaf is a remote consequence of contraction; hence restraint imposed on the leaf does not interfere with the primary reaction. This is fully confirmed by the results of experiments to be presently described.

I draw attention to the characteristic difference in the sign of the recorded response of the downward pull exerted by the falling leaf, and that of the fundamental cellular contraction. In the first case the unrestrained leaf would cause by its fall a *down-movement* of the primary lever; in the second case the diametric contraction of active cells of the pulvinus of the restrained leaf causes an *up-movement* of the lever.

CELLULAR CONTRACTION UNDER STIMULATION

The maximum cellular contraction occurred in the course of 2 seconds, which is also the period for the maximum fall of the free leaf. The period of expansive recovery of the contracted cells was about 15 minutes or so. The sphygmographic record of cellular contraction and subsequent expansion (*see* fig. 81) is thus essentially similar to the phytographic record of the responsive fall and subsequent

erection of the leaf. *There are thus two independent ways of determining the fundamental excitatory reaction, namely by the Sphygmograph and by the Phytograph.* The cause of similarity between the two responses is found in the fact that in the one the contraction is recorded directly, and in the other indirectly by the fall of the leaf, which is a remote consequence of the cellular contraction.

We are next confronted with the following questions :

- (1) What is the vertical length of the contractile cell ?
- (2) What is the absolute value of its diametric contraction and the percentage of contraction ?
- (3) What is the approximate size and amount of contraction of an individual cell ?

The results of experiment and the quantitative values given below are the answers to the above questions.

I applied successfully feeble, moderate, and strong stimulation ; in every case a marked contractile response was recorded, the amplitude of response increasing with increased intensity of stimulation. The record of response under stimulus of feeble intensity taken under a magnification of 4500 times was too large to be contained in a page. I therefore reproduce (fig. 81) a typical record obtained under the low magnification of 2000 times, the stimulus being of moderate intensity.

The recorded movement was due to the contraction of the vertical row of active cells in the line of sphygmographic contact CC' (fig. 79). The responsive movement is extremely small and will be expressed either in microns or in millionths of an inch. The former, represented by the symbol μ , is a millionth of a metre. One micron is equal to 40 millionths of an inch.

It has been explained that under medium stimulation the sphygmographic response is due practically to the contraction of the row of vertical cells l in the lower half of the pulvinus. After record of contraction, the measurement of this length was made as follows : a transverse microscopic

section of the pulvinus was made at the line which passed through C C', the differential staining of which clearly brought out the actively contractile cells. The length l was measured by a microscope micrometer, and the number of cells n counted at the same time.

Vertical length of contractile cell.—The following results were obtained with the experimental pulvinus, which was of an average size.

Length of vertical row of active cells $l = 0.5$ mm. (1)

The number of cells $n = 21$ (2)

It may be said in passing that the length varies in different specimens from 0.45 to 0.6 mm., and the number of cells in the row from 19 to 24.

EFFECT OF FEEBLE STIMULATION

Experiment 72. *Effect of feeble stimulation.*—The amplitude of the contractile response was 70 μ ., obtained under a magnification of 4500 times. Hence

$$\begin{aligned} \text{Absolute diametric contraction of } l &= \frac{70}{4500} \\ &= 0.016 \text{ mm. or } 16 \mu \\ &= 640 \text{ millionths of an inch} \end{aligned} \quad \left. \vphantom{\frac{70}{4500}} \right\} \cdot \quad (3)$$

From data given in (1) (2) and (3) the following calculations have been made :

$$\begin{aligned} \text{Average diameter of individual cell} &= \frac{0.5}{21} \\ &= 0.024 \text{ mm. or } 24 \mu \\ &= \frac{1}{1000} \text{ inch nearly} \end{aligned} \quad \left. \vphantom{\frac{0.5}{21}} \right\} \cdot \quad (4)$$

$$\begin{aligned} \text{Diametric contraction of a single cell} &= \frac{16 \mu}{21} \\ &= 0.76 \mu \\ &= 30 \text{ millionths of an inch.} \end{aligned} \quad (5) \text{ Amount of contraction under feeble stimulation} \\ = 3.2 \text{ per cent.} \quad \cdot \quad \cdot \quad \cdot \quad (6)$$

Experiment 73. *Effects of moderate and strong stimulation.*—A record was taken under stimulation of moderate intensity, the magnification being 2000 times (fig. 81). Another record obtained under strong stimulation gave



FIG. 81. Record of diametric contraction of pulvinus of *Mimosa*, under moderate stimulation (magnification 2000 times).

response of greater amplitude. The percentage of contraction for feeble, moderate, and strong stimulation, calculated from the results of the experiments described, are given below :

Amount of contraction under feeble stimulation	=	3·2 %
„ „ „ moderate „	=	5·7 %
„ „ „ strong „	=	13·3 %

The active cells of the pulvinus are thus found to undergo very marked contraction under stimulation ; though the amount of contraction is beyond the power of the microscope to detect, yet the contraction of even an individual cell has

been measured with a considerable degree of accuracy. The rate of contraction is also very rapid, this being due to the presence of some 'active substance' in the pulvinar cells of *Mimosa*.

Hitherto the pulvinus of sensitive plants like *Mimosa* have been alone regarded as sensitive. Is there any justification for this view? The cortex of the pulvinus of *Mimosa* is continuous with that in the stem. Does the contractility of the cortex abruptly end at the pulvinar limit or does it also extend into the stem? If so, what is the amount of contraction? Is it of the same or of a very different order from that of the contractile cells in the pulvinus? In other words, are all cortical cells sensitive, and do they respond to stimulation by contraction?

DIAMETRIC CONTRACTION OF CORTICAL CELLS IN THE STEM

The investigation was carried out with the identical specimen employed in the foregoing record of pulvinar contraction. The stem, at a short distance below the pulvinus, was mounted horizontally between the two contact-points of the Sphygmograph.

A modification of the experiment enables the stem to be maintained in the normal vertical position, in which case the sphygmographic contacts would be in a horizontal plane. It was, however, thought desirable to employ the same recording apparatus for measurement of the diametric contraction of the cortical cells in both the pulvinus and in the stem, so that the results might be strictly comparable.

Since the excitability of radial stems is the same all round, the diametric contraction, if any, would occur on both sides of the stem. The sum of the depths of the cortex on two sides will be represented by l , and the number of cortical cells in the same row between the two sphygmographic contacts by n . The length l and the number n were found in

the usual manner by microscopic examination of the section made after the experiment. In the present case,

Sum of the thickness of the cortex on the
two sides $l = 0.2$ mm. (7)

Number of cortical cells between contact
points $n = 14$. (8)

Experiment 74. *Effect of feeble stimulation.*—The stem was subjected to electric stimulation of the same intensity as in the case of the pulvinus. This gave rise to a diametric contraction of the cortex, the amplitude of which was 18 mm. at a magnification of 4500. This proves that *contractility is not confined to the pulvinus but is also characteristically present in the stem.*

The absolute diametric contraction is

$$l = \frac{18}{4500} = 0.004 \text{ mm.} \quad . \quad . \quad . \quad (9)$$

Average diameter of individual cell

$$= \frac{0.2}{14} = 0.014 \text{ mm.} \quad . \quad . \quad . \quad (10)$$

Diametric contraction of a single cell

$$= \frac{0.004}{14} = 0.29 \mu$$

$$= 11.6 \text{ millionths of an inch} \quad (11)$$

Amount of contraction 2 per cent. . . . (12)

Effect of moderate stimulation.—The experiment was repeated under stimulation of stronger intensity; the record is given in fig. 82. Comparison of figs. 81 and 82 will show how essentially similar are the responses of the cortical cells in the pulvinus and in the stem. The percentage of contraction is of the same order; the rate of contraction of the cortical cells of the stem is less rapid on account of absence from them of 'active substance.'

To recapitulate the general results :

In the pulvinus the average diameter of an active cell is 0.024 mm., which in round numbers is a thousandth part

of an inch ; its diametric contraction under feeble stimulation is 0.76μ or about 30 millionths of an inch. The amount of contraction is 3.2 per cent.

In the stem the average diameter of each cortical cell is 0.014 mm. or 6 ten-thousandths of an inch. The amount of contraction is 2 per cent.

It will be seen that the contractility of the cortex of the stem is of the same order as that of the pulvinus. The

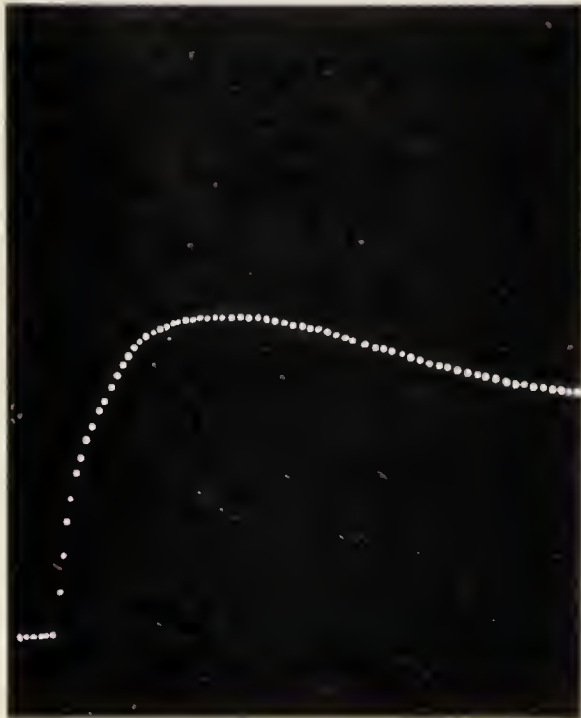

FIG. 82. Record of diametric contraction of cortex of stem of *Mimosa* (magnification 2000 times).

physiological mechanism is thus continuous in the stem and in the pulvinus ; the excitatory cellular reaction in the stem is essentially similar to that in the pulvinus. The cortex of the pulvinus, owing to the presence of the 'active substance,' reacts at a relatively quick rate. The difference is merely one of degree and not of kind.

Though the cortical cells of the stem are relatively sluggish in their reaction, yet they may, on this very account, have developed some special activity such as the power of

repeated contraction. That there is some justification for this surmise will be shown in a later chapter.

SUMMARY

The contractile reaction of the active cells in the pulvinus of *Mimosa* persists even when the leaf is prevented from movement. The fall of the leaf is a secondary consequence of the contraction of the pulvinar cells.

The size of a single contractile cell in the pulvinus is 0.024 mm. or about one thousandth of an inch in diameter. The diametric contraction under feeble stimulation is 0.76 μ or 30 millionths of an inch, which is beyond the highest power of the microscope to detect. The measurement has been rendered possible by the employment of the Cell-Sphygmograph. The amount of contraction under feeble stimulation is 3.2 per cent., increased to 13.3 per cent. under strong stimulation.

There is an uninterrupted continuity between the cortex of the pulvinus, of the petiole, and of the stem; the contractile mechanism is essentially similar throughout. The contraction of the cortical cells in the stem is of the same order as that of those in the pulvinus, being 2 per cent. under feeble stimulation. The diameter of each cell is 0.014 mm. or 6 ten-thousandths of an inch, the diametric contraction under feeble stimulation being 0.29 μ or 11 millionths of an inch.

The presence of 'active substance' in the cortical cells of the pulvinus apparently enables them to contract more rapidly than other cortical cells.

CHAPTER XII

MOTOR RESPONSE OF ORDINARY PLANTS

It has been shown in the previous chapter that the cortex of the pulvinus of *Mimosa* undergoes contraction under stimulation and that this can be detected in two different ways: namely, the diametric contraction of the active cells by the Cell-Sphygmograph, and the responsive movement of the leaf by the Phytograph. The records obtained by the two methods were further shown to be in every way similar to each other. The cortex of the pulvinar leaf-joint is continuous with that of the stem; it has been further shown that the contractile mechanism is also continuous: that is to say, that the cortex of the stem also exhibits contraction under stimulation, its contractility not being of a different order from that of the 'sensitive' pulvinus.

We are immediately confronted with the following questions:

- (1) Does the cortex of the stem of ordinary plants also undergo contraction on stimulation?
- (2) If so, of what order is the sensitivity of ordinary cortex?
- (3) What is the effect of intense stimulation on normal contractility?
- (4) Does the non-pulvinated leaf-joint of ordinary plants exhibit responsive movement similar to that of the pulvinus of *Mimosa*?

I was able to discover (1901) the universal sensitiveness of all plants by the method of electric response, a detailed

account of which is given in Chapter XIII. I have recently succeeded in obtaining mechanical response of ordinary plants to stimulation by the employment of a highly sensitive method of recording cellular contraction.

RESPONSE BY DIAMETRIC CONTRACTION OF ORDINARY STEMS

Experiment 75.—A direct record of the contraction of the cortical cells of a definite zone in the stem of *Impatiens*

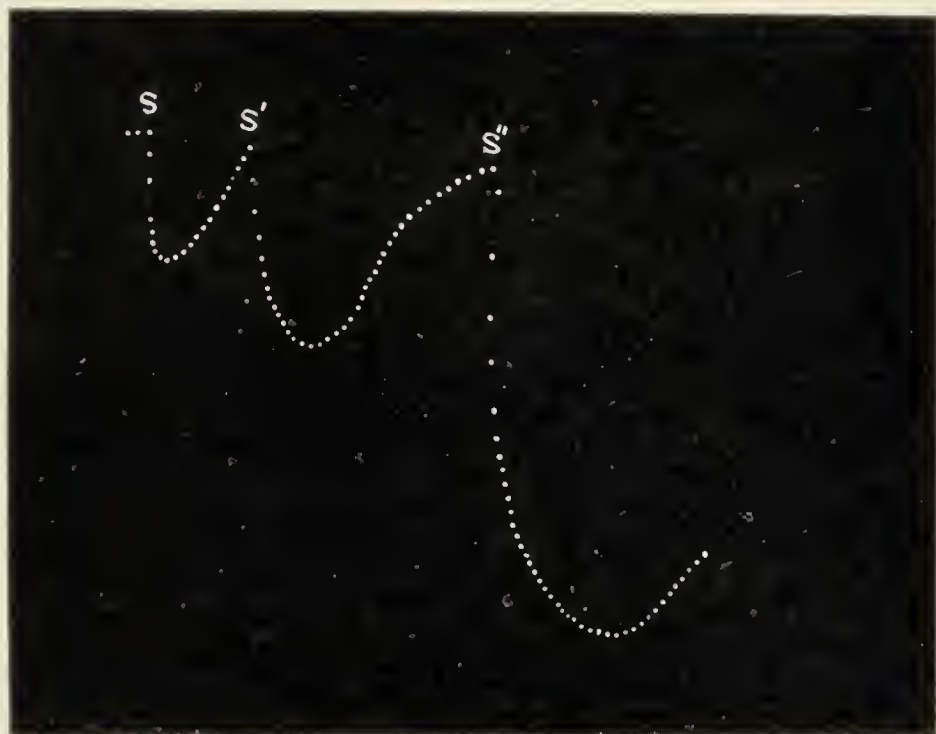

FIG. 83. Effect of increasing intensity of stimulation on diametric contraction of stem of *Impatiens* recorded by Cell-Sphygmograph.

Diametric contraction recorded as a down-curve. Note increasing contraction under increasing intensities of stimulation s , s' , s'' , with corresponding prolongation of period of recovery.

was obtained by the Cell-Sphygmograph. Stimulation by induction shock was sent along the length of the stem and the diametric contraction recorded in the usual manner. The amplitude of response is seen to undergo an increase under increasing intensity of stimulation. After the cessation

of stimulation the contracted cells become re-expanded during recovery (fig. 83). The period of recovery, as in the case of *Mimosa*, becomes protracted after strong stimulation.

EXPERIMENTS WITH THE OPTICAL SPHYGMOGRAPH

The delicacy of the method of experimentation is greatly increased by the Optical Sphygmograph, described in a later chapter, by which it is easy to produce a magnification of a million times. The optical method has the additional advantage of experimental demonstration before a large audience.

The results of the following investigations demonstrate :

- (1) The extraordinary sensitivity of the cortical tissue of even ordinary plants, this sensitivity being gauged by the responsive contraction induced by an intensity of induction-shock which is below the threshold of human perception.
- (2) The modifying effect of tonic condition on the sign of response. It will be remembered that a sub-tonic specimen of *Mimosa* responds to moderate stimulation by the abnormal positive or erectile response indicative of expansion. The tonic condition is found to be improved in consequence of external stimulation, the abnormal positive being gradually transformed into normal negative or contractile response (p. 50). Is this reaction of universal occurrence, to be discovered even in ordinary cortical tissue ?
- (3) The abolition of contractility after death caused by intense electric stimulation.

Experiment 75a. *Comparison of sensitivity of ordinary plants and of human subjects.*—The secondary coil of the induction apparatus was placed at a sufficient distance from the primary, so that the shock could not be felt by a human subject. The experiment was next so arranged that the

same sub-minimal induction-shock was passed through two human subjects and the stem of an *Antirrhinum*, all included in the same electric circuit. The electric shock which could not be perceived by the human subjects produced, nevertheless, a marked contractile response of the plant. It is a revelation to find plants reacting to stimulation which is so extraordinarily feeble.

Latent period.—In the pulvinus of *Mimosa* the rapidity of reaction, which is associated with the presence of 'active' substance, is such that the latent period is only a fraction of a second. In the ordinary cortex the latent period is relatively long, of the order of 5 to 8 seconds.

The diametric contraction under stimulation is found to be universal. It is exhibited not only by herbaceous stems, such as those of *Antirrhinum*, *Cosmos*, *Tomato*, and *Tradescantia*, but also by the woody stems of the *Rose* and other shrubs. The sensitivity depends on the species, on the season, and on the age of the plant.

Experiment 75*b*. *Modifying effect of tonic condition on the sign of response.*—A dozen similar specimens of *Antirrhinum* were taken, of which the first batch of six had recently been exposed to light, and the second batch kept in darkness for 24 hours. Under moderate electric stimulation every one of the light-exposed specimens responded by *contraction*; the second batch of subtonic specimens responded to similar stimulation by *expansion*. The abnormal positive response by expansion was gradually transformed into normal negative or contractile response under continuous stimulation. The modifying effect of tonicity on responsive reaction, observed by different methods of experimentation, is thus found to be similar in 'sensitive' and in ordinary plants.

Reference has already been made that stimulation gives rise to two reactions A and D; of these A is the more persistent as observed in the positive response of subtonic tissue already described. It occurs through a block which arrests excitation D (*cf.* Experiment 93*a*). It also lasts longer in a dying tissue than reaction D.

Experiment 75c. *Effect of intense electric stimulation.*—This causes a violent contraction which proves to be the spasm of death, for subsequent stimulation induces no further contraction. It is very curious that a testing electric shock now causes a feeble *expansion* which disappears after a while.

I describe additional results on the effects induced by direct and indirect stimulation, the record being obtained by a different method.

RESPONSE TO DIRECT AND INDIRECT STIMULATION

Experiment 76.—I carried out numerous experiments with leaves of different plants, the response being recorded



FIG. 84. Response of ordinary leaf under transmitted excitation of thermal shock (*Vinca rosea*).

by the Phytograph. When an electric shock was sent along the length of the leaf-joint, it exhibited a contractile fall, similar to that of the leaf of *Mimosa*, though the extent and the rapidity of the movement was not so great. On the cessation of stimulation the leaf underwent gradual recovery of its normal position. The leaves of *Impatiens*, *Vinca rosea*, and *Chrysanthemum coronarium* were found suitable for this demonstration.

Experiment 77. *Response to transmitted excitation.*—The leaf of *Mimosa* gives a responsive fall not only to direct

stimulation, but also to indirect stimulation of the stem. The excitation is transmitted to the pulvinus by a definite tissue which functions as the nerve. Transmitted excitation also causes a fall in a number of ordinary leaves, as shown in the record obtained with the leaf of *Vinca* (fig. 84). Such a conducting tissue occurs in a number of ordinary plants such as *Vinca*; the response of its leaf to transmitted excitation is seen in fig. 84. Stimulation in this case was produced by thermal shock applied on the stem a short distance below the leaf. A similar effect is obtained with indirect electric stimulation.

MEASUREMENT OF DIFFERENTIAL EXCITABILITY OF AN ANISOTROPIC ORGAN

Under diffuse stimulation the leaf of *Mimosa* and those of ordinary plants exhibit a movement of fall, which is attributable to the greater contraction of the more excitable lower half of the motor organ. Further insight can only be obtained by means of a method for the quantitative determination of the differential excitability of the two halves of an anisotropic motor organ. For this purpose stimulation of the same intensity is applied first on the upper and then on the lower half of the organ. The amplitudes of the two responses should give a measure of both the excitability and the contractility of the two halves of the organ. The contraction of the upper half causes an erectile movement of the leaf, shown in the record as a down-curve, while that of the lower half induces a down-movement shown as an up-curve.

The discovery of a suitable means of local stimulation presented some difficulty; it was finally found in excitation produced by the polar action of a constant current. It has been shown in Chapter IX that under a minimally effective current, excitation takes place only at kathode-make, there being no excitation at kathode-break, at anode-make, or at anode-break. Moreover, the excitation

at kathode-make under feeble current remains localised at the kathode.

Two platinum pins are thrust into the cortex of the upper and lower halves of either the pulvinus or the leaf-joint. By suitable manipulation of the reversing key R, the upper and the lower halves of the anisotropic pulvinus or of the leaf-joint are locally excited in succession by being made kathode (fig. 85).

Experiment 78. *Differential excitability of the pulvinus of Mimosa.*—On gradually increasing the polarising current,

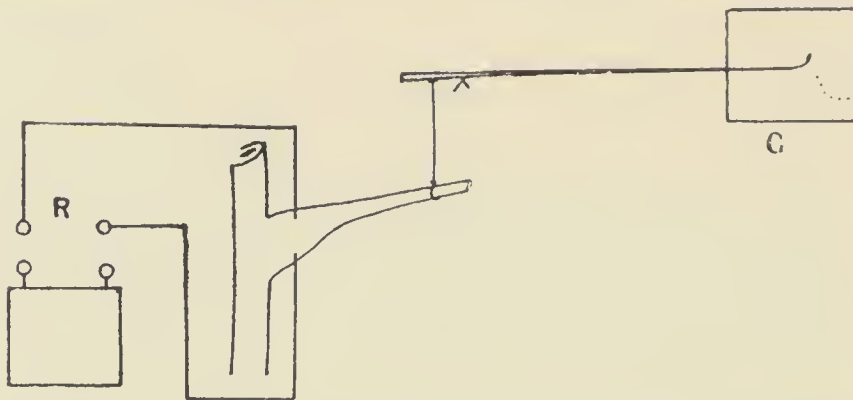

FIG. 85. Diagrammatic representation of method of local excitation of lower and upper halves of the pulvinus of *Mimosa* by polar action of electric current from a battery. R, reversing key. Record taken on smoked-glass plate c.

a point was reached when the lower half of the pulvinus alone exhibited contractile response, the upper showing no such indication. This proves that the sensitivity of the lower half is very much greater than that of the upper. When the exciting current was raised to moderate intensity (4 micro-amperes) the upper half responded under kathode stimulation by a very feeble contraction. The response was so feeble that a magnification of 30 times had to be employed in obtaining the record. By reversing the direction of the current, the lower half was next subjected to the same intensity of stimulation, the result being a very great increase in the amplitude of response. The magnification in this case had to be reduced to 7.5 times to keep the record within the plate.

There are important differences in the characteristics of the two responses. The response of the upper half is very sluggish, the latent period for the initiation of contractile response being as long as 50 seconds; the amplitude of the response is also very feeble, being about 3 mm. with magnification of 30 times. The response of the lower half exhibits a very great contrast. Associated with the presence of a large quantity of 'active substance' the contractile reaction of the lower half is extremely rapid, the response occurring almost instantaneously; the maximum contraction was also attained in the course of about 2 seconds. The amplitude of response under magnification of 7.5 times was 60 mm. (*see* fig. 22).

These results are independently supported by others described on p. 37, where it is shown that the lower half of the pulvinus of *Mimosa* is much more excitable than the lower. The response of the upper half is sluggish, and the latent period is comparatively long.

Experiment 79. *Differential excitability of the leaf-joint.*—Parallel results were obtained with the ordinary leaf-joint, of which the following results may be taken as typical. The minimal intensity of current which causes excitation of the lower half of the leaf-joint of *Chrysanthemum coronarium* was found to be ineffective for the upper. Under stronger current of 18 micro-amperes a feeble contraction was produced in the upper half, the contraction of the lower being thirty times greater.

RESPONSE OF THE PETIOLE

Experiment 80.—A detached leaf of Sunflower, with the cut end of the petiole wrapped in moist cloth, was held on a stand in a horizontal position. The leaf was attached to a recording-lever, and the response to an electric shock sent through the length of the petiole was recorded in the usual manner. The petiole responded by a down-movement which, though less pronounced than that of a pulvinus,

was very definite. This demonstration can be made very easily with the Optical Lever. The comparatively feeble movement of petiolar response is due to the relatively small mass of the cortex as compared with that of the woody tissue which offers resistance to the movement. Since the petiole responds like the pulvinus, it may be regarded as an elongated pulvinoid.

CONTRACTILE RESPONSE OF RADIAL ORGANS

In all anisotropic organs diffuse stimulation induces a marked responsive down-movement which may be described as one-sided or dorsi-ventral, whereas radial organs exhibit no such movement. Is the radial organ, then, non-contractile and insensitive in spite of the fact already demonstrated that cortical tissues undergo contraction on stimulation? I will show that, in spite of appearances to the contrary, a radial organ such as a young stem does undergo contraction which can be demonstrated (1) under diffuse and (2) under unilateral stimulation.

It should be remembered that a radial organ is almost equally excitable all round, so that the contractile movement of one side is counteracted by that of the diametrically opposite side. Hence diffuse stimulation does not cause a response of the stem by a lateral movement or bending to one side or the other. Nevertheless a responsive movement can be demonstrated of the nature of a longitudinal contraction or shortening of the length of the organ.

Experiment 81. *Longitudinal contraction of radial organ under diffuse stimulation.*—This can be clearly demonstrated under moderately high magnification of about a thousand times. As an illustrative example I will describe the response of the flower-stalk of *Crinum*. The specimen was growing at a slow rate, as shown in the record, where the growth-elongation is represented by the down-curve. An electric shock of moderate intensity caused the growth-elongation to be suddenly converted into longitudinal con-

traction, shown by the up-curve. The maximum contraction was attained in the course of 4 minutes; on the cessation of stimulus the organ exhibited recovery, the original length being regained 11 minutes after the reception of the shock (fig. 86). Repeated stimulations gave successive responses which were uniform. The response of a growing organ is thus essentially similar to that of a pulvinated organ. When the stimulus is feeble the incipient contraction is shown by a retardation of the normal rate of growth. Even when the growth has come to a state of standstill the tissue still exhibits contraction under stimulus. Contractility only disappears when the tissue is very old.

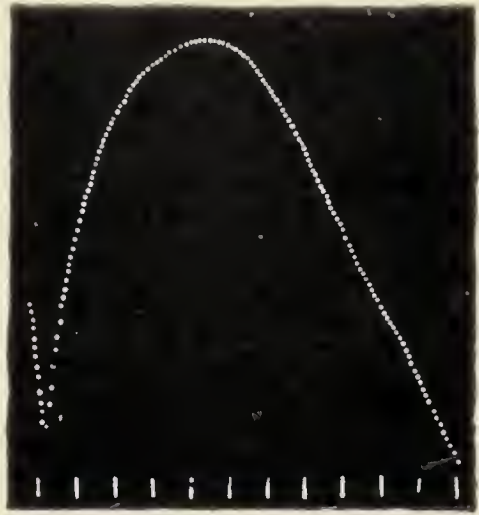

FIG. 86. Longitudinal contraction of radial growing organ under electric shock (*Crinum*). Vertical lines below indicate intervals of 1 minute. (Magnification 1000 times.) Elongation shown by down-curve, contraction by up-curve.

RESPONSE OF THE STEM BY BENDING UNDER UNILATERAL STIMULATION

The pulvinus of *Mimosa* responds by bending in one direction or the other when the upper or the lower half is subjected to local stimulation. The responsive contraction is manifested by the induced concavity of the stimulated side. Does an ordinary stem exhibit similar response by bending, the stimulated side becoming concave?

The radial stem cannot, for reasons already given, respond to diffuse stimulation by bending to one side. In order to obtain bending or curvature, it is essential that only one side of the organ should be subjected to local stimulation.

Experiment 82. *Bending of the stem under unilateral stimulation.*—Local unilateral stimulation was effected by means of a constant current, as already described. By means of a pin thrust into the cortex, a minimally effective electric current was applied for a short time on the right flank of the stem of a young Bean-plant, which was made the kathode, the anode being at a distant indifferent point on the leaf (fig. 87). Local stimulation of the right flank of the organ

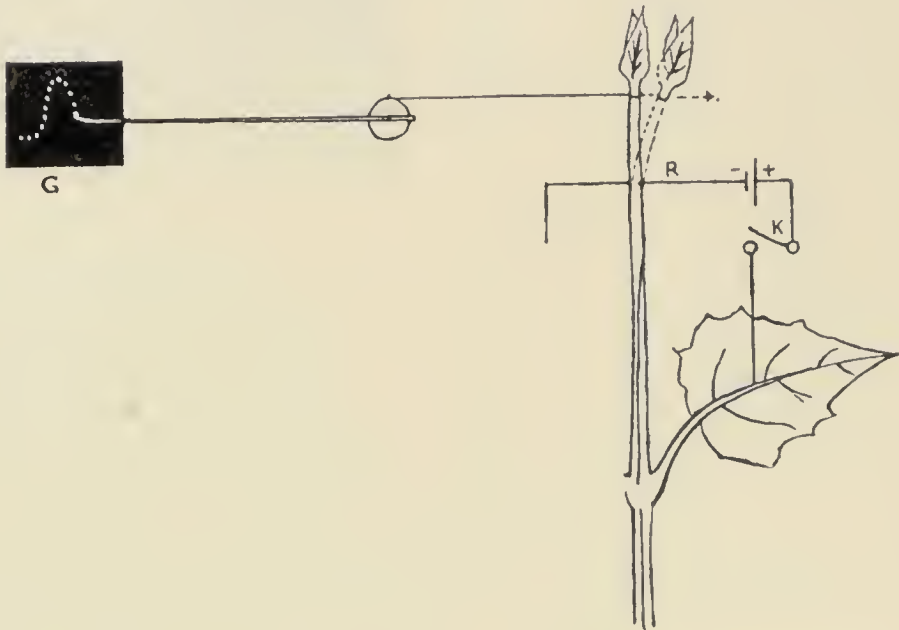

FIG. 87. Diagram showing connexions for studying the unilateral action of polar current.

K, key ; R, right flank of the stem which becomes concave on local stimulation. Parallel effect induced on the left flank. G, smoked-glass plate (*Phaseolus*).

induced at kathode-make a contraction and concavity of that side, as evidenced by the response inscribed by the recording-lever attached to the upper end of the stem. The latent period was 20 seconds ; after the attainment of maximum bending, there was recovery on the cessation of stimulation (fig. 88). When the stimulus was transferred to the left flank of the stem the movement of response became reversed by the induced contraction and concavity of that side. The responses of the right and left flanks were

essentially similar, showing that the contractility of the cortex on opposite sides of the stem is practically the same. This demonstration is of importance in the explanation of



FIG. 88. Response of the stem of *Phaseolus* to unilateral stimulation by polar action of electric current. Cessation of stimulation, at arrow within circle, is followed by recovery.

tropic curvature in plants under various modes of unilateral stimulation.

Other plants, such as *Balsam*, *Helianthus*, *Hibiscus*, and *Vinca*, gave similar results.

INDUCTION OF PHYSIOLOGICAL ANISOTROPY IN RADIAL ORGANS

An intermediate instance to fill up the gap between radial and pronouncedly anisotropic organs, is the transient anisotropy which can be induced in a radial organ. When a radial stem is held horizontal so as to be subjected to the stimulus of gravity, there is at first no immediate induction of physiological differentiation, as indicated by the absence of unilateral response to diffuse stimulation. But after a while the stem exhibits a geotropic curvature, the upper side becoming contracted and concave, while the lower side becomes expanded and convex. This is attended by induced physiological anisotropy, as demonstrated by the following experiments.

Experiment 83. *Response of geotropically curved organ.*—When the upwardly curved stem, still held in its original position, is subjected to diffuse electric stimulation, the response is a down-movement (fig. 89, *a*). The organ, originally isotropic, having become anisotropic, the expanded and convex lower side has become the more excitable. The upper side, being already contracted, is less capable of exhibiting any further contraction.

This induction of physiological anisotropy is, however, temporary, unlike the permanent anisotropy of dorsi-ventral organs. The induced physiological anisotropy can be made

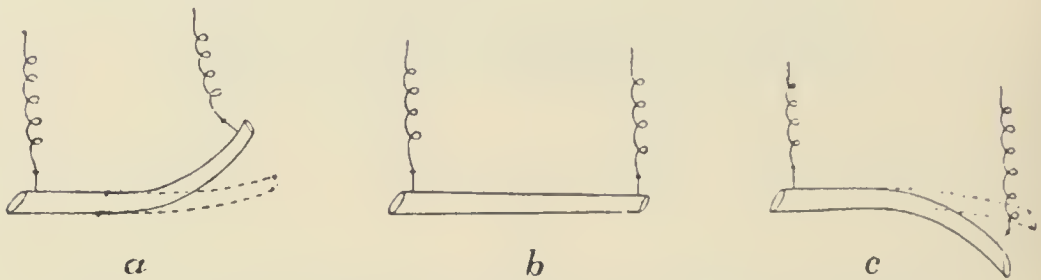

FIG. 89. Diagrammatic representation of responsive movements of geotropically curved organs under diffuse electric stimulation.

c, geotropically curved stem held inverted. Response by up-movement shown in dotted outline. *b*, no response after disappearance of anisotropy; *a*, response by down-movement. (Illustrations to be followed from right to left.)

to disappear, or even to undergo reversal, by holding the curved organ in an inverted position as in fig. 89, *c*, the convex and more excitable side being uppermost.

Experiment 84.—The stem then exhibited the following changes under geotropic action: it became straight like *b*, and, after a further interval, the curvature became reversed upwards as in *a* (fig. 89).

Experiment 85. *Response of curved organ held in inverted position.*—Under diffuse electric stimulation the greater contraction of the more excitable convex upper side gave rise to an up-response (fig. 89, *c*); stronger stimulation gave rise to a response of greater amplitude. The maximum contraction was attained in the course of about 2 minutes, and on

the cessation of stimulus the recovery became completed in about 15 minutes (fig. 90, *c*).

Experiment 86. *Response on disappearance of anisotropy*.—When the organ became straight (see fig. 89, *b*), diffuse electric stimulation induced no responsive movement either up or down (fig. 90, *b*). The anisotropy previously induced had thus disappeared at this particular phase.

Experiment 87. *Response on reversal of anisotropy*.—After a further interval, as already stated, the original convex upper side became concave and the lower side convex

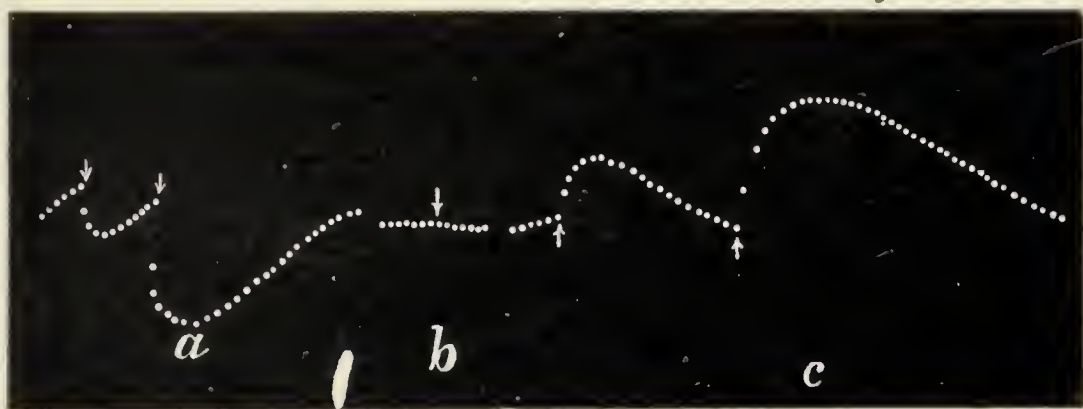

FIG. 90. Response of geotropically curved organ under diffuse electric stimulation, at three phases of geotropic curvature.

c, response by an up-movement in an up-curved organ held inverted. The two records are for feeble and moderate stimulation. *b*, no response after disappearance of anisotropy. *a*, response of up-curved organ by down-movement.

as in fig. 89, *a*. Diffuse stimulation now caused a down-response by the greater contraction of the lower convex side of the organ (fig. 90, *a*). The changing physiological differentiation in an originally radial organ is thus manifested by a definite sequence of transformation from an up-response through intermediated zero to a down-response.

THE CELLULAR MECHANISM

Returning to the response of the cortical cells in the pulvinus or in the stem under stimulation (*cf.* Experiments 75, 76), it has been shown that this can be detected and

recorded by the Sphygmograph or by the Phytograph. On stimulation there is a sudden expulsion of sap from the contracted cells; on the cessation of stimulation, recovery takes place by absorption of sap and re-expansion of the contracted cells.

These characteristic responses, indicative of contraction or expansion due to loss or supply of sap, occur in all the different organs; in the pulvinus, in the leaf-joint, and in the stem. There are various ways in which the withdrawal or supply of water can be effected, and the study of the characteristic responses of different organs gives a clearer and more comprehensive insight into the cellular mechanism. In place of the sudden removal of sap from the cortical cells on stimulation, a slower withdrawal can be effected by drought or by plasmolysis. The increasing shrinkage or contraction due to loss of water from the cortical cells can be easily demonstrated by the phytographic record of the responsive fall of the leaf of *Mimosa* or of any ordinary plant. Supply of water by irrigation gives rise, on the other hand, to expansion of the cortical cells, as shown by the consequent erectile response of the leaf.

RESPONSE OF LEAF OF MIMOSA TO SUPPLY OR LOSS OF WATER

Experiment 88.—A young *Mimosa* plant, carefully transplanted with the root embedded in soil, was placed in a linen bag. The specimen was securely held by a clamp and one of the leaves attached to the recorder. The plant was in a state of drought; a vessel full of water was now raised from below at the moment marked by vertical arrow so that the linen bag containing the roots was in water. This caused an erectile movement of the leaf within 10 seconds of the application of water (fig. 91); this must have been due to the ascent of sap, which entering the pulvinus caused an expansion and the up-movement of the leaf. In order to ascertain the effect of withdrawal of water, a quick change

was made at the horizontal arrow by substituting a 5 per cent. solution of KNO_3 for the water of the vessel in which the roots were immersed. The effect of plasmolysis was made evident not only by the arrest of the erectile movement,



FIG. 91. Response of the *Mimosa pulvinus* to irrigation and to withdrawal of water.

Increased turgor by application of water at point marked with vertical arrow induced erectile movement. Diminution of turgor by application of KNO_3 solution at the point marked with the horizontal arrow, brought about the fall of the leaf. Successive dots at intervals of 10 seconds. (The down-curve represents up-movement and *vice versa*.)

but by a reversed movement of fall of the leaf, which occurred in the course of 40 seconds. In order to demonstrate the universality of the phenomenon I repeated the experiment with an ordinary plant (*Impatiens*).

RESPONSE OF ORDINARY LEAF TO DROUGHT AND IRRIGATION

Experiment 89.—The cut end of a shoot of *Impatiens* was placed in cold water, the leaf soon attaining its normal outspread position. The record of this state of turgor-balance is seen in the horizontal curve (fig. 92). Application of warm water W at the cut end of the stem caused an

erectile response of the leaf ; this must have been due to the enhancement of the rate of ascent of sap caused by the application of warm water, with the result that excess of water was forced into the leaf-joint. It may be stated here, in anticipation of what will be described in greater detail in a



FIG. 92. Response of leaf-joint of *Impatiens* to alternate supply, withdrawal, and renewed supply of water.

Warm water applied at *w* induced erectile response, which raised leaf above normal position ; plasmolysis by KNO_3 caused a down-response, and reapplication of warm water at arrow within circle induced once more the erection of the leaf. (In this figure, the up-movement is exhibited by an up-curve, the fall of the leaf by a down-curve.)

subsequent chapter, that the rate of ascent of sap is modified by physiological agents, warmth causing an enhancement, while cold causes a depression of the rate.

While the leaf was performing the erectile movement under the action of warm water, KNO_3 solution was substituted at the cut end of the stem. Plasmolysis now caused

a rapid down-movement, indicative of contraction. In order to demonstrate the unfailing efficiency of the cellular mechanism, fresh warm water was substituted for the plasmolytic solution at the horizontal arrow. The ascent of sap became once more renewed and the previous response by fall was converted into one of erection, the leaf recovering its original position.

CELLULAR CONTRACTION AND EXPANSION

It has been explained that the fundamental contraction or expansion of the cortical cells can be recorded by two



FIG. 93. Response of stem, of leaf-joint, and of sensitive pulvinus of *Mimosa* to drought, irrigation, and plasmolytic withdrawal of water.

Record of : *a*, stem of *Antirrhinum* (by Cell-Sphygmograph); *b*, leaf-joint of *Impatiens* (by Phytograph); *c*, pulvinus of *Mimosa* (by Phytograph). The initial up-curve represents contraction under drought; the down-curve, expansion under irrigation; and the second up-curve, contraction under plasmolysis.

different methods: by the Phytograph or by the Sphygmograph. I reproduce a series of records obtained with the three typical organs, the stem, the leaf-joint, and the pulvinus, under similar variations. The record of the cellular contraction or expansion of the stem was obtained with the Cell-Sphygmograph; the Phytograph recorded the movement of the leaf of the ordinary plant and of that of *Mimosa*.

Taking the three records in order, the diametric contraction of the cortex of the stem under drought is shown by the up-curve at the beginning of the record (fig. 93, *a*). Under irrigation at the vertical line, the contraction is reversed into expansion exhibited by the down-curve. The application of the plasmolytic solution of KNO_3 at the horizontal arrow reversed the response once more, this time from expansion to contraction (fig. 93, *a*). The responses of the leaf-joint of the ordinary plant (fig. 93, *b*) and of the pulvinus of the sensitive plant *Mimosa* (fig. 93, *c*) under drought, irrigation, and plasmolysis, are precisely similar to those of the stem.

CELLULAR CONTRACTION UNDER STIMULATION

The withdrawal of water and contraction under either drought or plasmolysis is a relatively slow process; a



FIG. 94. Responses (*a*) of stem, (*b*) of leaf-joint, and (*c*) of pulvinus of *Mimosa* to drought, irrigation, and stimulation.

In all cases the record indicates the four successive phases: (1) up-curve, the slow contraction under drought; (2) down-curve, the expansion after irrigation; (3) up-curve, the sudden contraction after stimulation at *s*; (4) down-curve, the expansive recovery.

similar, though a far more rapid reaction, as previously stated, is produced by the action of a stimulus. The response to stimulation is, moreover, similar in the cortical tissues of the stem, in the leaf-joint, and in the sensitive pulvinus.

Experiment 90.—In the series of records given in fig. 94, drought caused diametric contraction of the stem and contractile fall of the leaf of an ordinary plant and of *Mimosa*, shown by the up-curve. Irrigation at the vertical line caused expansion of the stem and erection of the leaf, recorded as a down-curve. Stimulus applied at S produced in all cases a contractile response (up-curve) which was practically instantaneous and which was far more intense than the contraction induced under drought. Owing to the excessively rapid rate of contraction of the pulvinus of *Mimosa* the dot-record is prolonged into a dash during contraction. Recovery occurred in all cases, the expansive movement of recovery being shown by the down-curve.

SUMMARY

The sensitiveness of the cortex of ordinary plants is exceptionally high, response by contraction occurring under an intensity of stimulation which is below the threshold of human perception.

Diametric contraction under stimulation is exhibited not only by herbaceous but also by woody stems.

In the condition of subtonicity the response is abnormal positive, gradually converted into normal negative under continuous stimulation. The modifying influence of tonicity is similar in 'sensitive' and in ordinary plants.

Contractility disappears after death caused by intense electric stimulation.

The cortical tissue is continuous in the stem, in the pulvinate or non-pulvinate leaf-joint, and in the petiole. The movements of these organs under changing conditions are due to responsive expansion or contraction of the cortical cells.

The response of dorsi-ventral organs to stimulation is a down-movement due to the greater contraction of the lower half of the organ. The leaf-joint of ordinary plants,

as also the petiole, responds like the pulvinus of *Mimosa*, the difference being one of degree and not of kind.

The differential excitability of the two halves of a dorso-ventral organ has been determined by their response to local stimulation due to the polar action of a constant current. The sensitivity and contractility of the upper half are practically negligible compared with those of the lower half.

Radial organs, such as young stems, are also sensitive and react to diffuse stimulation by a shortening of their length.

A radial organ subjected to the stimulus of gravity gradually becomes curved. The organ originally isotropic is now anisotropic, the convex side being the more excitable. Diffuse stimulation causes response by the contraction of the more excitable side of the curved organ.

The pulvinus of *Mimosa* responds to local stimulation by bending, the stimulated side exhibiting a concave curvature; stimulation of the upper half of the pulvinus induces an up-movement, that of the lower half, a down-movement.

A young radial stem exhibits similar contraction and bending on unilateral application of stimulus, the stimulated side becoming concave.

The cellular mechanism functions similarly in every part of the cortical system, not only in sensitive but also in ordinary plants. Withdrawal of water under drought or by plasmolysis induces similar shrinkage or contraction in the stem and in the leaf-joint of ordinary plants as in the pulvinus of the sensitive *Mimosa*. Supply of water, on the other hand, induces expansive response in all these organs.

Further, in all cases stimulation causes sudden contraction of the cortical cells, involving rapid expulsion of sap.

CHAPTER XIII

RESPONSE BY ELECTROMOTIVE VARIATION

It has been explained in previous chapters that the supposed difference between sensitive and ordinary plants is quite arbitrary, and that any conspicuous movement of the tissue of ordinary plants is prevented by the physical restraint imposed by its connexion with the rigid wood. It was therefore necessary to apply some method independent of movement, to the study of the universal sensitiveness of plants. Accordingly I had recourse to the method of observing excitatory change by means of the concomitant variation either of electric potential or of electric resistance. In the present chapter I give and discuss the record of the response of plants as obtained by the method of electromotive variation. It is known that the state of excitation in an animal tissue can be detected by the induced electric variation, the excited point A being galvanometrically negative in relation to the unexcited point B. In regard to plants it had been thought that it is the sensitives alone that are excitable, exhibiting response to stimulus by mechanical and electric reactions. I have, however, demonstrated that not sensitive plants alone, but all plants and all their organs are excitable, the state of excitation being detected by the concomitant change of galvanometric negativity.¹

ELECTRIC RESPONSE OF *MIMOSA PUDICA*

In order to show that the mechanical and electric responses are but two different expressions of the same

Response in the Living and Non-Living, 1902.

excitatory reaction, a leaf of *Mimosa* was attached to the Optical Lever for the mechanical response ; suitable electric connexions were made at the same time with a reflecting galvanometer for the electric response. Stimulation was found to give rise to both mechanical and electric responses, which occurred practically at the same time. The electric response was due to the induced galvanometric negativity of the more excited point.

THE EXPERIMENTAL METHOD

Since the excitability of the lower half of the pulvinus is very much greater than that of the upper half, either direct or indirect stimulation induces a greater excitatory reaction of galvanometric negativity at the lower side. The electric connexions are therefore made as follows : the first contact is made with the more excitable lower half of the pulvinus, and the second with the relatively unexcitable upper half. It is still better to make the second contact with a distant indifferent point on the stem.

The electric contacts are made by thrusting fine platinum wires into the tissue. The irritation caused by the slight wound passes away in a short time. This direct contact is far better than the complicated method of electrolytic contact by means of non-polarisable electrodes, which is not only unnecessary but often harmful ; for unless great precautions are taken the zinc sulphate solution leaks, and coming in contact with the plant abolishes its excitability. The amalgamated zinc rods, moreover, are not absolutely iso-electric ; platinum wires, on the other hand, can be made iso-electric after annealing. The direct method of contact has the advantage of lowering the resistance to a minimum. The object of the non-polarisable electrodes is to reduce the counter E.M.F. caused by the passage of the current of response ; but as this current is extremely feeble there is hardly any counter E.M.F. induced by it.

A point which offered some difficulty was that of securing

uniform stimulation in successive experiments, and of increasing the intensity of stimulation in a graduated manner. This can be easily secured by the employment of electric shocks from an induction coil. The oscillatory induction shock may cause, however, a serious complication in case of leakage of the shock-current into the galvanometer. This difficulty was completely removed by the interposition of a

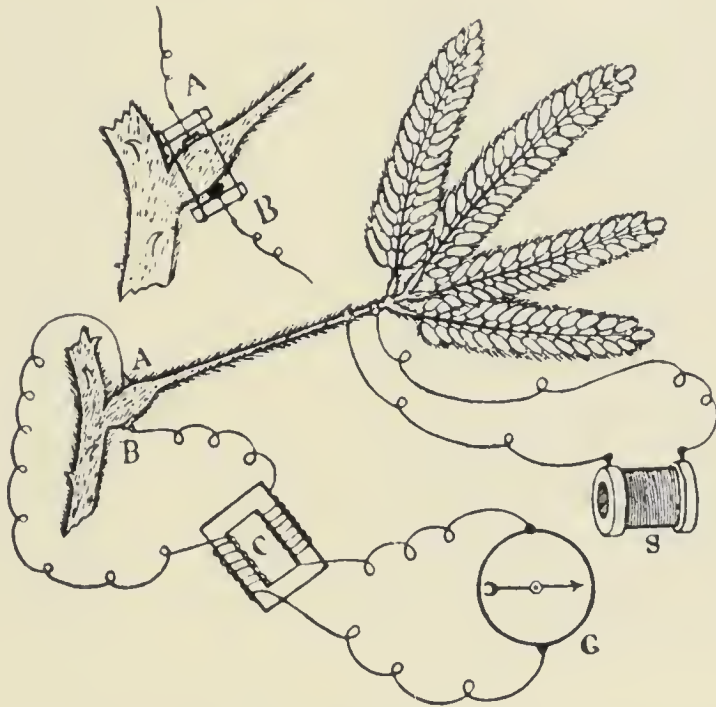

FIG. 95. Method of obtaining electric response of the pulvinus of *Mimosa*.

The choking-coil *c* prevents leakage of shock-current from secondary coil *s* into the galvanometer circuit.

magnetic choking-coil, which prevents the rapidly alternating current from entering the galvanometer circuit (fig. 95).

An important condition for obtaining the normal electric response is the maintenance of the plant in a favourable tonic condition by keeping it exposed to the diffuse light of the sky. As the galvanographic records are taken by photography, the wires attached to the plant are led to the galvanograph in a photographic room

ELECTRIC RESPONSE TO TRANSMITTED EXCITATION

Experiment 91. *Effect of moderate stimulation.*—Electric stimulation of uniform intensity was applied at regular intervals and the resulting response recorded. The photographic plate was moving at a slow rate, hence the records of response and recovery are almost superposed; it will be



FIG. 96.

FIG. 96. Uniform response of galvanometric negativity under uniform stimulations of moderate intensity (*Mimosa*).



FIG. 97.

FIG. 97. Positive electric response in *Mimosa*, under feeble stimulation.

noted that the amplitude of successive responses under uniform stimulation is the same (fig. 96). The response is that of galvanometric negativity given by the more excitable lower half of the pulvinus. This corresponds with the responsive fall of the leaf effected by the relatively greater contraction of the lower half. The electric recovery from excitation occurs in the course of 3 to 4 minutes.

Experiment 92. *Effect of feeble stimulation.*—This was found to induce a response which is of opposite sign to that of the normal, namely, of galvanometric positivity indicative of expansion instead of contraction (fig. 97). A parallel

effect was obtained in the mechanical response of *Mimosa* (*cf.* Experiment 20). If the stimulus be gradually increased from feeble to strong, the response changes from positive to normal negative at a critical intensity of stimulation. The critical value is found to depend on the tonic condition of the tissue. In a highly excitable specimen the critical point is low; it is relatively high when the tissue falls into a subtonic condition. It is therefore easy to obtain with subtonic specimens positive response under feeble stimulation, as in the following.

Experiment 93. *Positive response of subtonic tissue.*—The plant is kept in diffuse light, and the minimum intensity of stimulus which invariably gives negative response is determined. A cover is next placed over the plant so as to maintain it in darkness for about an hour, thus inducing a condition of subtonicity. Application of the stimulus which previously induced a negative response is now found to bring about a positive response. The plant is then exposed to light, to improve its tonic condition. The response is now found once more to be the normal negative.

Experiment 93a. *Unmasking of positive response by physiological block.*—Application of cold (or anaesthetics) on the petiole in the path of the impulse causes a block of the passage of excitation D, but allows the passage of impulse A (*cf.* p. 145), and thus unmasks the positive electric response.

ELECTRIC RESPONSE OF FIXED MIMOSA LEAF

Experiment 94. *Electric response of physically restrained leaf.*—It has been shown (Experiment 72) that contraction of the cells of the pulvinus occurs even when the leaf is restrained from executing the movement of fall. Similarly, the normal electric response of galvanometric negativity persists even when the leaf is held in a fixed position. The electric response is therefore due to the fundamental excitatory reaction and not to the movement of the leaf.

Experiment 95. *Electric response of water-logged pulvinus.* It has been shown that the pulvinus becomes immobile after excessive absorption of water. This may be explained on the supposition that in an over-inflated condition the expulsion of sap is prevented, thus causing an abolition of contractile response (*cf.* Experiment 34). The question now arises whether this absence of mechanical response is due to the abolition of irritability, or merely to physical restraint imposed by over-turgid tissue. In testing this question I took a pulvinus of *Mimosa* rendered mechanically irresponsive by excessive absorption of water. Stimulation gave, nevertheless, the normal response of galvanometric negativity, proving that the tissue was still irritable though unable to manifest it externally by mechanical movement.

The next point to be settled is whether or not ordinary plants also respond to stimulation by electromotive change of galvanometric negativity, proving that they also are fully excitable. After taking suitable precautions I succeeded in obtaining electromotive response of ordinary plants to stimulation caused by an induction-shock. Mechanical stimulation, however, removes all complications which might arise from the leakage of induction current into the receiving circuit. I will now describe a method of mechanical stimulation which has been rendered very efficient for the present investigation. Associated with it is the Method of Block, which will be found to have removed many experimental difficulties.

ELECTRIC RESPONSE OF ORDINARY PLANTS

The specimen A B, which may be a stem or a root, is tightly clamped at the middle by a vice V. The free ends of the specimen are held in tubes (C C') provided with three clamping jaws. A or B can be subjected to torsion by means of the handles H or H' (fig. 98). The midpoints A and B are connected with a reflecting galvanometer of

the D'Arsonval type of sufficient sensitivity to produce a deflection of 1 mm. at a distance of a metre by a current of 10^{-9} ampere.

TORSIONAL STIMULATION

If the end A be *slowly* twisted, say to the right, through 5° , the physical distortion is found to produce no electric variation; but a rapid torsion produces an electric response to the right, indicating negativity at A, the responsive current flowing from B to A through the galvanometer. It is the suddenness of the disturbance that constitutes the stimulus; the response disappears even if the specimen is kept twisted to the right. If a sudden twist to the left be now given (bringing the specimen to the original untwisted position), the responsive electric deflection to the right is produced as before. The plant is next subjected to a rapidly alternating torsion to the right and left through 5° ; the response is now found to be nearly doubled. The rapid twist and untwist, designated as torsional vibration, is thus found to be a very effective method of stimulation; the intensity of which, within limits, is found to increase with the angle of torsion. The amplitude of torsion for successive uniform stimulation is predetermined by movable stops SS', diagrammatically shown in the figure to the right. If next B be subjected to sudden to-and-fro vibration, the responsive current flows in the opposite direction, B becoming negative (fig. 98).

Advantage of the Method of Block.—The method employed in obtaining electric response in animal tissue is to render one of the two contacts, say B, insensitive by injury, the injured point being negative. Diffuse stimulation, inducing negativity at the uninjured A, causes a negative variation of the current of injury. Then the current of injury gradually subsides, with the result of disappearance of response by negative variation. By the method of injury, one end is made initially abnormal; whereas by the method of block,

on the other hand, the tissue throughout is in a normal condition. There is, again, the further advantage that any set of results obtained by stimulating A can be verified by

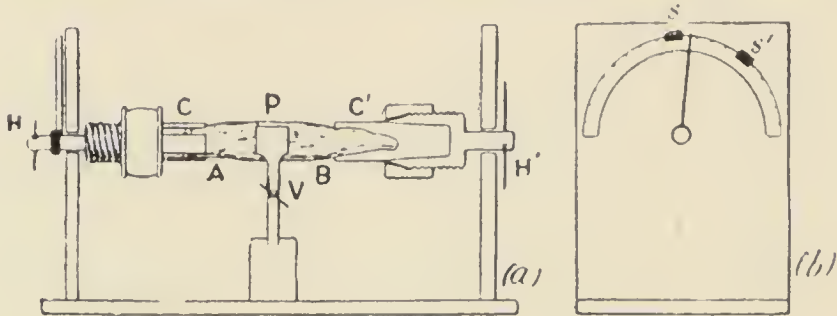

FIG. 98. The Torsional Stimulator.

Plant P is securely held by a vice v which serves as a block. The two ends are clamped by holders c c'. By means of handles H H', torsional vibration may be imparted to either the end A or the end B of the plant. The end view (b) shows how the amplitude of torsion is predetermined by means of movable stops s s'.

corroborative reversal experiments by stimulating B. The excitation of A and B remains localised, the transmission of excitation from one end to the other being prevented by the interposed mechanical block.

ADDITIVE EFFECT OF STIMULATION

Experiment 96.—The amplitude of the response can, as already stated, be increased by increasing the angle of the torsional vibration. This is, however, liable to produce fatigue; but it is possible to obtain enlarged response by the additive effect of repeated feeble stimulations, each of which is individually ineffective. Thus a single stimulation by a torsion of 3° produced little or no effect; but when it was repeated 30 times it evoked a large response, the amplitude of which was 40 mm. The advantage of this is that with small angles there is little physical distortion produced in the tissue. The mechanical stimulation is effected by automatic means; one end of the plant-organ is fixed in a torsional clamp, and rapid alternating torsions are given to that end by means of a clockwork (*see* fig. III). Suitable

adjustments are provided for regulating the angle of torsion. After the clock is fully wound a press-button releases it, with the result that a definite number of torsional vibrations are produced in rapid succession.

APPARATUS AND PLANT-CHAMBER

The complete torsional apparatus and the plant-chamber are shown in fig. 99. Moistened cotton threads

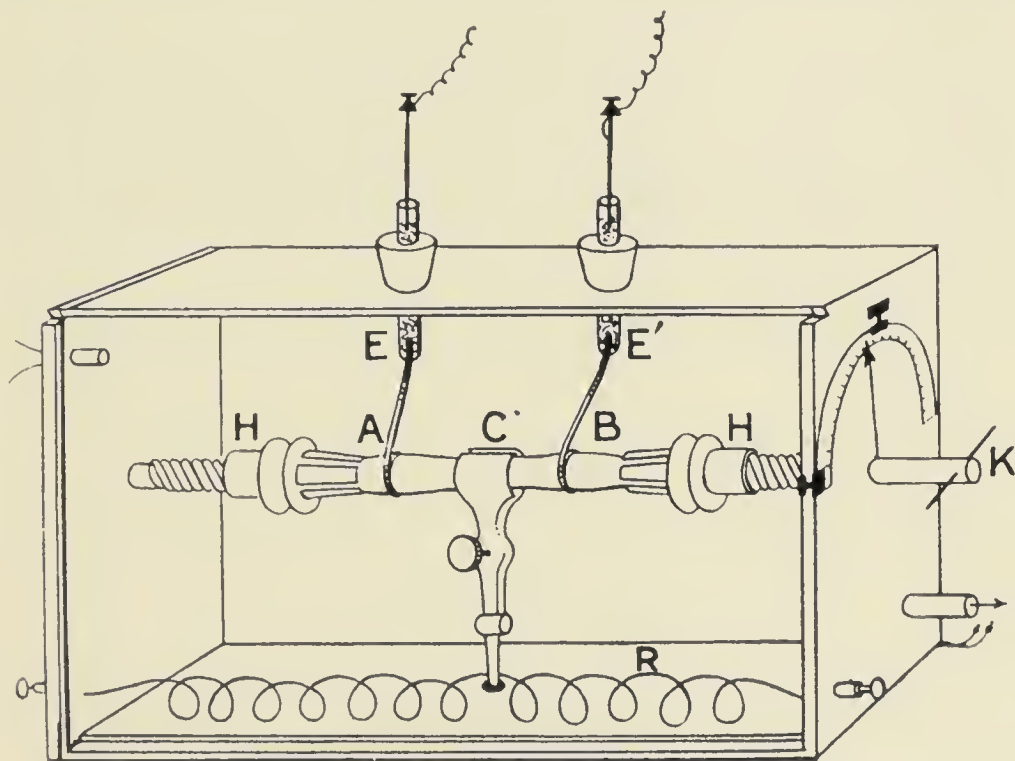

FIG. 99. The Plant-Chamber.

Amplitude of torsion which determines the intensity of stimulus is measured by the graduated circle seen to the right. The plant is clamped in the middle at *c*, which acts as a block. Temperature is regulated by the electric heating coil *R*. Vapour or gas can be blown into the chamber through the side tube.

in connexion with non-polarisable electrodes make secure electric contacts with *A* and *B*. It is, however, preferable, as previously explained, to make direct platinum contacts with the two points. The air in the chamber is kept in a humid condition by means of moistened blotting-paper.

For experimenting on the effects of temperature there is an electric heating coil, R, inside the chamber, for raising the temperature to any desired degree. For the study of the effects of different gases on the excitability of the plant there are inlet and outlet tubes which enable a stream of the required gas or vapour to be circulated through the chamber.

Response Recorder.—I devised the following simple form of recorder for obtaining tracings of the electric response. The curves are obtained directly by tracing the excursion

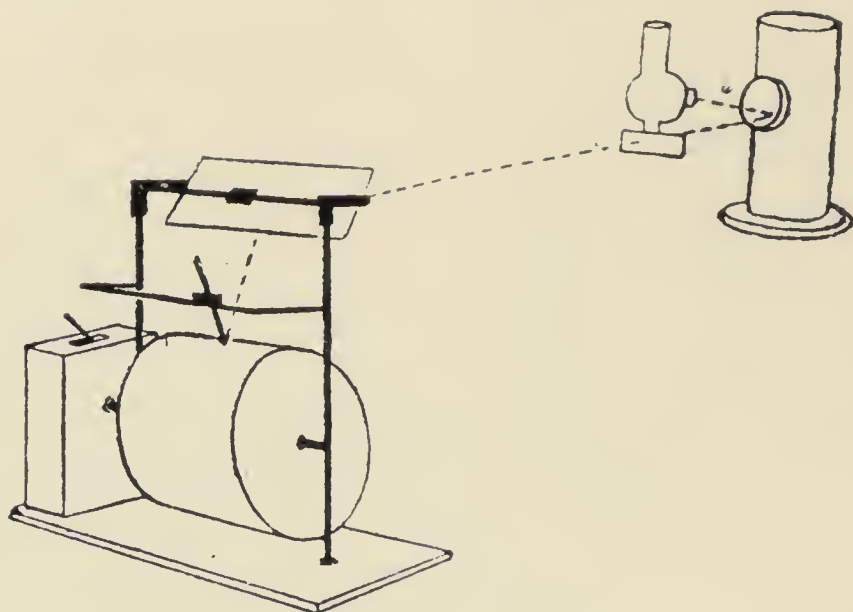

FIG. 100. Response Recorder.

Spot of light reflected from galvanometer is thrown on revolving drum and followed with pen.

of the galvanometer spot of light thrown down on the revolving drum by a fixed mirror inclined at 45° . The responsive deflection of the galvanometer is followed by moving the carrier which holds the recording-pen (fig. 100). The return of the spot to the original position is similarly followed, and the complete curve exhibits response and recovery. The ordinate represents the electromotive variation, and the abscissa the time. Photographic record of response can be obtained by wrapping a sensitive film round the drum. The following photographic records attest the reliability of the experimental method.

EFFECT OF INCREASING INTENSITY OF STIMULATION

Experiment 97.—The stimuli of torsional vibration were increased from 2.5° to 12.5° by steps of 2.5° at a time.

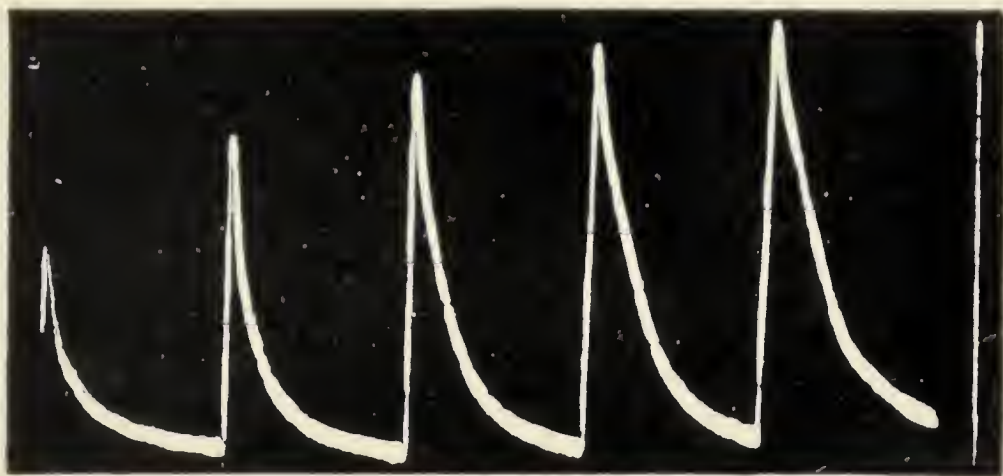

FIG. 101. Increasing amplitude of electric response to increasing torsional stimulation; the vertical line to the right represents 0.1 volt.

Stimulation applied at intervals of 3 minutes (Cauliflower-stalk).

Fig. 101 shows that the intensity of response increases and approaches a limit. The following table gives the absolute values of the responsive electromotive variations.

TABLE XI.—SHOWING THE INCREASED ELECTROMOTIVE VARIATION INDUCED UNDER INCREASED INTENSITY OF STIMULATION.

Angle of torsion	Induced E.M.F.
2.5	·044 volt
5.0	·075 „
7.5	·090 „
10.0	·100 „
12.5	·106 „

Such electric response to mechanical stimulation is obtainable with all plants and with every plant-organ. The following table contains a list of specimens which give a fairly large electromotive response, which may sometimes be as high as 0.1 volt.

TABLE XII.—LIST OF DIFFERENT SPECIMENS AND ORGANS.

Organs	Specimens
Root	Carrot (<i>Daucus Carota</i>) Radish (<i>Raphanus sativus</i>)
Stem	Geranium (<i>Pelargonium</i>) Vine (<i>Vitis vinifera</i>) Amaranth (<i>Amaranthus</i>)
Petiole	Horse Chestnut (<i>Aesculus Hippocastanum</i>) Turnip (<i>Brassica Napus</i>) Cauliflower (<i>Brassica oleracea</i>) Celery (<i>Apium graveolens</i>) Eucharis Lily (<i>Eucharis amazonica</i>)
Peduncle	Arum Lily (<i>Richardia africana</i>)
Fruit	Egg-plant (<i>Solanum Melongena</i>)

UNIFORM RESPONSES

Experiment 98.—The responses are uniform under uniform stimulation, provided sufficient time is allowed for



FIG. 102. Uniform electric responses under torsional stimulation (Carrot).

the completion of protoplasmic recovery. The uniform electric responses obtained with Carrot are given in fig. 102.

FATIGUE

Experiment 99.—Fatigue, however, occurs under shorter periods of rest. In the first three responses (fig. 103) the stimulation was at intervals of 1 minute, by which time the recovery was complete; the successive responses are

therefore large. The rhythm of stimulation was now changed to intervals of half a minute instead of a whole, while the

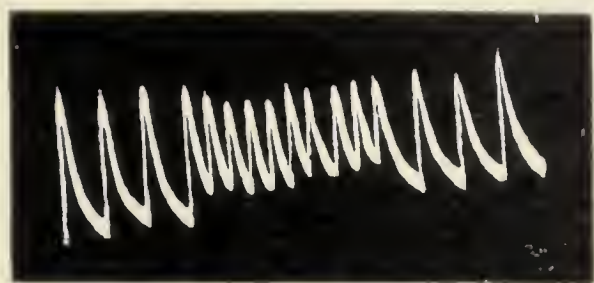

FIG. 103. Fatigue of electric response with shortened period of rest.

stimuli were maintained at the same intensity as before. The responses were then much diminished on account of fatigue. The original minute-rhythm was now restored, with the restoration of the original amplitude of response.

EFFECT OF TEMPERATURE

Experiment 100.—The electric response is reduced or abolished on lowering the temperature. The tropical

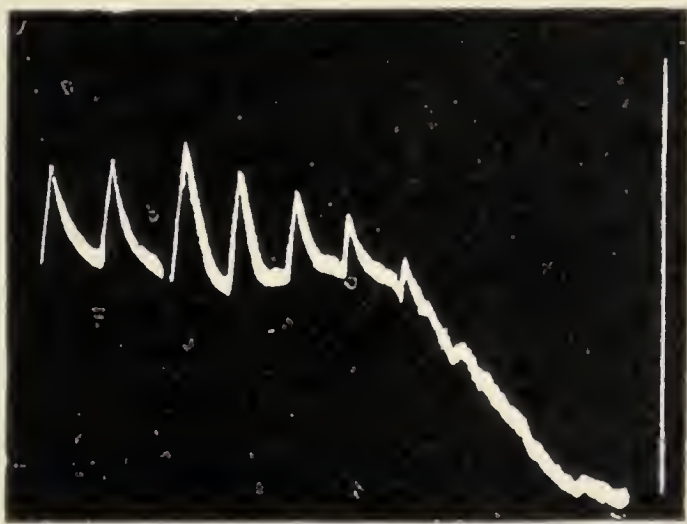

FIG. 104. Abolition of electric response by steam (Carrot).

The first two responses (left) took place at a temperature of 17° C. Steam was then admitted. At the end of 5 minutes response ceased, the Carrot was dead. The vertical line (right) represents 0.1 volt.

Eucharis Lily is particularly sensitive to the action of cold. When the temperature is lowered to 2° C. the electric

response is temporarily abolished, the excitability being restored on return to the normal temperature. The response is at its maximum at a certain optimum temperature. It is permanently abolished when the plant is exposed to too high a temperature; fig. 104 exhibits the effect of introduction of steam into the plant-chamber. There was at first a transitory augmentation of excitability. But this quickly disappeared, and response was permanently abolished with the death of the plant (fig. 104).

EFFECTS OF ANAESTHETICS AND POISONS

Experiment 101.—The mode of experimentation was first to obtain a series of normal responses to uniform stimuli



FIG. 105. Gradual abolition of electric response under Chloroform.

applied at regular intervals of time. After this, without interrupting the procedure, the anaesthetic agent, chloroform vapour, was blown into the closed chamber containing the plant. It will be seen how rapidly chloroform produced a depression culminating in abolition of response and death (fig. 105).

Various poisons were found to produce permanent abolition of response. Among the poisonous agents which abolish the electric response by killing the plant may be mentioned solutions of potassium cyanide and mercuric chloride.

SUMMARY

Plants and all their different organs are excitable and respond to stimulation by an electric reaction of galvanometric negativity.

A feeble stimulation, individually ineffective, becomes effective on repetition.

The amplitude of response, within limits, increases with the intensity of stimulation.

Uniform stimuli, applied at suitable intervals, induce uniform responses. Fatigue is induced by shortening the intervening period of rest.

The electric response of a subtonic tissue is positive. External stimulation raises the tonic level of the plant and transforms the positive to the negative.

Electric response is arrested at a minimum temperature. Rise of temperature up to an optimum enhances the excitability, as seen in the increased amplitude of response. There is a fatal temperature at which the response undergoes permanent abolition.

Vapour of chloroform in strong doses induces a rapid depression and abolition of the electric response.

Under all variations of external conditions, the records of mechanical and electric responses show similar modifications. These responses are, therefore, both expressions of one and the same protoplasmic variation.

CHAPTER XIV

ELECTROMOTIVE RESPONSE UNDER PHOTIC STIMULATION

THE electric response of plants described in the previous chapter was obtained under mechanical and electric stimulation which caused excitation of the tissues as a whole. The stimulus of light impinging from outside has to traverse the epidermis before it can reach the living protoplasm in the interior. In my previous works it has been shown that the normal response of leaves to light is one of galvanometric negativity, as it is under other modes of stimulation. Some observers have, however, obtained in green leaves a response of galvanometric positivity, from which the conclusion has been drawn that the response to light is of an opposite character to that induced by other modes of stimulation.

I can, however, show that the normal response of the leaf to photic stimulation is that of galvanometric negativity, the positive reaction being manifested only under certain specific conditions. These are, first, the age of the specimen ; a highly excitable young specimen gives normal negative electric response ; but the excitability is greatly enfeebled when the tissue is either too young or too old. In these circumstances the response tends to become the abnormal positive.

There is another complicating factor : in vigorous green leaves the negative excitatory response is brought about by the D-reaction associated with dissimilation and breakdown of complex chemical compounds. Light, however, also causes in green leaves the opposite assimilatory process A (photosynthesis) indicated by a positive electric response. The resultant response is therefore $A - D$ (*cf.* p. 50).

NORMAL RESPONSE TO LIGHT

For obtaining the response, a vigorous leaf is taken and pinned on a block of paraffined wood. Two pieces of thin muslin in connexion with non-polarisable electrodes are spread over two areas of the leaf A and B; when these pieces of muslin are moistened with normal saline solution, they become practically transparent.

Experiment 102.—When light from an arc-lamp is thrown on A, that area becomes galvanometrically negative and

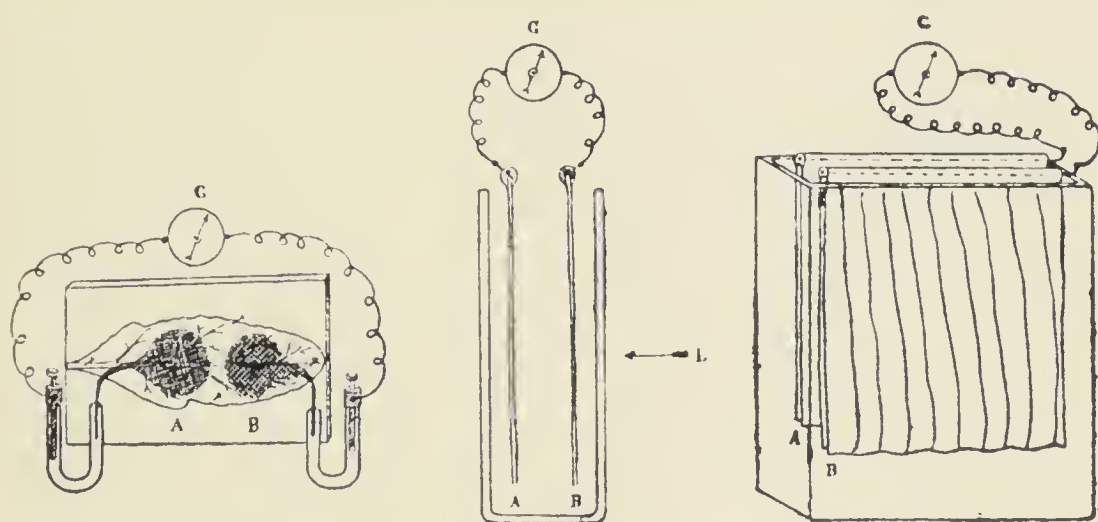

FIG. 106. Arrangement for obtaining electric response of the leaf to light.

The two figures to the right show the photo-electric cell.

the direction of the responsive current is in the direction of G A B. Light thrown on B (A being shaded) causes a response in the opposite direction (left illustration, fig. 106).

Experiment 103.—The fact that the electromotive response under light is the same as that under any other form of stimulation, such as the mechanical, is demonstrated as follows: the moist piece of cloth on A is rubbed against the surface of the leaf by means of a glass rod; or the leaf may be struck with a glass hammer. In both these cases A becomes galvanometrically negative, the direction of the current of response being the same as when A is stimulated by light.

THE PHOTO-ELECTRIC CELL

Having given a simple demonstration of the fundamental reaction, I now describe the photo-electric cell made of the two halves of a leaf. In the experiment described above the resistance of the circuit is very great, first, on account of the high resistance of the two non-polarisable electrodes, and secondly, because of the resistance offered by the leaf. The non-polarisable electrode, moreover, is a source of much trouble; an attempt was therefore made to discard it and employ means for diminishing the resistance of the circuit. For the following experiments I employed the leaf of *Musa sapientum*, which is divided into two longitudinal halves by a slit along the thick midrib. The two half-leaves thus obtained, measuring about 10×10 cm., are hung parallel to and separate from each other in a rectangular glass vessel filled with normal saline; the distance between the two is 3 cm. A gold wire is thrust through the length of each of the half-midribs; the wires serve as the electrodes of the photo-voltaic cell, leading to the galvanometer G. The glass vessel is placed inside a rectangular wooden chamber with hinged doors on two opposite sides, by which the two half-leaves, A and B, can be alternately exposed to light (fig. 106). When the doors are closed and A and B are in darkness, they are practically iso-electric, there being no indication of current by the galvanometer. Exposure of A to light gives rise to a difference of potential between the two half-leaves, A becoming galvanometrically negative, the resulting galvanometric deflection being in one direction. Exposure of B gives rise to a responsive deflection in the opposite direction. The two half-leaves serve as the two plates in a voltaic cell; but unlike an ordinary voltaic cell with plates of different metals, the two plates of the 'vegetable cell' are the two halves of the same leaf, the electromotive force being generated by the excitatory action of light on one of them. The advantages of this method of obtaining an electromotive response are: (1) that the

troublesome employment of non-polarisable electrodes with their high resistance is dispensed with; (2) that the area of the surface of the leaf exposed to light is considerably increased; (3) that the electric resistance of the circuit is greatly decreased, since the interposed resistance is that of normal saline about 3 cm. thick with a broad section of 100 square cm.; and (4) that alternate and opposite responses may be obtained by successive exposures of the two leaf-plates to the parallel beam of an arc-lamp, this being easily secured by turning the rectangular plant-chamber upon a revolving base.

RESPONSE OF THE LEAF TO LIGHT

Experiment 104.—The photo-voltaic cell thus constructed is stimulated by light from an arc-lamp which passes through a trough of alum-solution for the absorption of the heat-rays. Successive exposures are made for 10 seconds and records obtained on a moving photographic plate. The normal responses are uniform, exhibiting induced galvanometric negativity shown by the up-curves. On the cessation of light there is a complete recovery; in fact, the recovery shows an overshooting towards galvanometric positivity from which it returns to almost the original zero position (*see* fig. 108). The reason for this will be presently given.

EFFECT OF INCREASING QUANTITY OF LIGHT

Experiment 105.—The amplitude of response is increased with increasing intensity of light; it is also increased with longer duration of exposure. Thus, keeping the intensity constant, responses to increasing durations of light, of 5 seconds, 10 seconds, and 15 seconds, are recorded. The amplitude of response is seen to undergo an increase with the increased duration of exposure (fig. 107). But this increase does not go on indefinitely; for the continuous

action of light causes a maximum negative response, beyond which a decline sets in. There must, therefore, be an

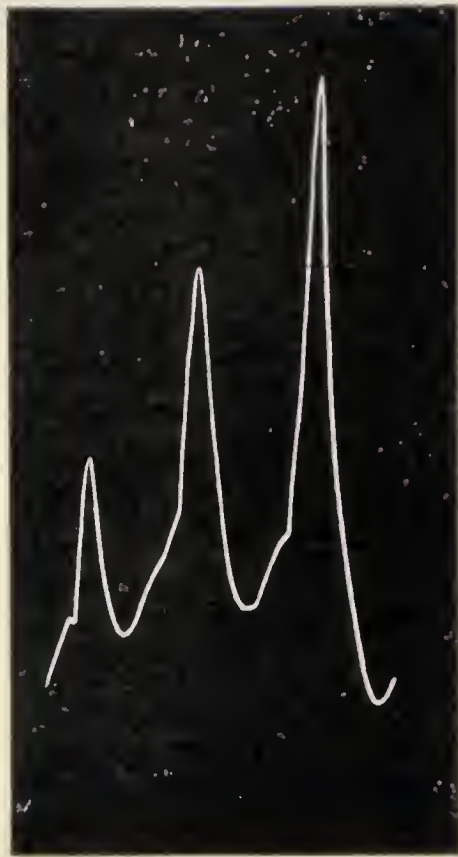

FIG. 107. Effect of increasing duration of exposure of 5, 10, and 15 seconds.

opposing element which tends to neutralise the normal excitatory D-effect.

UNMASKING OF THE A-EFFECT ON SUDDEN STOPPAGE OF LIGHT

It has been stated that the positive A-effect due to light is often masked by the D-effect. I have, however, succeeded in unmasking A by the stoppage of light. When the light is stopped, the A-effect is often found to be more persistent than the D, the result being a transient overshooting of the response in the positive direction.

Experiment 106. *Positive after-effect.*—In the records of the electric response of *Musa* to light, the up-curves indicate

galvanometric negativity during the continuance of light. On the stoppage of light the unmasking of A is seen in the positive after-effect. For the recovery does not stop at the



FIG. 108.

FIG. 108. The negative electric response of *Musa* to light, up-curve exhibiting the predominant D-reaction. Note the unmasking of A in the positive after-effect (down-curve).



FIG. 109.

FIG. 109. The 'overshooting' of the response of *Musa* in the positive direction on the cessation of light.

First half of record shows neutralisation under continuous light ; down-curve in the second half exhibits the unmasking of the positive A on stoppage of illumination.

zero base-line, but goes beyond it towards the positive direction and then returns to zero (fig. 108).

The phenomenon of 'overshooting' after neutralisation.— I have succeeded in demonstrating the A-effect by another method. Under the continuous action of light the negative

response undergoes a decline almost to neutralisation. This is due to the joint effects of fatigue and of the increasing positive reaction which neutralises the negative. On the stoppage of light, the A-effect, hitherto masked, exhibits itself by an overshooting of the response in the positive direction (fig. 109).

POSITIVE ELECTRIC RESPONSE IN HYDRILLA

The Hydrilla plant readily absorbs CO_2 from water, and the anabolic activity A is quite evident from the rapid rate of evolution of oxygen during photosynthesis. The excitatory D-process, no doubt, is also in operation, but I hoped that in very active specimens the anabolic A would be so pronounced as not to be completely masked by the catabolic D. My anticipations were fully verified, as in the following experiments.

Two middle portions of Hydrilla stems, bearing leaves, were employed as the two plates of the photo-electric cell, electric connexion with the galvanometer being made by gold wire thrust through the interior of the stems. After a suitable period of rest the normal activity of the plant was found to be restored. The photo-electric cell was filled with tank-water containing a sufficient amount of CO_2 . Alternate exposure of the two plants to sunlight (suitably reflected by a mirror) caused photosynthesis, evidenced by the evolution of oxygen. The photo-electric cell was enclosed in a dark box provided with a photographic shutter for giving the necessary exposure.

Experiment 107.—I give a record (fig. 110) of the electric response thus obtained; the duration of exposure to light was 1 minute, and a very large down-response occurred, indicating galvanometric *positivity* of the exposed plants. The electric response disappeared after recovery on the cessation of light. The record here given shows the predominant A-effect.

The responses of *Musa* and of actively assimilating Hydrilla to light are seen to exhibit characteristic differ-

ences on account of the relative predominance of the D- or the A-effect. In *Musa*, D is predominant, A being exhibited either as a positive after-effect or by the overshooting of the



FIG. 110. The positive electric response of *Hydrilla*.

response in the positive direction. In an actively assimilating *Hydrilla* plant, on the other hand, A is predominant and the resultant response is positive.

SUMMARY

The electric response to exposure to light is most conveniently obtained by the device of the photo-electric cell in which the two plates are leaves or entire plants.

The electric response of a leaf to light exhibits an algebraic summation; photic stimulation of the cell-protoplasm induces catabolism D, which is indicated by a negative electric variation: at the same time light acts upon the chloroplasts inducing anabolism A in the form of photosynthesis, associated with a positive electric variation. Generally the negative variation masks the positive: but the positive can be detected as an after-effect upon the withdrawal of light. The A-effect is also unmasked by the phenomenon of 'overshooting.'

The electric response of the actively assimilating *Hydrilla* plant is positive, indicative of the predominant anabolism A.

CHAPTER XV

RESPONSE BY VARIATION OF ELECTRIC RESISTANCE

Two independent methods have been described for the determination of physiological changes induced in the plant, namely, those of mechanical and of electromotive response. I will now describe a third method, successfully employed in my previous work, viz. that of resistance-variation.¹ This method has been considerably improved and extended for my recent investigations. The specimen plant is made the fourth arm of a Wheatstone Bridge, and the normal resistance determined. This is very high, of the order of some hundred thousands of ohms. When the tissue is subjected to stimulation its resistance undergoes variation.

The inquiry relates to the effects of mechanical, electric, and photic stimulation on the electric resistance of the tissue. I will first describe the effect of mechanical stimulation.

VARIATION OF RESISTANCE UNDER MECHANICAL STIMULATION

The stem of one of the various plants used is mounted as in the diagram (fig. III). It is clamped in the middle, and its two lengths, P and Q, form the two arms of the Wheatstone Bridge. The electric contacts with the stem are made by means of two platinum pins which are thrust into it. The ratio arms of the bridge, R and S, are made by a rheostat R S with a sliding contact. There is balance when $PS = QR$; successive completion of the battery and

¹ *Comparative Electro-Physiology* (1907), p. 540.

of the galvanometer circuits by means of a double contact-key (not shown in the figure) now causes no deflection of the galvanometer. But if the portion of the plant *P* when stimulated undergoes a diminution of resistance the fact is demonstrated by a resulting deflection, say, to the right; a deflection to the left indicates, on the other hand, an increase of the resistance of *P*.

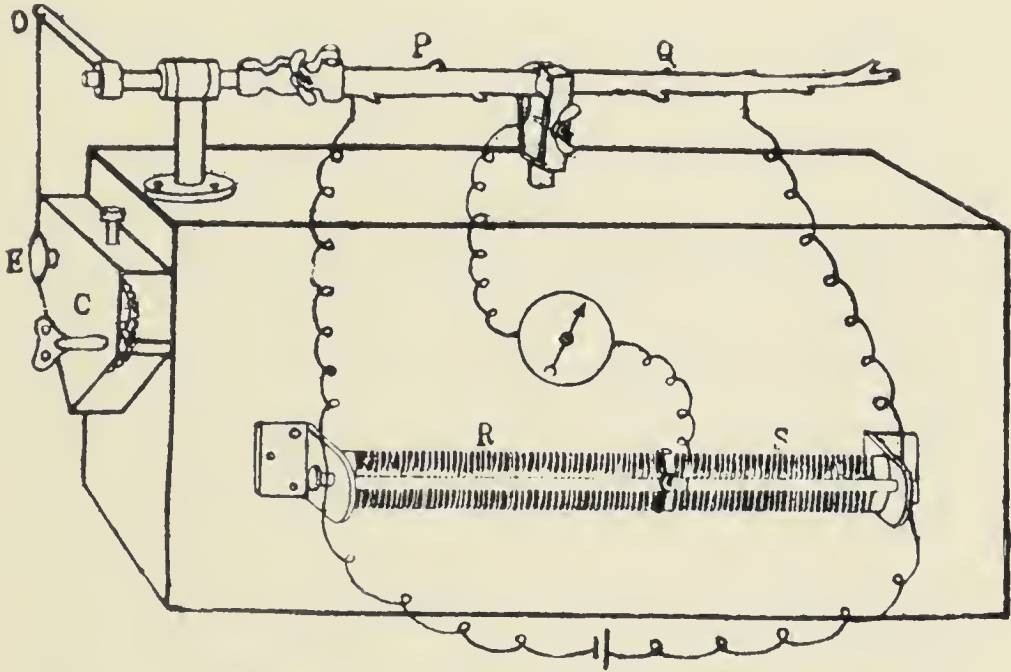

FIG. 111. Experimental method for obtaining response to mechanical stimulation by resistivity variation.

P and *Q* are lengths of plant which form two arms of the bridge, of which *P* alone is subjected to torsional vibration by means of the revolving eccentric *E*, worked by clockwork *C*. The two other arms of the bridge, *R* and *S*, are formed by the rheostat with sliding contact.

Balance is easily secured in the following manner: the sliding contact of the rheostat is at first placed in the middle position, and the resistance of *Q* is gradually diminished by moving the platinum contact inwards from the extreme right. After obtaining an approximate balance, the plant is allowed a period of rest for about 15 minutes, after which the irritation caused by the prick of the platinum wires has disappeared. Complete balance is then obtained by the careful adjustment of the sliding contact of the rheostat.

The mechanical stimulation is produced by the length of stem P being subjected to rapid torsional vibration by means of the revolving eccentric E, actuated by the clockwork C. The clockwork is released by pressing a button which results in 20 rapid torsional vibrations being imparted to P.

UNIFORM RESPONSES OF DIMINUTION OF RESISTANCE

Experiment 108.—A series of uniform responses to a constant stimulus applied at intervals of 10 minutes is given

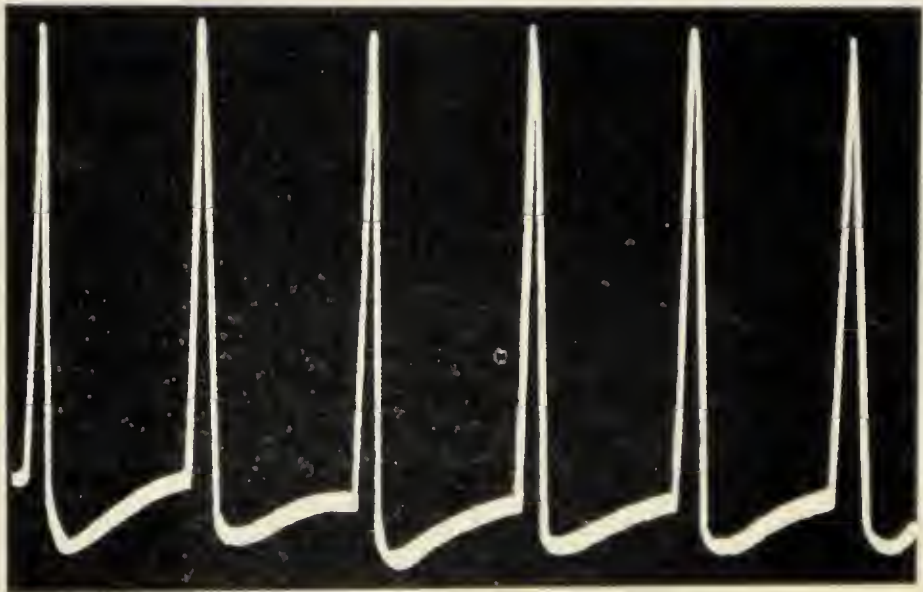

FIG. 112. Record showing uniform responses to mechanical stimulation by diminution of resistance (up-curve) followed by recovery (down-curve) (*Calotropis gigantea*).

in fig. 112, the response (up-curve) indicating a *diminution of resistance*. The experimental specimen was a stem of *Calotropis gigantea*. Other plants also give similar results, though some are more sensitive than others. The sensitiveness is further modified by age, by season, and by the physiological condition of the tissue. The responsive variation under stimulus may sometimes amount to 10 per cent. of the normal resistance.

EFFECT OF CHLOROFORM

The physiological character of the response is demonstrated by the action of anaesthetics.

Experiment 109.—The effect of chloroform in inducing depression of response is seen in fig. 113. The first record shows the normal response under stimulation ; chloroform

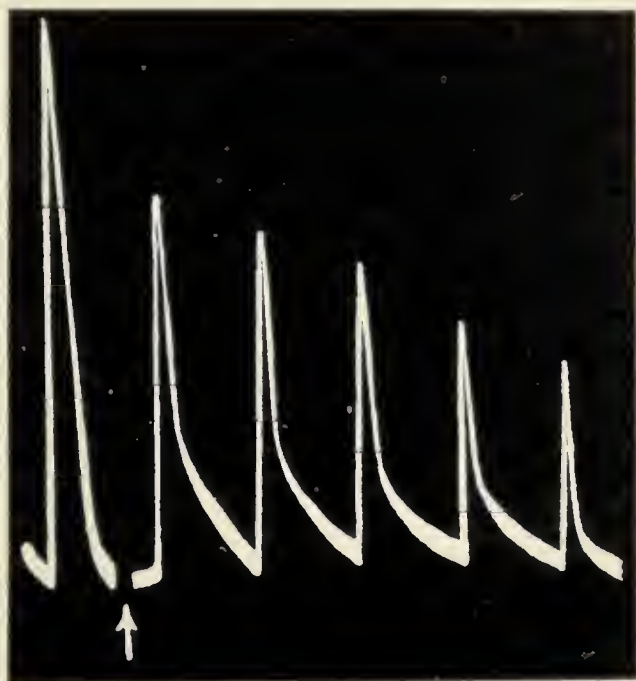

FIG. 113. Effect of Chloroform in inducing depression of response by variation of resistance.

was applied at the point marked with an arrow, the subsequent responses being obtained at intervals of 10 minutes. The amplitude of response is seen to undergo a rapid diminution under the continued action of the anaesthetic. Under a moderate dose of the anaesthetic the preliminary effect is an enhancement of response, followed by depression.

EFFECT OF ELECTRIC STIMULATION

The electric method of stimulation has the great advantage of easy graduation of its intensity. The experimental

method is illustrated by fig. 114; two platinum pins are thrust about 5 cm. apart into the stem of a plant growing in a pot. Records are taken of the variation of resistance induced by stimulation in this particular portion of the

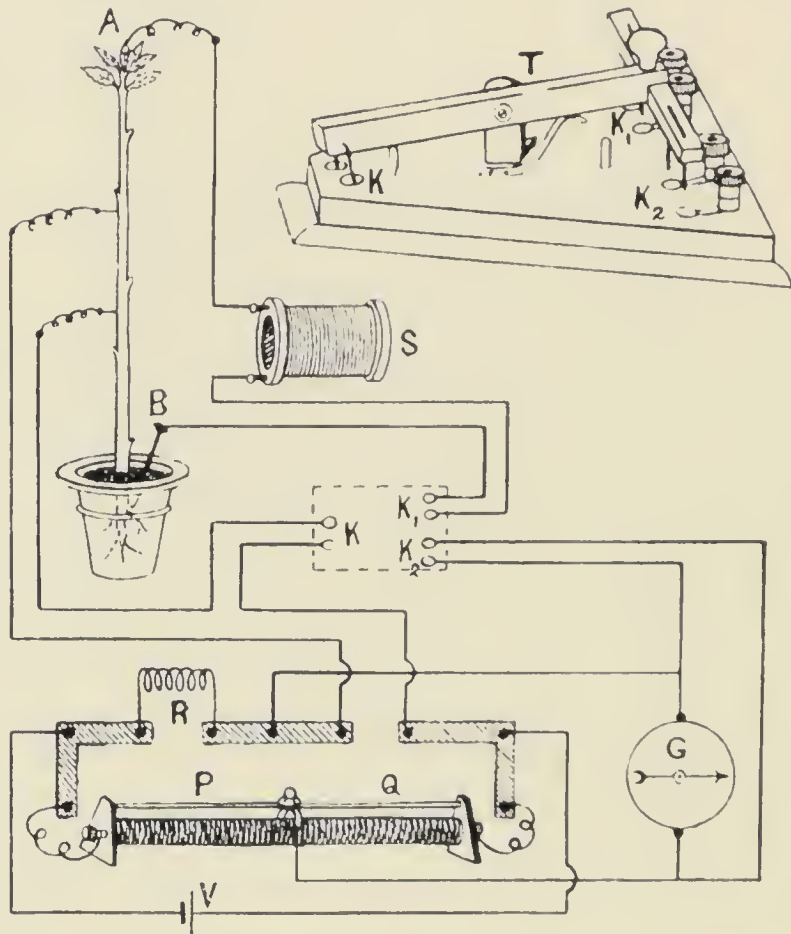

FIG. 114. Method of resistance-variation in response to stimulation. Pressure on the tilting key $K T$ causes stimulation of the plant by induction-shock from coil S , the galvanometer circuit being cut off at the same time (*see text*).

The two ratio arms of the bridge are marked $P Q$.

plant, which forms the fourth arm of the Wheatstone Bridge. An electric shock from an induction-coil is passed through the length of the plant, between the apex and the root, thus causing uniform stimulation of the intermediate portion of the plant.

The electric stimulation is direct, so the prevention of the leakage of shock-current into the galvanometer circuit

presents certain difficulties. These are, however, completely removed by cutting off the galvanometer connexion with the plant during the passage of the induction-shock. The shock-circuit S must, moreover, be cut off from the plant during the determination of the resistance and its induced variation ; otherwise the coil S would act as a shunt.

The method of procedure is as follows : the key K is closed and K_1 and K_2 opened. Exact balance is obtained by the sliding contact by which the ratio of the two arms of the bridge P and Q can be varied. The balanced condition is shown when the galvanometer deflection is reduced to zero. The plant is then cut off from the galvanometer and put into the shock-circuit ; this is done by opening the key K and closing K_1 ; K_2 is simultaneously closed so as to short-circuit the galvanometer. The electric shock is thus allowed to pass through the plant for half a second, after which K_1 and K_2 are opened and K closed. The variation of resistance induced by stimulation causes an upset of the previous balance of resistance, with a resulting deflection of the galvanometer spot of light.

In practice, the successive manipulations of making, breaking, and remaking the connexions are performed almost automatically by a momentary pressure on the tilting key T, and release of the pressure. The relative position of the three keys and the sequence of their action will be understood from the illustration given at right corner of fig. 114.

In the following investigations, intact or cut specimens of various plants have been successfully employed ; among these may be mentioned seedlings of *Helianthus annuus* and of *Impatiens*, also the climbing stem of *Ipomoea pulchella* and *Porana paniculata*. The excitability depends on age, season, and the previous history of the plant. Under favourable circumstances very pronounced response is obtained with an electric shock so feeble as to be below human perception.

After making the necessary electric connexions, the

specimen is allowed a period of rest for the complete subsidence of irritation caused by manipulation. The characteristic responses of variation of electric resistance are then obtained under sub-minimal, moderate, and strong stimulation.

EFFECT OF STIMULUS OF MODERATE INTENSITY

Experiment 110.—The intensity of the stimulus is continuously increased by the approach of the secondary coil to the primary till the amplitude of the resulting response



FIG. 115.

FIG. 115. Effect of electric stimulation of moderate intensity. Response by diminution of resistance shown by the up-curve.



FIG. 116.

FIG. 116. Effect of feeble electric stimulation. Response by increase of resistance exhibited by the down-curve (*Helianthus*).

is about 3 centimetres. The duration of electric stimulation is only half a second, and successive stimulations of equal intensity are applied at intervals of 5 to 10 minutes. Fig. 115 shows (1) that the response is a *diminution* of

resistance as indicated by the up-curve; (2) that the recovery is complete on the cessation of stimulation; and (3) that the amplitudes of successive responses are equal under uniform stimulation. If successive stimulations are at short intervals, the protoplasmic recovery is then incomplete, and a sign of fatigue is exhibited by a diminution in the amplitude of successive responses. Another interesting phenomenon sometimes observed is the occurrence of alternating fatigue, that is to say, a large response followed by a small one, and this in recurrent series.

EFFECT OF SUB-MINIMAL STIMULUS

Experiment III.—I have already referred to the fact that the sign of mechanical response to a feeble stimulation is opposite to that to a moderate stimulus; this is specially the case when the tissue is in a subtonic condition (p. 51). It is very remarkable that the method of resistance-variation also shows that with a sub-minimal stimulus the sign of the response is the opposite to that with a stronger stimulus, namely, an increase of resistance instead of diminution (fig. 116). A parallel effect was observed in the case of electromotive response (p. 166).

MULTIPLE RESPONSE UNDER STRONG STIMULATION

It will be shown in a later chapter that sensitive plants exhibit a series of multiple responses under a single strong stimulation. Similar results are obtained by the method of electromotive variation, both sensitive and ordinary plants giving a series of multiple electric responses under strong stimulation.

Experiment 112.—By the application of strong stimulation, I obtained multiple response, the resistance of the tissue undergoing a recurrent variation.

I next describe the effect of photic stimulation.

QUADRANT METHOD FOR RESPONSE TO STIMULUS OF LIGHT

In order to obtain response by resistance-variation to photic stimulation, I have devised the highly sensitive Quadrant Method, the principle of which will be understood from the diagram given in fig. 117. The specimen is a leaf-blade of *Tropaeolum*, the four quadrants of which, P, Q, R, S, serve as the four arms of a Wheatstone Bridge. The diagonal connexions are made with the battery and the galvanometer respectively. Three contacts with the leaf are fixed, and

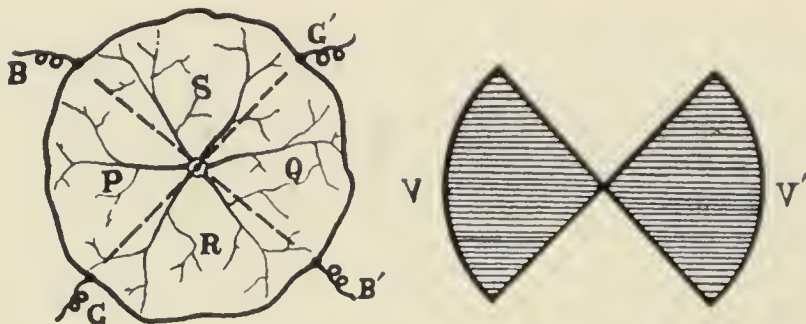

FIG. 117. The Quadrant Method for determination of variation of electric resistance under photic stimulation. Two opposite quadrants of the leaf are shaded. Electric connexions are made at the junction of the quadrants $B B'$ with the battery and $G G'$ with the galvanometer. $v v'$ are opaque screens to shield opposite quadrants from light (*Tropaeolum*).

the fourth is adjusted slightly to the right or to the left till exact balance is obtained in darkness, when $P Q = R S$. One pair of opposite quadrants, say P and Q, is shaded by a double V-shaped screen $V V'$. Exposure of the leaf to light produces a variation of resistance, not of one, but of two opposite arms of the bridge, R and S; the upsetting of the balance is thus due to the *product* of the variations of resistance in the two opposite quadrants. The sensitiveness of the method is very great, and a large galvanometric deflection in a particular direction indicates a diminution of the electric resistance of the quadrants stimulated by light. The result is further verified by a reversal experiment, when the double V-shaped screen is turned through 90° ; the quadrants

P and Q are then exposed to light, R and S being shaded from it. The resulting upset of the balance causes a galvanometer deflection which is now in the opposite direction. The reliability and sensitiveness of the Quadrant Method may thus be tested by obtaining opposite responses on alternate illumination of the two pairs of quadrants.

UNIFORM RESPONSES

Experiment 113.—After securing a perfect balance in the dark, the double V-shaped screen is fixed, and the leaf is mounted in a rectangular dark chamber, closed except at the front which carries a photographic shutter by which

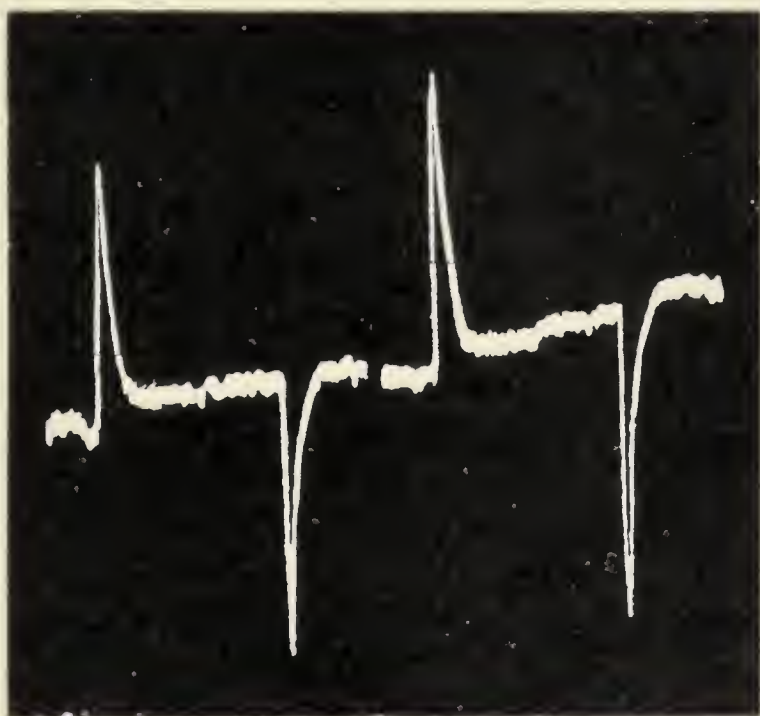

FIG. 118. Equal responses in opposite directions on alternate illumination of the two pairs of quadrants (*Tropaeolum*).

one pair of quadrants can be exposed to light for a definite time. The source of light is an arc-lamp placed inside a lantern, the condenser of which sends out a parallel beam of light. A rectangular glass trough filled with alum-solution is interposed in the path of the light to absorb the heat-rays. The time of exposure is kept constant. Fig. 118 shows the

equal and opposite responses caused by alternate stimulation of the two pairs of opposite quadrants.

RESPONSE TO LIGHT FROM A SINGLE SPARK

Experiment 114.—It is possible to render the Quadrant Method extremely sensitive. This is illustrated in the record obtained of the effect of a spark produced by the discharge of a Leyden jar, the time of illumination being of the

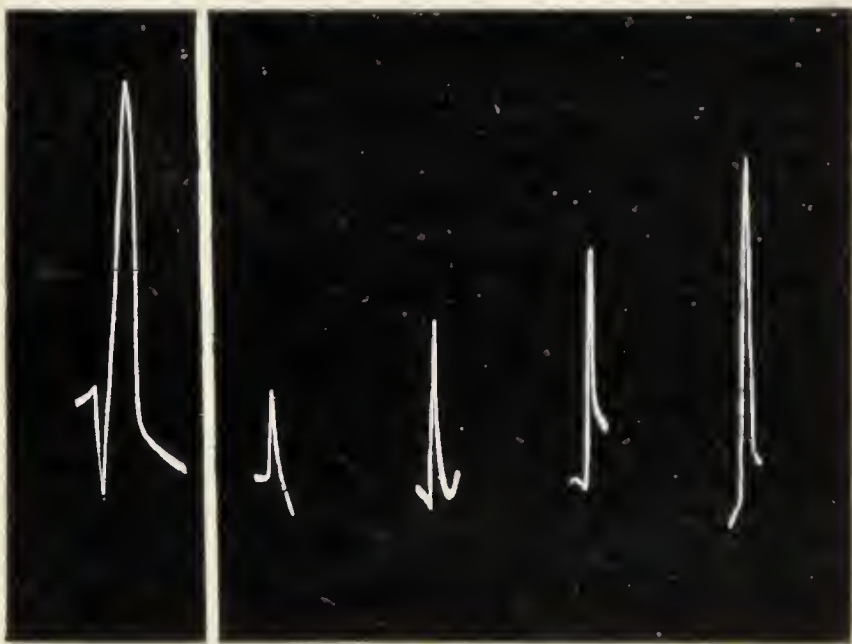

FIG. 119.

FIG. 120.

FIG. 119. Response to a single spark.

FIG. 120. Effect of stimulus of light increasing in the ratio
1 : 3 : 5 : 7. (Tropaeolum.)

order of about a hundred-thousandth part of a second. This spark flashed at a distance of 15 cm. from the leaf; the response is seen to consist of a preliminary positive twitch followed by a large negative response (fig. 119).

EFFECT OF INCREASING INTENSITY OF LIGHT

Experiment 115.—The arc-lamp was taken out of the lantern, and the responses to the diverging beam of light

obtained at different distances from its source. As the intensity of light varies inversely as the square of the distance, suitable marks were made on a scale fixed on the table, so that the intensity of light incident on the leaf was increased in the proportion of 1, 2, 5, 7 by bringing the lamp nearer to the leaf at the particular distances marked on the scale. The time of exposure was kept the same. The increasing intensity of light is seen to produce increasing amplitude of response (fig. 120).

EFFECT OF ANAESTHETICS

Experiment 116. *Effect of dilute vapour of chloroform on response to light.*—This gives rise to a preliminary enhancement of response followed by decline and abolition, an effect similar to those already observed by the methods of mechanical and electromotive responses.

DEATH-RESPONSE AT FATAL TEMPERATURE

I must anticipate certain results which are given in detail in a subsequent chapter. It will be shown that a sudden excitatory contraction of the plant takes place at the fatal temperature, normally at or about 60° C. There is also produced at this critical point a sudden change of galvanometric negativity, indicative of intense excitation at death.

Experiment 117. *Death-response and sudden diminution of resistance.*—The electric resistance of the pistil of Hibiscus was found to undergo a sudden diminution at the critical temperature of about 60° C.

POSITIVE AND NEGATIVE REACTIONS

As stated in a previous chapter there are two different reactions induced by stimulation, a positive and a negative. The positive reaction of a subtonic tissue, or of an ordinary tissue under feeble stimulation, is shown externally: (a) by expansion; (b) by an electromotive variation of galvano-

metric positivity; and (c) by an increase of the electric resistance of the tissue. The negative reaction, on the other hand, is exhibited (a) by contraction, (b) by an electromotive change of galvanometric negativity, and (c) by a diminution of the electric resistance of the tissue.

The following table shows parallel reactions manifested by diverse modes of response, mechanical and electric.

TABLE XIII.—SHOWING PARALLEL EFFECTS IN DIFFERENT MODES OF RESPONSE.

External change	Mechanical response	Electromotive response	Resistance variation
Sub-minimal stimulation	Expansion ; erectile response	Galvanometric positivity	Increase of resistance
Moderate stimulation	Contraction ; fall of leaf	Galvanometric negativity	Diminution of resistance
Strong stimulation	Multiple response	Multiple response	Multiple response

SUMMARY

Mechanical or electric stimulation induces a diminution of the electric resistance of the tissue.

The physiological character of the response by resistance-variation is demonstrated by the action of anaesthetics like chloroform, which produces a rapid diminution of the amplitude of response.

The response of subtonic tissue is an increase of resistance, instead of a diminution.

Strong stimulation gives rise to a series of multiple responses.

A very sensitive means for detecting the effect of light is the Quadrant Method of resistance-variation, the quadrants of the lamina of a leaf serving as the four arms of a Wheatstone Bridge.

The normal response to the stimulus of light is a diminution of electric resistance. Increasing intensity of light induces a corresponding diminution of resistance.

A sudden diminution of resistance occurs at the critical point of death.

Responses by mechanical movement, by electromotive change, and by resistance-variation, are different expressions of fundamental protoplasmic reactions induced by external stimulation.

CHAPTER XVI

THE DEATH-SPASM IN PLANTS

THE various symptoms of death in plants, such as drooping, withering, discoloration, and the escape of coloured cell-sap, do not manifest themselves at the moment of death, but at a very much later period. Even after a plant has been subjected to a temperature in excess of the fatal degree, it continues for a time to appear fresh and living. How then is it possible to distinguish a living from a dead plant, and to determine the exact moment of transition ?

Such a discrimination is possible by watching the waning of some characteristic sign of the living condition, the death-point being indicated by its disappearance at the critical moment. I have shown that the electric response affords a criterion of the living condition of the tissue, the response disappearing after the death of the organ. The ideally perfect method, however, would be the discovery of a reaction which, at the moment of death, should undergo a sudden reversal to its opposite. There would then be not even that minor degree of uncertainty which is inseparable from the determination of the vanishing point of a waning effect. Such a perfect method has been discovered by the detection of various spasmodic changes occurring in the plant at the moment of death.¹

In order to obtain a record of the death-reaction it is necessary to bring about death in a gradual manner. For this, two different methods have been found suitable. The

¹ *Plant Response*, p. 148; *Comparative Electro-Physiology*, p. 194; *Irritability of Plants*, p. 98; *Life Movements in Plants*, p. 776.

first is to subject the plant to a continuous rise of temperature till the fatal degree is reached. The second method, not so perfect as the first, is to apply a dose of dilute poison which proves fatal after a longer or shorter period, depending on the dose and on the virulence of the poison.

I will first show that a violent spasmodic movement occurs in *Mimosa* at the moment of death.

THERMO-MECHANICAL CURVE OF DEATH

The specimen of *Mimosa* is placed inside a double-walled bath; the outer bath is filled with water, and gradual rise of temperature is produced by application of heat outside, the plant being placed in the internal chamber kept in proper humid condition. It is necessary to produce a gradual and continuous rise of temperature, for any sudden variation would produce an excitatory fall of the leaf.

Experiment 118.—A leaf of the plant was attached to the recording-lever in the usual manner. The recording apparatus was of the oscillating type, in which the plate is made to move to-and-fro by an electro-magnetic contrivance, so that the record consists of a series of dots. The record of the movement of the leaf was taken under a definite rise of temperature of 1° C. per minute, from 25° C. upwards; the down-curve represents expansion, the up-curve contraction (fig. 121). The curve shows an increasing expansive movement which was continued till the temperature reached 60° C. After this a violent and spasmodic contraction took place, the curve exhibiting a sudden inversion. The intensity and abruptness of the contractile movement was so very great that the recording-lever was jerked off the recording-plate. In order to represent adequately the contractile portion of the curve, the intervals between successive dots had to be reduced so as to represent one-fifth of a degree.

The sudden contraction at 60° C. is the death-spasm of the plant, for it is the last response given by the plant, as will be seen from what follows.

Experiment 119.—In plants with thick stems, the attainment of the external fatal temperature by the interior of the plant is a slow process ; hence stout plants have to be subjected for a longer period to the fatal temperature to ensure death. It often happens that in such cases the temperature of the bath may rise one or two degrees above the critical



FIG. 121. Death-curve of Mimosa.

Successive dots in down or expansive part of curve represent rise of temperature of 1° C. per minute. Spasmodic contraction causing inversion of curve took place at 60° C.

temperature of 60° ; hence thick organs, generally speaking, show a slightly higher death-point. Thin seedlings, however, quickly succumb to the action of the fatal temperature. Two batches of similar seedlings of Mimosa were placed in the same bath, the rate of rise of temperature being 1° C. per minute. The first batch was taken out of the bath at a few degrees below 60° and placed in water at ordinary temperature. The second batch in the thermal bath exhibited the spasmodic fall of the leaves at 60° , after which

they also were placed in water at the temperature of the room. The first batch exhibited, after 2 hours, renewed signs of life and excitability, whereas the second batch never revived. The spasmodic movement of the fall of the leaf at 60° C. may therefore be regarded as the death-spasm in plants, corresponding to the death-throe in animals.

THERMO-MECHANICAL RECORD AFTER DEATH

Experiment 120.—The total abolition of response after exposure to the critical temperature is independently shown by the accompanying record, obtained with a particular specimen after the record of its death-spasm. The hot water in the bath was replaced by cold, and a record was



FIG. 122. Abolition of response to warming or cooling in specimen which had passed the death-point.

taken of the effect on the plant of rise and of fall of temperature. In the lower curve is shown the record of the effect of rise of temperature from 45° to 65° , and in the upper, the effect of cooling from 60° to 45° . It is seen that while the living plant exhibited a spasmodic contraction at 60° there is no such effect in the present case (fig. 122). The very slight movement observable in the two curves is the physical effect of heating and cooling, which is quite negligible compared with the physiological erectile movement due to warming and the subsequent spasmodic contractile movement heralding the initiation of death-change.

LOWERING OF DEATH-POINT BY FATIGUE

Experiment 121.—As the death-spasm is a physiological response, a depression of vital activity may be expected to cause a dislocation of the death-point. This is found to be the case, for the critical death-point of a fatigued plant is found to be considerably lower than that of a fresh plant. In a particular instance, fatigue induced by tetanising induction-shocks lowered the death-point from the normal 60° C. to 37° C., that is to say, by as much as 23° (fig. 123). Wound or injury to the tissue also lowers the death-point.



FIG. 123. Lowering of death - point under fatigue; death-spasm took place at 37° C.

There is some instability in the death-response between the temperatures of 55° and 60° C. If the specimen is suffering from injury, the death-point is found to be lowered by 3 or 4 degrees. A young plant dies a little earlier than an old one. For reasons already explained, the temperature of death-spasm in stout plants is often higher by 1 or 2 degrees.

POST-MORTEM RELAXATION

The excitatory response of the leaf of *Mimosa* at death is an active contraction of the pulvinus. The death-spasm is after a time followed by a post-mortem relaxation. This slow reaction is, however, quite different from normal erectile recovery from ordinary stimulation as exhibited by the living leaf. Moreover, the leaf, killed by high temperature, exhibits no further response to stimulation.

The question that next demands attention is whether the sudden excitation at death occurs only in sensitive plants,

or whether it is exhibited by all plants and their different organs? Should such an excitatory reaction occur at the critical temperature, how are we to detect it?

DEATH-EXCITATION IN ALL PLANTS

The characteristic excitatory reactions of different plant-organs have been described in a previous chapter. For convenience of reference I here classify them, beginning with the complex pulvinated and ending with the simple radial organ.

1. *Pulvinated organs*.—The lower half of the organ is more excitable than the upper half. Excitation causes the responsive fall of the leaf by the greater contraction of the lower half of the organ.

2. *Pulvinoids*.—The petiole of many leaves functions as an elongated pulvinoid, response to excitation being exhibited by a fall of the leaf.

3. *Anisotropic growing organs*.—Many floral leaves exhibit differential excitability of their upper and under sides. Response to excitation is brought about by the greater contraction of the more excitable side of the organ.

4. *Organs with induced anisotropy*.—Straight radial organs have been shown to become curved and anisotropic under unilateral stimulation. The expanded convex side of the organ is then found to be more excitable than the contracted concave side; hence excitation causes a straightening of the curved organ by the greater contraction of the more excitable convex side. This type of organ may be regarded as an intermediate link between a radial and a pronouncedly anisotropic organ.

5. *Radial organs*.—A radial organ, under excitation, exhibits a longitudinal contraction indicated by shortening of its length.

These being the characteristic indications of excitatory reaction given by these different organs, it remains to

ascertain if these indications are given by them when exposed to the critical temperature.

THERMO-MECHANICAL RECORD OF ORDINARY PULVINUS AND PULVINOID

Experiment 122.—The record of the pulvinus of the Bean-plant is shown in fig. 124. There is an increasing expansive movement as the temperature rises from 30°



FIG. 124. Thermo-mechanical curve indicating death-point at 60° C. of leaf of Bean (*Phaseolus*).

onwards till a violent contractile spasm occurs at 60°. It is significant that the critical temperature is the same in sensitive and in ordinary plants. The thermo-mechanical curve of the ordinary plant is, moreover, found to be essentially similar to that of *Mimosa*.

Experiment 123.—As an example of a pulvinoid I employed the leaf of Water Hyacinth (*Eichhornia*). The

up-movement of the leaf was slight during rise of temperature, but the spasmodic contraction at the fatal temperature of 60° C. was very pronounced (fig. 125).



FIG. 125. Determination of death-point of pulvinoid (*Eichhornia*). Death-spasm and inversion of curve at 60° C.

DEATH-EXCITATION OF ANISOTROPIC GROWING ORGANS

Experiment 124. *Death-movement of flowers.*—As already explained, the upper and under sides of each floral leaf are unequally excitable. The responsive movement at the critical temperature is one of curving up in certain cases and of curving down in others. In the case of the French Marigold grown in India, the florets of the ray curve up at the temperature of 59° .

DEATH-RESPONSE OF ORGANS WITH INDUCED ANISOTROPY

Experiment 125. *Death-excitation of geotropically curved organs.*—Physiological anisotropy has been shown to be induced in a radial organ by the unilateral action of the

stimulus of gravity, the convex side of the curved organ being the more excitable. The thermo-mechanical record of such an organ exhibits a preliminary expansion of the



FIG. 126. Death-spasm of the geotropically curved stem of *Basella alba*.

convex side; this expansion becomes converted into an abrupt and violent contraction at the critical temperature of 61° C. (fig. 126).

DEATH-EXCITATION OF RADIAL ORGANS

Experiment 126.—It has been shown that a radial organ responds to excitation by longitudinal contraction. Records were taken with two specimens of the style of *Datura alba* from the same plant. The two curves were so similar that one could be taken for the other. The curve of increasing expansion was found to be suddenly reversed

by the contractile spasm of death at 60° . The thermo-mechanical curve of the radial organ is in every respect similar to that of the leaf of *Mimosa*.

Diverse organs of plants, both sensitive and ordinary, are thus found to exhibit the characteristic spasm of death at the critical temperature, which is practically the same in all phanerogamous plants.

ELECTRIC EXCITATION AT DEATH

It has been shown that excitatory contraction can also be detected by two different electric methods; namely, by galvanometric negativity, and by diminution of electric resistance.

Experiment 127. *Electric spasm at death*.—Suitable electric connexions were made with upper and lower halves of a pulvinated organ. Rise of temperature, up to the critical temperature, induced expansion and galvanometric positivity of the more effective lower half of the organ. At 60° C. there was an abrupt inversion of the curve from electro-positivity to electro-negativity (fig. 127).

A sudden diminution of resistance is also found to take place at this critical death-temperature.

The life-and-death curves of different organs are seen to be essentially similar to each other. The following table shows that though the methods of determination are so widely



FIG. 127. Determination of the death-point by electromotive variation. The electromotive variation at the critical point is a change from electro-positivity to electro-negativity; the point of inversion of the curve is at 60° C.

different, yet they all give practically an identical value for the critical temperature of death. The electromotive and variation of resistance methods also give similar results.

TABLE XIV.—SHOWING CONSTANCY OF DEATH-POINT AT OR NEAR 60° C., EXHIBITED BY DIFFERENT ORGANS.

Specimen	Characteristic response at death
1. Pulvinus of Mimosa	Spasmodic fall of leaf
2. Pulvinus of Bean-plant	„ „
3. Petiole of Water Hyacinth	„ „
4. Spiral tendril	Movement of uncurling
5. Geotropically up-curved organ	Sudden down-movement
6. Floral organs	Opening or closing movement
7. Style of <i>Datura alba</i>	Longitudinal contraction
8. Coronal filament of Passiflora	„ „
9. Any anisotropic organ	Negative electric response
10. Radial organ	Sudden diminution of electric resistance

SUMMARY

When the leaf of Mimosa is exposed to a continually rising temperature, it shows an expansive erectile movement which is suddenly converted, at the critical temperature, into a fall of the leaf due to a spasmodic contraction. The thermo-mechanical record is V-shaped, the point of inversion being very sharp and well-defined. Under standard conditions the inversion takes place at 60° C., the sudden contraction being the death-spasm of the plant. There is a post-mortem relaxation succeeding the death-contraction.

Various other plants, sensitive and ordinary, exhibit the characteristic death-spasm at or about 60° C.

The death-point is lowered under physiological depression caused by fatigue or injury.

In a growing radial organ a longitudinal contraction takes place at the critical temperature. In an anisotropic

growing organ the death-spasm is exhibited by the predominant contraction of the more actively growing side of the organ.

A sudden excitatory change of galvanometric negativity occurs at the fatal temperature of 60° . The resistance of the tissue also undergoes a sudden diminution at this critical temperature.

CHAPTER XVII

THE TRANSMISSION OF DEATH-EXCITATION

IN the previous chapter, the occurrence of an intense excitation at the fatal temperature was demonstrated by the contractile movement of various motor organs. Now there are other tissues, mature stems for example, in which, on account of the presence of woody tissue, any mechanical movement of response is an impossibility. Do such rigid structures exhibit any excitation at the critical death-temperature? Again, it may be thought that the spasmodic fall of the *Mimosa* leaf at the critical temperature is due not to excitation but to the coagulation of the protoplasm at that particular temperature. This supposition fails, however, to explain the lowering of the death-point under fatigue (Experiment 121).

The following method of investigation was devised to prove that excitation is induced even in woody stems at the fatal temperature. The excitation was detected by its transmitted effect. It is well known that stimulation of a point on the stem of *Mimosa* gives rise to an impulse which causes the fall of the distant leaves; this effect is produced, as shown by the following experiment, where the stimulus is the excitation induced at death. Since the indicating leaves are maintained at normal temperature, their responsive fall cannot possibly be attributed to coagulation.

Experiment 128. *Transmitted death-excitation of Mimosa.* An isolated shoot of *Mimosa* bearing a number of leaves is taken and its cut end immersed in a water-bath to a depth of 2 cm. The leaves of a cut shoot, as already explained,

regain their normal excitability in the course of an hour or so. The water of the bath was heated electrically by means of a coil of wire ; the heating current was so regulated that the rise of temperature was at the rate of 1° C. per minute. Steady rise of temperature of the water in the bath did not at first produce any noticeable effect ; but on the attainment of the critical temperature, an intense excitatory impulse was evidently generated in the immersed portion of the cut stem, for all the leaves fell in serial succession. That this excitation was due only to the local death of the immersed portion of the stem is proved by the fact that the leaves re-erected themselves in the course of about 20 minutes. Cooling the water of the bath and reheating it once more did not give rise to any further impulse, for the portion immersed was already dead. The stem was then lowered about 2 cm. deeper into the water, and repetition of the experiment caused a new excitatory impulse due to the death of the fresh portion of the living stem, indicated once more by the serial fall of the leaves. This affords conclusive proof of the occurrence of an intense excitation in a woody stem at death.

I then repeated the experiment with intact seedlings of *Mimosa*.

Experiment 129. *Transmission of death-excitation in intact seedlings.*—I took a batch of young seedlings of *Mimosa* and carefully removed them from the soil without injuring the roots. The lower portion of each plant was placed in the bath, the first indicating leaf being at a distance of 15 mm. from the immersed portion of the stem. The transmission of death-excitation was found to occur in four typical cases at 60° , 60° , 59° , and 60° respectively. These results prove that an excitatory impulse is generated at the fatal temperature, and that the death-point of a non-motile tissue, such as mature stem, is the same as that of the pulvinus. For establishing a wider generalisation, the experiment was successfully repeated with other species of sensitive plants, such as *Averrhoa Carambola* and *Biophytum sensitivum*.

Experiment 130. *Transmitted death-excitation in Averrhoa*.—A detached leaf was used. One of the sensitive leaflets was attached to the Oscillating recording apparatus. It will be shown in a later chapter that leaflets of *Averrhoa* and *Biophytum* react to intense excitation not by single but by multiple response. The cut end of the long petiole of the leaf was immersed in a bath and the temperature gradually raised at the standard rate of 1° C. per minute. The indicating leaflet was at a distance of 50 mm. from the cut end. When the temperature of the bath reached the

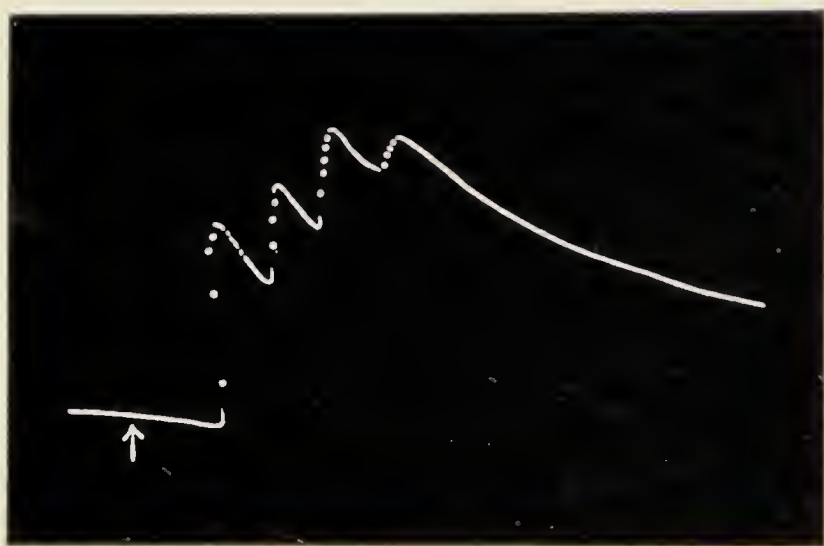

FIG. 128. Transmitted death-excitation at 60° C. gave rise to multiple response in *Averrhoa*.

critical point, an intense death-excitation was initiated and transmitted to a distance, causing multiple response of the leaflet (fig. 128). This was observed when the temperature of the bath had risen to 62° C. The death-excitation in the immersed portion of the stem must have occurred one or two degrees earlier, for a certain time must have elapsed for the impulse to reach the distant leaflet. Repetition of the experiment showed no response of the leaflet. But on lowering the petiole 2 cm. into the water the death-excitation of the fresh living portion gave once more the excitatory multiple response. I obtained similar results with *Biophytum*.

The experiments that have been described prove that an intense excitation occurs at the moment of death brought about by fatal temperature. Does this occur only when the plant is scalded to death, or does it also accompany death caused by other means? Is there, for example, any excitation at the fatal moment when the tissue is killed by poison? The question was investigated by subjecting a part of the plant to the action of poison, and noting whether an excitatory impulse was generated at the fatal moment.

DEATH-EXCITATION UNDER ACTION OF POISON

Experiment 131. *Effect of dilute solution of poison.*—I took some seedlings of Mimosa with their roots immersed in a beaker of water; the distance of the nearest motile leaf was 2 cm. above the level of immersion. Another beaker was prepared containing 1 per cent. solution of potassium cyanide. The poison was applied to the roots of the plants by substituting for the beaker containing water, that containing the cyanide solution. The solution was slowly absorbed and the sudden and serial fall of leaves indicated the transmitted death-excitation which occurred 212 seconds after the application of the poison, this being the average interval. The solution thus became effective in initiating death after continuous application for about 3.5 minutes. It appeared probable that a stronger poisonous solution would prove effective in a shorter time.

Experiment 132. *Effect of a stronger dose of poison.*—The experiment was repeated with a second batch of similar seedlings, the strength of the cyanide solution being increased from 1 to 5 per cent. The average period for initiation of death-excitation by the 5 per cent. dose was found to be 51 seconds, instead of 212 seconds by the 1 per cent. solution. The hastening of death is thus seen to be approximately proportional to the strength of the dose.

Experiment 133. *Comparison of virulence of different poisons.*—The initiation of death is not merely determined

by the strength of the dose but also by the virulence of the poison. In order to compare the poisonous action of potassium cyanide and of mercuric chloride, I repeated the experiment with 1 per cent. solution of the latter poison. The average period for the initiation of death-excitation was found to be 650 seconds, in place of 212 seconds with 1 per cent. solution of potassium cyanide. The poisonous action of potassium cyanide on the plant may therefore be regarded as three times more virulent than that of mercuric chloride.

TRANSMISSION OF DEATH-EXCITATION AND TRANSLOCATION OF POISON

A misgiving might arise that the fall of the indicating leaf was due not to the transmission of the death-excitation, but to the direct action of the poison carried to the leaf itself by the movement of sap. This is, however, negatived by the subsequent erection of the leaf after the passage of the impulse; translocation of the poison would permanently abolish all power of response. The following experiment was devised for preventing even the remote possibility of the transfer of the poison to the indicating leaf.

Experiment 134.—The thin long flower-stalks of *Biophytum* are very effective in conducting excitation. When these are stimulated in any way, excitation travels downwards and overflows into the rosette of leaves which bear numerous pairs of sensitive leaflets, and causes successive closure of the leaflets from the centre outwards. One drop of 5 per cent. solution of KCN was applied to the tip of the flower-stalk, special care being taken that the poison did not leak downwards. In these circumstances there was no possibility of the transport of the poison downwards against the direction of ascent of sap. Excitation was nevertheless initiated at the poisoned tip of the flower-stalk, and transmitted to the leaves below, as shown by the successive

closure of their leaflets. The transmitted excitation was so intense that it gave rise to a series of multiple responses of the leaflet attached to the recorder (fig. 129). After recovery from multiple pulsation, the leaflet was directly subjected to moderate stimulation at the point marked with a cross. This gave rise to a single response, proving once more that the poison had not reached it. The multiple response

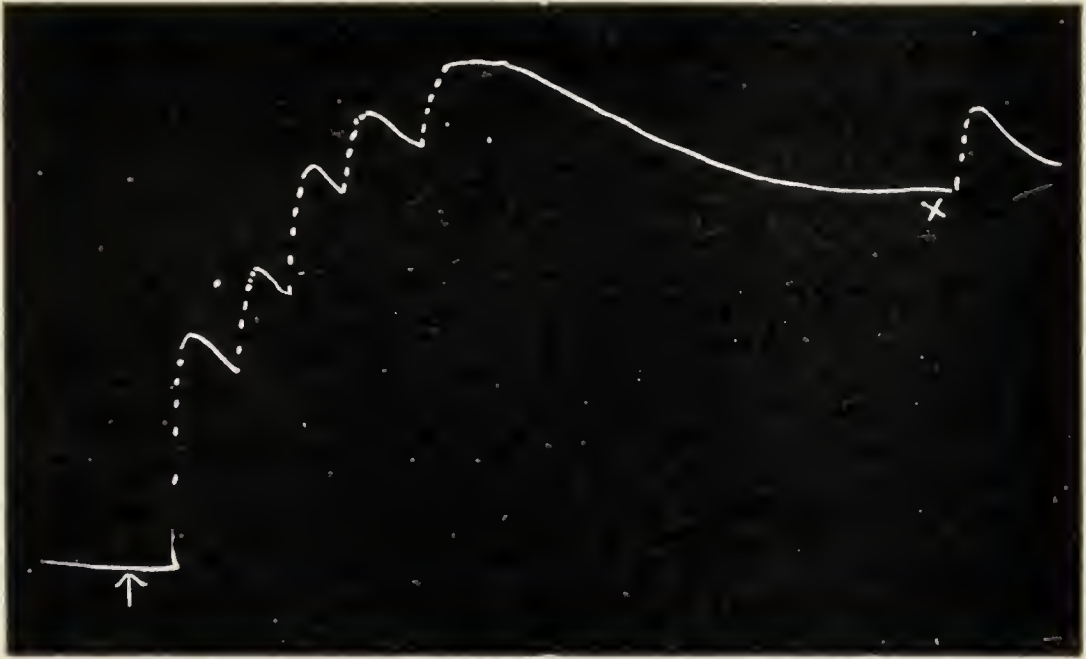

FIG. 129. Multiple response of leaflet of *Biophytum* under transmitted death-excitation due to poisoning.

Local stimulation of the leaflet at cross x gave rise to a single response. (See text.)

therefore indicated the intense death-excitation initiated at a distance.

The results obtained with different organs of plants under diverse methods of investigation concur in proving that an intense excitation occurs at the death of the tissue, whether this is brought about by poisoning or by a rise of temperature to the fatal degree. I describe in the two following chapters the results of another method of inquiry which gave identical value for the fatal temperature.

SUMMARY

At the moment of death, violent excitation is developed in the tissue.

The excitation at death has been shown to be conducted to a distance, causing excitatory fall of the indicating leaves in sensitive plants. Thus, on locally raising the temperature of a portion of stem, an excitatory impulse was found to be generated there at a definite critical temperature. The death-points of motile and non-motile tissues are found to be the same.

Death-excitation, locally initiated by the action of poison, is also transmitted to a distance. The duration of application for producing death-excitation is found to depend on the strength of the dose and on the virulence of the poison.

CHAPTER XVIII

RECORD OF DEATH BY APPARENT VARIATION IN WEIGHT

It was shown in previous chapters that the spasmodic contraction of living cells, accompanied by a spasm of electric negativity, gives a definite indication of irreversible change associated with death. It appeared probable that additional modes of response might be available for the immediate detection of the initiation of death in the tissue of plants. The following investigation was undertaken to ascertain whether any sudden change in weight occurs when the tissue immersed in a water-bath is raised to the fatal degree of temperature.

THE RECORDING BALANCE

The plant-specimen, suspended by a waxed cocoon-thread from the right pan of a balance, was immersed in water, its weight in water being exactly balanced by suitable counterpoise placed on the left pan (fig. 130). The thin brass vessel containing the water in which the specimen is immersed is double-walled, and an electric coil for heating is arranged below it. By regulating the electric current, the rate of rise of temperature was adjusted at 1° C. per minute. The heated water between the two walls of the vessel raises the temperature of the water in the interior so uniformly that any disturbing action of convection currents on the immersed specimen is eliminated. Should the specimen lose weight during rise of temperature, the long index of the balance will move to the right (down-curve);

an increase in weight, on the other hand, will be indicated by a movement of the index to the left (up-curve).

The record is taken on a smoked-glass plate allowed to fall at a uniform rate of 10 cm. in 40 minutes, which is

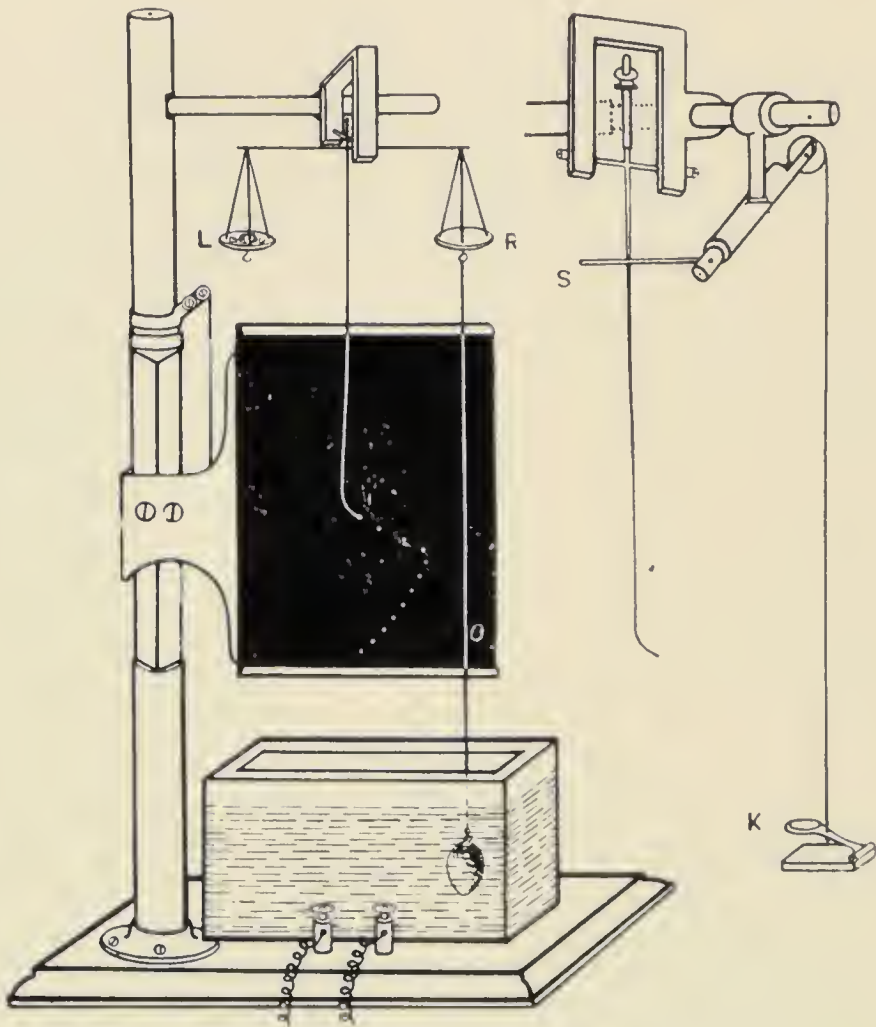

FIG. 130. The Balance for recording apparent variation in weight at death.

The immersed specimen suspended from right pan R counterpoised by weight placed on left pan L. Electric heating arrangement of bath not shown. K, press-key for making dotted record; the mechanism of the striker is shown on the right.

the duration of a single experiment. The bent tip of the writing-lever is at a distance of 2 mm. from the recording-plate. The record in the form of successive dots is obtained

by the employment of a striker ; this can be made periodically to press the writing-lever against the smoked-glass surface, thus making a dotted record. The striker consists of a thin horizontal rod ; a second rod at right angles to the striker passes through a guide tube, inside of which is a spiral spring by which the striker is kept at a short distance from the writing-lever. A string from the end of the second rod passes over a pulley, and terminates in a press-key K. An observer watches the thermometer in the bath and presses the key so as to make a dot for every degree rise of temperature ; the interval between two successive dots thus represents a rise of 1° C.

The water in the bath is freed from absorbed air by previous boiling. The air which may have remained entangled in the tissue is also removed by placing the specimen, immersed in a beaker of water, under the receiver of an air-pump. The air-bubbles are removed by repeated production of vacuum and restoration of normal pressure. The specimen, generally speaking, is heavier than water, and sinks when suspended in the water ; when it is lighter, a little weight has to be attached to it to make it sink.

DEATH-RECORD OF FRUIT BY VARIATION IN WEIGHT

Experiment 135.—For the first experiment of the series I took a fruit of *Carissa Carandas*. The record (fig. 131) shows a change in weight during the rise of temperature. A loss in weight occurred between 45° and 60° , after which there was an abrupt inversion of the curve, the up-movement of which indicated a sudden increase in weight.

Experiment 136.—The fact that sudden change in weight is a final irreversible death-response was proved by taking a record of the effect of variation of temperature on a specimen which had already been killed by exposure to the fatal temperature. This did not show any such variation in weight at the critical temperature as did the living specimen.

The death-curve of variation in weight exhibits a striking similarity to the thermo-mechanical death-curve of *Mimosa* and other plants (*cf.* fig. 121). *The loss in weight* in one case corresponds with the expansive movement in the other. Again, *the sudden increase in weight* at death in the present case has a correspondence with the spasmodic contraction of the pulvinus of *Mimosa*. The significance of this similarity will be pointed out later.

In describing the thermo-mechanical curve in a previous chapter, it was explained that the death-point is lowered by



FIG. 131. Record of variation in weight of *Carissa* fruit under rise of temperature (45° – 60° C.).
Note abrupt inversion of the curve at 60° C., indicating a sudden increase in weight.

a few degrees when the specimen is suffering from recent injury. In the present method, also, the point of inversion (sudden increase in weight) is often lowered by a few degrees on account of injury. A semi-conducting bulky structure was found to exhibit the mechanical death-inversion at one or two degrees above the normal 60° C.; a similar variation is also observed in the record of such bulky objects by the method of variation in weight.

This abrupt change in weight at death is not only exhibited by fruits but also by other organs, such as the stem, the petiole, and the root. Certain specimens exhibit it

more strikingly than others. I will, in the course of this chapter, give typical examples of death-response of various organs.

POST-MORTEM VARIATION IN WEIGHT

The death-contraction of *Mimosa* is subsequently reversed into a post-mortem relaxation (p. 204). Similarly, the

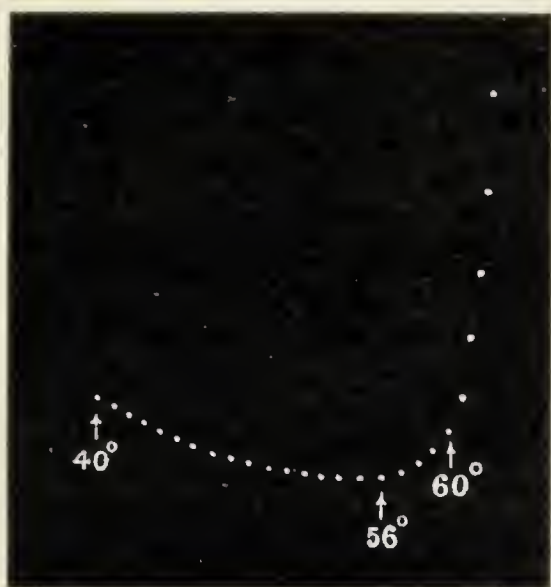

FIG. 132. Death-record of fruit of *Solanum*.

Reversal began to take place at 57° C., there being a marked increase in apparent weight at 60° C.

sudden increase in weight at death gradually disappears, and the curve returns to the original position.

Before turning to the records of other organs, I give an additional record obtained with another fruit.

Experiment 137. *Death-record of the fruit of Solanum*.—The down-curve of *Solanum*, indicating loss in weight, was arrested and gradually reversed after 56°; at 60° the rate of increase in weight was very pronounced, as seen in the sudden erection of the curve (fig. 132).

DEATH-RECORD OF STEM

Experiment 138.—Fig. 133 shows the record obtained with the stem of *Basella*. A sudden increase in weight

occurred at the temperature of 61° . The stem was thick, hence the death-point was slightly higher than usual. I obtained similar results with the stem of the Gourd.



FIG. 133. Death-record of stem of *Basella*.
Sudden inversion at 61° C.

DEATH-RECORD OF PETIOLE

Experiment 139. *Death-record of Arum indicum*.—A small piece was cut off the young petiole of *Arum indicum*



FIG. 134. Death-record of petiole of *Arum indicum*.
Sudden increase in weight at 61° C.

and allowed a long period of rest to recover from the shock of operation. It was then suspended from one arm of

the balance in the usual manner. The record obtained is similar to that of fruits and stems, the point of death-inversion and sudden increase in weight being 61° C. (fig. 134).

DEATH-RECORD OF ROOT

Experiment 140.—The specimen employed was a small piece of Beetroot. Rise of temperature produced an increasing loss in weight which culminated at 61° C., after which the curve exhibited an abrupt inversion indicative of a sudden increase in weight. I also obtained similar results with Radish.

The characteristic variation in weight under change of temperature—an increasing loss followed by a sudden gain at the critical temperature—was thus exhibited by various organs of plants.

The question now arises, What is the underlying cause which gives rise to this characteristic variation in weight? and further, Why should the curve of variation in weight bear such a striking resemblance to the thermo-mechanical curve? In both there is a sudden inversion of the curve at the fatal temperature. The records obtained by these different methods must evidently refer to a definite reaction which is fundamental.

In regard to the sudden increase in weight at the critical temperature, it has been shown that a dead tissue exhibits no such change (Experiment 136). The phenomenon must therefore be essentially physiological. Nevertheless, a physical factor is present, namely, thermal expansion of the immersed tissue and resulting increase of buoyancy during rise of temperature. How is the purely physiological factor to be discriminated from the physical? The problem was solved by balancing the living against the dead tissue.

RECORD OF LIVING TISSUE BALANCED BY DEAD

Experiment 141.—A living fruit of *Carissa* suspended from the right pan of the balance was counterpoised by a dead fruit of the same size suspended from the left pan, the second specimen having been previously killed by boiling water. Both were immersed in the same heating bath after exact balance had been obtained by placing fragments of aluminium in one or the other pan. The two specimens



FIG. 135. Record of living tissue balanced by dead.
Sudden increase in weight at 57° C.

on opposite sides of the balance were thus subjected to the same physical conditions.

The record (fig. 135) so obtained exhibits, therefore, the effect of the purely physiological variation of the living tissue. The first part of the curve shows a loss in weight which was slight; in other cases the loss was a little more pronounced. At the critical death-point, in this case at 57° , there is an abrupt inversion of the curve indicating a sudden increase in weight. In every case the death-spasm is violent in its abruptness and intensity.

THE FUNDAMENTAL PHYSIOLOGICAL REACTION

I will now endeavour to explain the variation in weight induced by change of temperature, and to give the reason of the similarity between the thermo-mechanical curve and that of the variation in weight.

In regard to the apparent weight of the organ measured by the balance, it should be remembered that it is the real weight *W* minus the weight of the volume of water displaced by the organ. Now, a physiological expansion of the organ must obviously increase the volume of water displaced by it, and thus cause an apparent diminution in weight as recorded by the balance. Conversely, an abrupt contraction and diminution in volume of the organ involves a reduction of the volume of water displaced, which causes a sudden increase in its apparent weight. The increasing loss in weight up to the critical temperature is therefore due to the physiological expansion of the organ; the sudden increase in weight and inversion of the curve are, on the other hand, due to the spasmodic death-contraction of the organ as a whole.¹

The thermo-mechanical curve and that of weight-variation, recording the effect of rise of temperature to the death-point, resemble each other because they represent the same physiological changes, expansion and contraction. But whereas the method of thermo-mechanical curve is especially applicable in the case of anisotropic organs, the method of weight-variation described in the present chapter extends the scope of inquiry to all organs and establishes a wider generalisation.

SUMMARY

The curve obtained by the Recording Balance shows that a living tissue heated in a water-bath exhibits, during rise of temperature, a continuous diminution in weight till at

¹ The death-record occasionally exhibits a diminution in weight when the death-spasm is attended by a considerable expulsion of sap from the tissue.

the critical temperature of about 60° C. there is produced a sudden increase in weight. A tissue which had been previously killed exhibits no such variation in weight.

The effect of physical factors is eliminated by balancing a dead organ against a living one ; so the curve thus obtained exhibits the effect of purely physiological variation.

The curve of variation in weight under changes of temperature is in every way similar to the thermo-mechanical curve. Both exhibit a sudden inversion of the curve at the fatal temperature.

The change in weight is shown to be due to physiological expansion or contraction. The sudden increase in weight at the critical temperature is due to abrupt volumetric contraction which is the spasm of death.

CHAPTER XIX

AUTOMATIC PULSATION

THE movements induced by external stimulation have been fully described in previous chapters. There are, however, other movements of a pulsatory nature which are apparently not induced by any external stimulation and are therefore described as automatic or spontaneous. The manifestations of these automatic activities are sometimes on a macroscopic scale, the pulsations being readily visible. They are exhibited in a striking manner by the heart of the animal. Similar activities are also exhibited by plants, notably by the leaflets of *Desmodium gyrans*. There are, in addition, other pulsatory activities of great functional importance to the life of the plant, which being on a microscopic scale have not hitherto been suspected. The method of detection and record of these imperceptible pulsations will be described in a later chapter.

RECORD OF PULSATION BY OSCILLATING RECORDER

Desmodium gyrans, or the Telegraph Plant, grows wild in the Gangetic plain. It is a Papilionaceous plant, with trifoliate leaves, of which the terminal leaflet is large and the two lateral ones very small (fig. 136). Each of these has a small pulvinule, the periodic contraction and expansion of which cause rhythmic down-and-up movements.

For experimental purposes it is more convenient to take a detached petiole carrying the pulsating leaflets. The amputation is often followed by an arrest of pulsation, due to the shock-effect of operation. The pulsations are, however, revived after a suitable period of rest.

The petiole bearing the leaflets is mounted in a U-tube. A stopcock allows the water to be replaced by any required solution poured through the funnel-end of the tube, so that the effect of different chemical solutions on the rhythmic activity can be easily studied. A light chamber with mica windows is made to enclose the specimen. The temperature in the chamber can be raised to any desired degree by means of an electric current sent through a spiral of heating wire ; or be lowered by sending a stream of cooled air through it. Various gases and vapours can be similarly passed through it (fig. 137).



FIG. 136. Leaf of *Desmodium gyrans*, natural size.

The two small lateral leaflets exhibit automatic movements.

To record the pulsations, the short arm of the writing

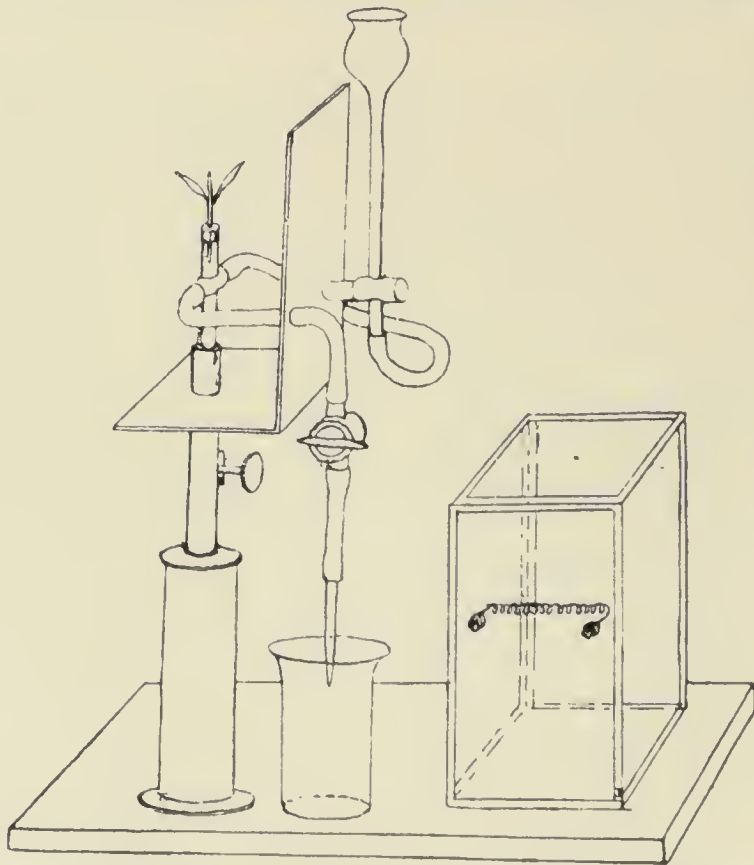

FIG. 137. U-tube support for the leaf, and the plant-chamber.

lever is connected, by means of a cocoon-thread and a drop of shellac-varnish, to a point about the middle of the leaflet. As the pull exerted by the leaflet is very feeble, the writing-lever has to be made extremely light. The record is

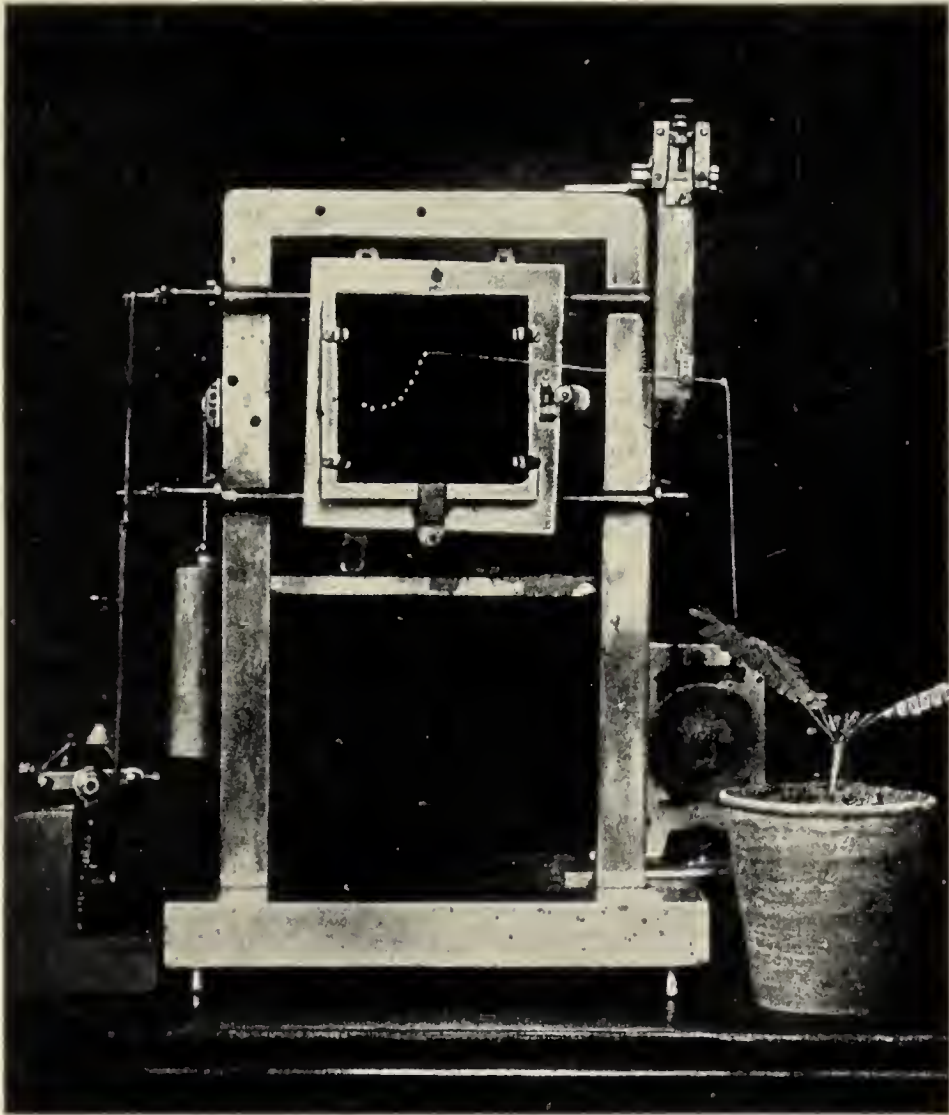

FIG. 138. Photograph of the Oscillating Recorder, reduced to one-fourth the natural size.

taken with an Oscillating Recorder, one type of which is seen in fig. 138. The recording-plate is made to move to-and-fro by an eccentric so that a dotted record is traced on the moving smoked-glass plate, the interspaces indicating definite intervals of time.

TIME-RECORDS OF SYSTOLIC AND DIASTOLIC MOVEMENTS

Experiment 142.—Each complete pulsation of the leaflet consists of a relatively rapid down or systolic movement,

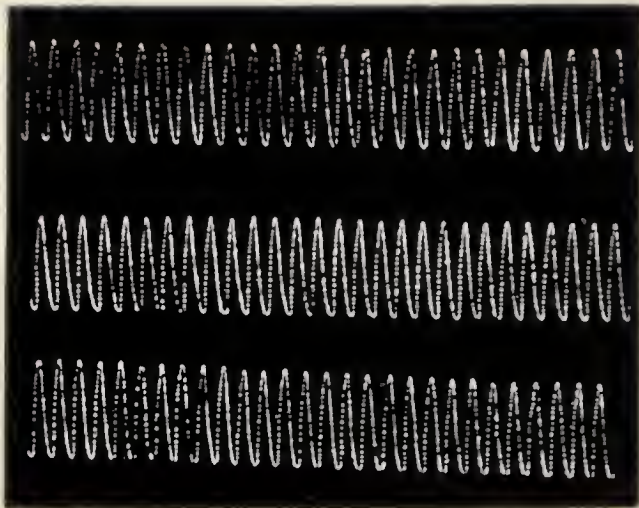

FIG. 139. Continuous record of pulsation of *Desmodium* leaflet for 4 hours.

followed by a slower diastolic up-movement, there being an intervening pause at the turning-points.

The record of the pulsation of the *Desmodium* leaflet is remarkably similar to that of the heart-beat of the animal, as summarised below :

- (1) The pulsations exhibit sometimes a notch of a dicrotic nature during either systole or diastole (*cf.* fig. 209). They often exhibit periodic groupings.
- (2) The amplitude of pulsation of one beat may be very large, and then that of the next one is very small, as if a large discharge caused fatigue for the next pulsation.
- (3) Under favourable conditions the irregular pulsations become regular and uniform.

The uniformity of pulsation of the *Desmodium* leaflet under favourable conditions is clearly shown in the continuous record for 4 hours given in fig. 139. The pulvinule

is sensitive to light ; it should therefore be adjusted with its length perpendicular to the window so that its two flanks are equally illuminated. Stronger illumination of one flank gives rise to elliptical movement of the leaflet.

The record of a single pulsation, magnified $2\frac{1}{2}$ times, is shown in fig. 140, the successive dots being at intervals of 1 second. The period of a complete pulsation was 102 seconds, of which the down-movement (represented by

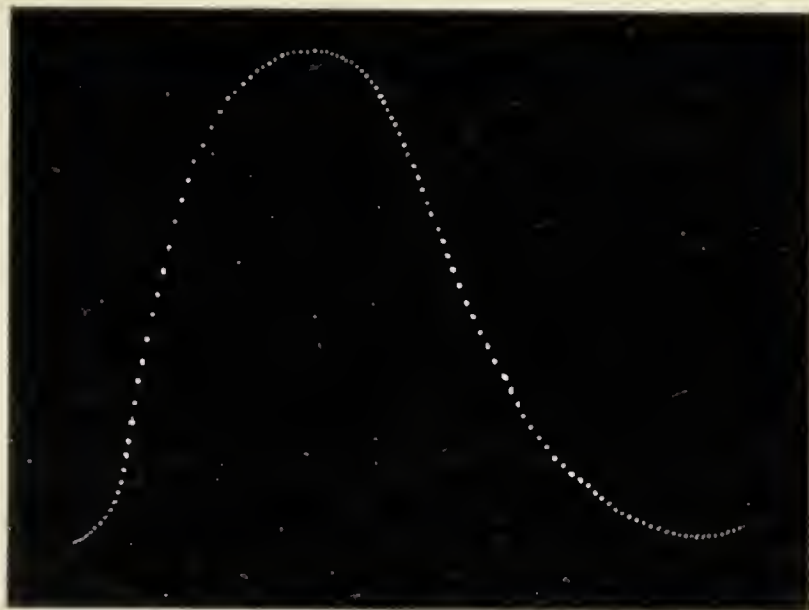

FIG. 140. Record of a single pulsation of *Desmodium* taken on a faster moving plate. Successive dots at intervals of 1 second.

the up-curve) was accomplished in 41 seconds, and the up-movement in 61 seconds. The leaflet attained its maximum rate at the fourteenth second of its actual downward journey, the maximum rate being 0.9 mm., and the average rate 0.44 mm. per second. The maximum rate of the up-movement was, on the other hand, 0.56 mm., and the average 0.3 mm. per second.

PULSATORY ACTIVITY DUE TO PREVIOUS STORAGE OF ENERGY

The tonic condition of a tissue, as previously explained, is determined by its energy-content derived ultimately from environmental stimuli. The power of contraction has

been shown to be dependent on the tonic condition. The possibility of repeated contraction exhibited by the rhythmic tissue of the Desmodium-leaflet is similarly dependent on previous storage of energy, as demonstrated by the following experiments.

Experiment 143. *Stoppage of pulsation by run-down of stored energy.*—The cut specimen, whose record in a lighted room for 4 hours is given in fig. 139, was removed to a dark room, and its record continued for the next 10 hours. The amplitude of pulsation was found to exhibit

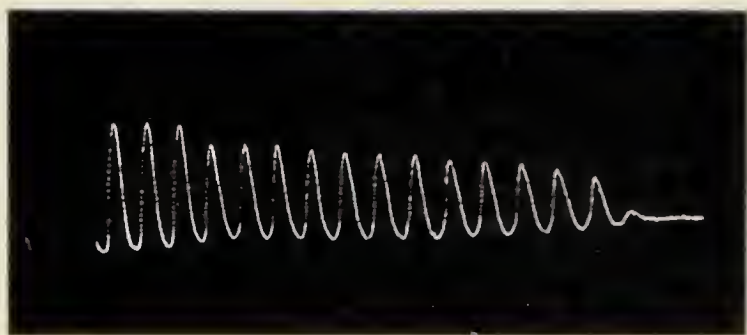

FIG. 141. Gradual stoppage of pulsation in isolated leaflet of Desmodium.

a continuous decline, and ultimately to come to a stop at the tenth hour in darkness (fig. 141), the tonic condition having by this time fallen *below par*. This arrest is not always indicative of the permanent abolition of irritability at death; it is often an instance of suspended activity due to run-down of energy, resulting in a subtonic condition of the tissue.

Since there is a possibility of revival of pulsatory activity by fresh stimulation, I therefore undertook to investigate:

- (1) The intensity and duration of stimulation necessary for revival of pulsation in tissues in different degrees of subtonicity, and
- (2) the relation of the persistence of pulsation to the quantity of incident stimulation.

EFFECT OF LOWERING OF TONIC LEVEL

In the case of a tissue immediately after the arrest of pulsation, its tonic level will have fallen but slightly below par. If, on the other hand, a long time has been allowed to elapse after the stoppage of pulsation, the tissue will have been rendered relatively more subtonic. The following experiments relate to the intensity and duration of stimulation required to revive pulsation (1) in a slightly and (2) in a more pronouncedly subtonic tissue.

Experiment 144. *Action of stimulus on slightly subtonic tissue.*—Light was applied for 2 seconds on a leaflet which had come to a state of standstill only half an hour previously. This gave rise to three recurrent responses, after which the multiple activity came to a stop. A second application of light for 2 seconds gave a similar result.

Experiment 145. *Action of stimulus on pronouncedly subtonic tissue.*—I next took a specimen which had been in a state of standstill for 5 hours; its tonic level had therefore become considerably lowered. Stimulus of light for 2 seconds was now found to be quite ineffective. It was only after the application of light for 30 seconds that the stimulus became effective, giving rise to a single response. The light was applied a second time, but for the longer duration of 60 seconds. The response now consisted of a large pulsation followed by two smaller ones.

RELATION OF THE PERSISTENCE OF REVIVED PULSATION
TO THE QUANTITY OF ABSORBED STIMULUS

The persistence of the revived activity will next be shown to depend on the intensity and on the duration of stimulation, that is to say, on the quantity of stimulus that impinges on the organ. The experiments were carried out with *Desmodium*-leaflets which had just come to a state of standstill. I studied the effect of both electric and photic stimulation.

Experiment 146. *Effect of electric shock.*—A single electric shock of moderate intensity gave rise to a single response; a repetition of a similar stimulation caused once more a single response (fig. 142).



FIG. 142. Response of Desmodium-leaflet in a state of standstill. Single response to single stimulation.

Experiment 147. *Effect of continuous induction-shock.*—The electric stimulation was in this case stronger and the duration of application was prolonged to 5 seconds. The effect was a long-continued pulsatory response of the leaflet originally at a standstill

(fig. 143). The persistence of revived rhythmic activity, therefore, depends on two factors, on intensity and on

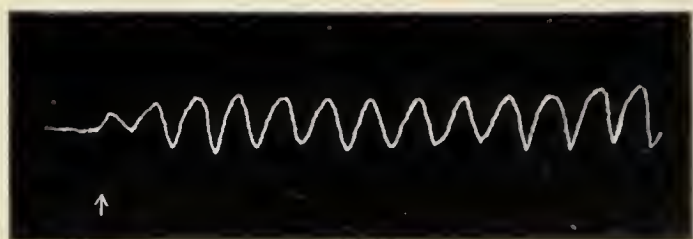

FIG. 143. Prolonged revival of pulsation under moderate electric stimulation for 5 seconds.

The leaflet was at standstill before stimulation at arrow.

duration; that is to say, on the quantity of impinging stimulus.

Experiment 148. *Effect of increased duration of stimulus of light.*—Similar effects were obtained under stimulus of light. The application of strong light for 5 minutes gave rise, in the present case, to a single pulsation of the leaflet, previously at standstill. The next application of light of the same intensity for 10 minutes gave rise to four pulsations, two during and two after the application. Light was next applied for 45 minutes, and the rhythmic activity then persisted for nearly an hour after the withdrawal of light (fig. 144).

To recapitulate :

1. The pulsating organ, after isolation from the stimulating agencies of its environment, comes to a state of standstill by the depletion of something that had been conserved.

2. In this state of standstill, stimulation revives the pulsatory activity, which becomes increasingly persistent

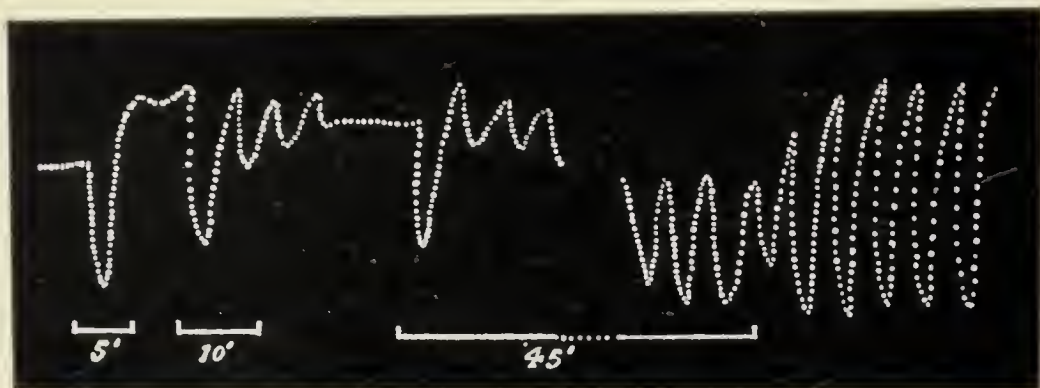

FIG. 144. Effect of photic stimulation in renewing pulsation of *Desmodium gyrans* originally at standstill.

Successive exposures to light for 5, 10, and 45 minutes. A portion of the record is omitted.

with the intensity and duration of incident stimulation. There must, therefore, be a causal relation between stimulation and pulsatory activity.

3. It is clear that the tissue, in consequence of stimulation, has regained its power of automatic pulsation which it had lost in the subtonic condition. In other words, previous stimulation has contributed sufficient energy to the protoplasm to restore its capacity for performance of its normal function.

MULTIPLE RESPONSE

The question next arises whether rhythmic activity was suddenly perfected in certain plants like *Desmodium*, or whether there were intermediate steps in the evolution. In regard to this, I have been able to discover a connecting link

between ordinary response, in which a single stimulation gives rise to a single response, and automatic movement of a rhythmic character. The phenomenon which bridges over the gap is that of multiple response. It has already been shown that rhythmic tissue which has come to a state of standstill responds to feeble stimulation by a single response, and to strong stimulation by a series of multiple responses (*cf.* Experiments 145, 146, 147). Similarly, tissues of many plants respond to feeble stimulation by a single response,



FIG. 145. Multiple response in *Biophytum* to a moderately strong electric shock.

and to stronger stimulation by repeated responses. This will be clearly understood from the following typical experiments carried out with *Biophytum sensitivum*.

Phenomenon of multiple response.—To a feeble electric stimulation applied to the petiole of *Biophytum*, the leaflet answered by only a single response.

Experiment 149. *Multiple response under strong electric stimulation.*—Stronger stimulation gave rise to a series of multiple responses (fig. 145).

Experiment 150. *Effect of strong thermal stimulation.*—As many as sixteen multiple responses were caused by a strong thermal stimulation.

Experiment 151. *Effect of chemical stimulation.*—Strong chemical stimulation gave rise to as many as



FIG. 146. Multiple response induced by chemical stimulation (Biophytum).

seven multiple responses, the average period being 30 seconds (fig. 146).

MULTIPLE RESPONSE OF ALL TISSUES

Multiple mechanical response under strong stimulation was also obtained with other sensitive plants like *Averrhoa* and *Mimosa*. I next attempted to discover if multiple

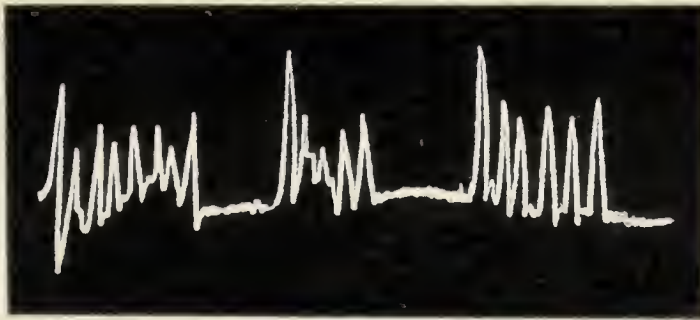

FIG. 147. Multiple electric response of Biophytum under thermal stimulation.

response were given by all tissues under strong stimulation, the excitation being detected by means of an electric response of galvanometric negativity.

Experiment 152. *Multiple electric response.*—The employment of the electric method demonstrated that every plant, both sensitive and ordinary, gave multiple excitatory response under moderately strong stimulation. Fig. 147

shows the multiple electric responses given by the petiole of *Biophytum* under thermal stimulations applied at intervals of 5 minutes. Each stimulation is seen to have given rise to from five to eight multiple responses, the average period of each pulsation being 30 seconds.

MULTIPLE RESPONSE UNDER DIRECT STIMULATION

In the multiple mechanical responses which have been described, the stimulus was applied at a distance from the

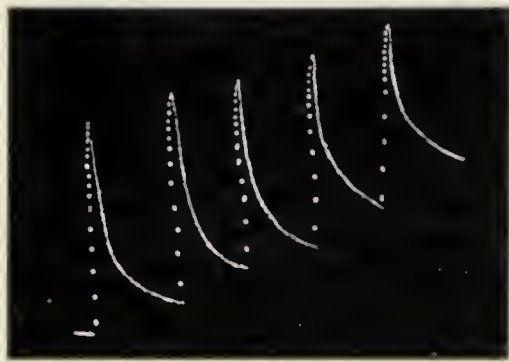

FIG. 148. Multiple response in *Biophytum*, under direct photic stimulation.

motile organ, the recurrent responses being due to the transmitted multiple excitations. The question arises whether the motile tissue is itself multiple-responding.

Experiment 153.—The leaflet of *Biophytum* was directly stimulated by light from an arc-lamp. This gave rise to multiple responses (fig. 148) which persisted for a time even after the stoppage of the stimulus of incident light.

The next point is to discover the intermediate stages of transformation from single to multiple response.

EFFECT OF INCREASING INTENSITY OF STIMULATION

Experiment 154. *Response on 'all or none' principle.*—The minimally effective intensity of electric stimulation for response of *Biophytum* was 0.1 unit. After taking the record under this minimal intensity, a second response to

stimulation ten times as strong, *i.e.* 1 unit, was recorded. It was found that both the minimal and maximal stimuli induced practically the same effect. The leaflet responds either to its fullest extent or not at all.

What then became of the excess of energy of the maximal stimulus? It is not necessary to suppose that in every instance the whole energy of the impinging stimulus is expended in the resulting movement; some portion of it may be wasted as heat, while another may be utilised to do the internal work of raising the tonic level of the tissue. The excess of energy derived from the incident stimulus may also find external expression in the form of responsive movement. To take a physical illustration, the energy stored up in a compressed spring, on release gives rise to long-continued and rhythmic oscillations. Similarly, the stored energy in a living tissue finds external expression in repeated responses, as illustrated by the following experiment.

Experiment 155.—Successive responses of *Biophytum* were recorded at intervals of 3 minutes to stimuli increasing from 0.1 to 2 units. Owing to incomplete recovery in each response, the base-line was displaced upwards. The amplitudes of successive responses, up to 1 unit, were nearly the same, though the stimuli were increasing. On the application of the fourth stimulus of intensity 2, the response became multiple (fig. 149). The repeated responses are therefore due to the excess of energy of the strong incident stimulus that was held latent in the tissue.

The question that naturally arises is: Why should the outflow of energy in the form of responsive movement occur in a pulsatory manner? In explaining this I will describe certain important characteristics of rhythmic tissues, such as those of the heart of the animal and of the pulsating pulvinule of the *Desmodium* leaflet. One such characteristic is the relatively sluggish contraction of the rhythmic tissue. Thus the period of contraction of the cardiac tissue is considerably longer than that of a voluntary muscle. Similarly, while the period of contraction of the

pulvinus of *Mimosa* is about 1.5 second, that of the rhythmic pulvinule of *Desmodium* is very much longer, *i.e.* about 45 seconds.

Experiment 156.—In order to study in detail the time-

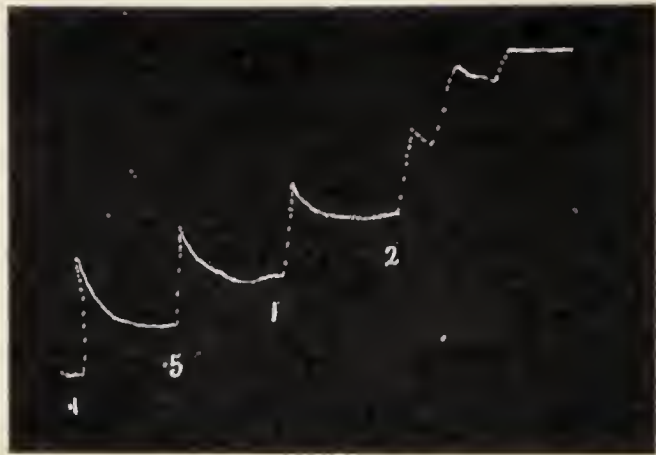

FIG. 149. Response of *Biophytum* leaflet to stimulations of 0.1, 0.5, 1, and 2 minutes.

Response is seen to become multiple with the last.

relations of a single pulsation of *Desmodium*, I applied an induction-shock to the quiescent leaflet and took the record



FIG. 150. Single response of *Desmodium* leaflet.
Successive dots at intervals of 1 second.

of response on a fast-moving plate. The frequency of oscillation of the recording-plate was once in a second, hence successive dots represent that interval of time. The complete response, consisting of the contractile fall of the leaflet

and subsequent recovery, was accomplished in the course of 2 minutes and 45 seconds; the leaflet attained its maximum systolic contraction, shown by the up-curve, 45 seconds after the application of the stimulus. The top of the response curve appears flat, indicating a persistent contraction from which the recovery is relatively slow. The period of diastolic expansion was about 120 seconds (fig. 150).

THE REFRACTORY PERIOD

That the characteristics of the response of the rhythmic tissue of *Desmodium* are similar to those of the rhythmic cardiac tissue of the animal is demonstrated by the following

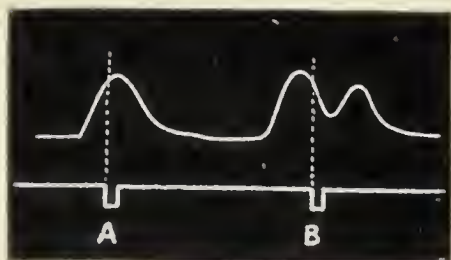

FIG. 151.

FIG. 151. Stimulus applied at systolic phase A produced no effect on cardiac pulsation.

An extra pulsation was induced by stimulation during diastole B. [Heart of Frog.]

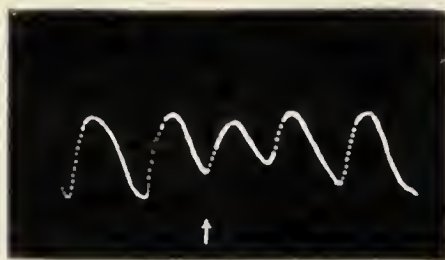

FIG. 152.

FIG. 152. Extra pulsation of *Desmodium* under stimulation ↑ at diastole.

experiments. In the cycle of the heart-beat there is a *refractory period* during which the tissue takes no account of the stimulus, or is refractory to it; this refractory period lasts throughout the period of systolic contraction; the irritability begins to be restored during diastole, the maximum excitability being attained after the completion of diastolic recovery. The restoration of excitability is shown by an extra-contraction produced by stimulation applied at any period of diastole (fig. 151).

The pulsation of *Desmodium* exhibits similar characteristics as shown by the following experiment.

Experiment 157.—The application of electric stimulus during contractile systole was found to have practically no effect on the pulsation. But the application of an induction-shock during diastolic expansion not merely arrested the expansion but caused contraction and an extra pulsation (fig. 152).

CAUSE OF RHYTHMICITY

The response of a rhythmic tissue to continuous external or internal stimulation is not a continuous contraction, but repeated contractions of a pulsatory nature. The explanation of this is to be found in the 'refractory period' of the tissue. After each discharge, the excitability disappears for a time, to become slowly restored for the second and subsequent responses. There is thus an oscillatory variation in the excitability of the tissue. A physical model will help in visualising the process of rhythmic response. Imagine a reservoir into which flows a constant supply of water; the elastic overflow-pipe is constricted by a compressing spring. On the far end of the pipe abuts the flat end of the indicating lever. Constant supply of water raises the level in the reservoir; when the pressure of the water-column becomes sufficiently great, the spring which keeps the elastic tube constricted gives way and there is an impulsive discharge of water, producing a responsive movement of the indicating lever. The yielding spring closes again, and the tube becomes once more constricted with cessation of outflow. On account of the oscillating mechanism, the outflow and consequent mechanical response are periodic, though the supply is constant. It is clear that a rhythmic series of effects, such as pulsatory responses, need not have a periodic antecedent cause. The stored energy is discharged in a rhythmic manner by the periodic change of excitability caused by the refractory period.

The energy which expresses itself in pulsatory movement is ultimately derived from external sources of stimulation. The persistence of pulsatory activity after the

cessation of external stimulation depends on the capacity for storage. Certain tissues have but small capacity and the after-effect is short-lived ; in other cases, the capacity for storage is large, and the pulsatory activity persists for a very considerable length of time.

SEMI-AUTOMATISM

The plant is exposed under natural conditions to the action of various stimuli, supplied by its environment. It is subjected to variation of temperature, to the action of light, to the mechanical stimulus of air-currents, and to the action of various chemical agents present in it or absorbed by it. From the joint action of these sources of stimulation, the tonic condition is raised above the optimum with resulting excitatory overflow. Thus, on a warm and sunny day, a particular leaflet of *Biophytum* may have been moved by a puff of wind, or by the alighting of a small insect, or by the accidental touch of an adjacent blade of grass. The excitation thus initiated in the super-tonic tissue is enough to set all the leaflets of the plant quivering in an extraordinarily lively manner. The origin of the impulse can be traced in some cases, but not in others which therefore appear as spontaneous. In *Mimosa*, growing in the open, but under glass, I have on many occasions noticed seemingly spontaneous activity by which the leaflets underwent a rippling closure, followed by the fall of the leaf. The effect was observed when the plant was in a highly excitable condition.

The results described prove that there is no rigid line of demarcation between multiple and automatic response. An ordinary responding plant, like *Biophytum*, which gives a single response to a feeble stimulus, and multiple responses to a moderate stimulus, passes into an automatically pulsating condition by absorption of excess of energy from without. *Desmodium*, with its pronounced automatic activity, becomes reduced to the condition of an

ordinarily responding plant by depletion of its store of energy; the tissue in this subtonic condition gives a single response to a single moderate stimulus, and multiple responses to a strong stimulus. Biophytum is thus equivalent to a *Desmodium* brought to a state of standstill by depletion of its store of energy; and *Desmodium* to a *Biophytum* with an excess of stored energy.

SUMMARY

The automatic rhythmic activity of the leaflet of *Desmodium* comes to an end when its store of energy is exhausted after isolation from the stimuli of its normal environment.

In this state of standstill, response occurs under fresh stimulation; a feeble stimulus gives rise to a single response, while a strong stimulus causes a series of multiple responses.

An intermediate link between ordinary and automatic response is found in the multiple response exhibited by *Biophytum*, *Averrhoa*, and other plants. These give a single response to a feeble, and a recurrent series of responses to a strong stimulus.

Multiple responses, mechanic or electric, are induced by various modes of stimulation, such as electric shock, light, thermal shock, and chemical excitation.

The rhythmic character of the response is brought about by a periodic variation of excitability, due to the refractory period of the tissue.

There is no strict line of demarcation between the phenomena of multiple and of automatic response. Under favourable conditions for absorption of energy from without, an ordinarily responding plant like *Biophytum* becomes converted into an apparently automatically moving plant like *Desmodium*. Conversely, under unfavourable circumstances brought about by isolation from the stimuli of its normal environment, the leaflets of an automatically responding plant like *Desmodium* come to a state of

standstill ; it then becomes converted into an ordinarily responding plant like *Biophytum*.

In this state of standstill the *Desmodium* leaflets respond to stimulus in exactly the same way as do those of *Biophytum*. To feeble stimulation they respond by a single pulsation ; strong stimulation causes a series of multiple responses in both.

The duration of multiple activity depends on the amount of energy absorbed from external stimulation. The persistence of this after-effect depends on the greater or lesser capacity of the tissue for storage of energy.

Automatic or spontaneous pulsation is therefore not self-originated, but is really due to the previous absorption of energy from the stimuli of the environment.

CHAPTER XX

RHYTHMIC MECHANISM IN PLANT AND ANIMAL

THE automatic pulsation of the leaflet of *Desmodium gyrans* has been described in the previous chapter. The question which will now be discussed is whether the rhythmic mechanisms in the plant and the animal are essentially similar or widely different. For successful investigation of the subject it was necessary to devise recording appliances of great sensitiveness and accuracy, and to adopt new methods of experimentation.

THE RESONANT CARDIOGRAPH

The oscillating device for recording the pulsation of the leaflet of *Desmodium* has already been described ; the error due to friction is completely removed by the method of the dotted record ; the record itself, moreover, gives the time-relations of the different phases of the pulsation. The record of the pulsation of the animal heart by the lever-recorder, the cardiograph, labours under the serious disadvantage of the continuous frictional contact, a source of error in the accurate record of the amplitude and time-relations of the heart-beat. The drawback of continuous contact is eliminated in my Resonant Cardiograph (fig. 153), which records the pulsations with great precision by a series of periodic dots, the cardiogram being also its own chronogram. The great advantage of the intermittent over the continuous contact is illustrated by two records of pulsation of an identical heart, in which the lower was taken with

continuous, and the upper with intermittent contact (fig. 154). The continuous-contact record is irregular on account of the slight variation of the friction at different parts of the recording surface; the intermittent record, on the other hand, exhibits a very remarkable regularity. The phasic alternations of the heart-beat are thus recorded by the Resonant Cardiograph with unprecedented accuracy. The systolic contraction and its persistence, the diastolic

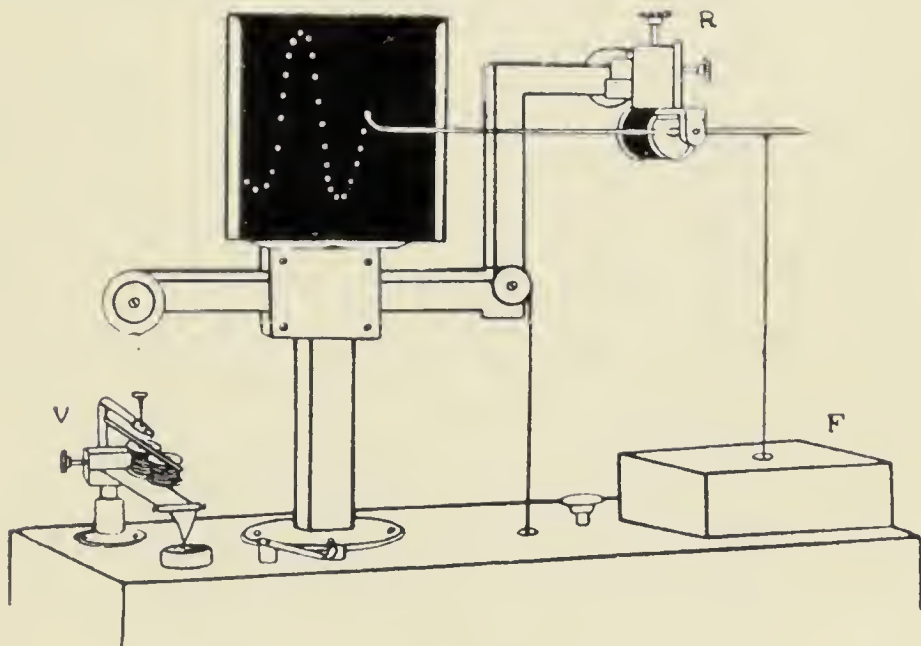

FIG. 153. The Resonant Cardiograph.

R, the lever-recorder set in resonant vibration by the intermittent current produced by the vibrating reed V. F is the Frog chamber.

expansion and the subsequent pause, and variations of these under external agencies, can thus be determined in a quantitative manner.

Experiment 158. *Cardiogram of different animals.*—As an example of the advantage of the automatic registration of extremely short intervals of time in diverse investigations, I reproduce the cardiograms of different animals: those of the tortoise, of the frog, and of a fish (*Ophiocephalus*) (fig. 155). The resonant writing-lever was tuned to vibrate 20 times in a second, the magnification employed being about

8 times. The time-relation is indicated by the intervals between successive dots which are $\frac{1}{20}$ second apart. The record shows the auricular contraction preceding the ventricular. The period of a complete cycle is longest in the tortoise, the total period being 34 dot-intervals, or 1.7 second. The record of the frog's heart gave 14 dot-intervals or 0.7 second,

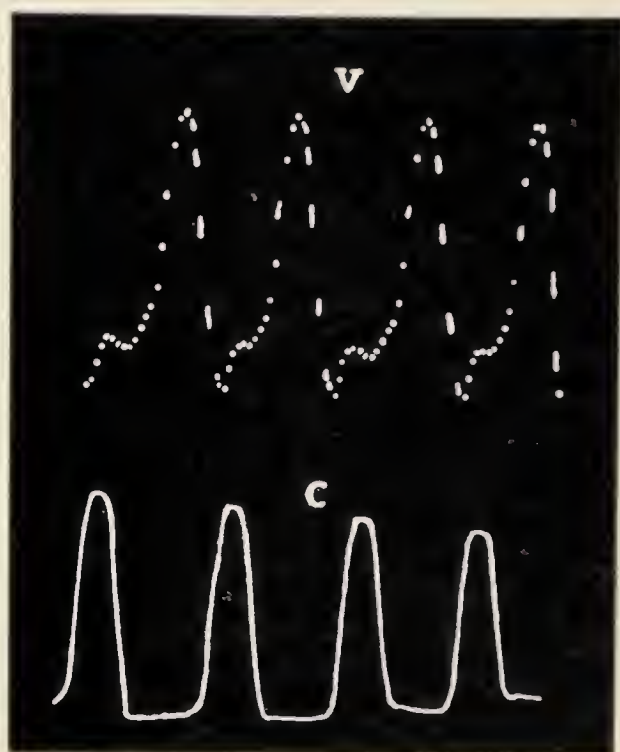

FIG. 154. Irregular record of heart-beat of Frog due to unequal friction in the continuous contact (lower record c), compared with the regular record with intermittent contact (upper record v).

while in the fish the period was 16 dot-intervals or 0.8 second. In the tortoise, after the commencement of the less pronounced systolic contraction of the auricle, the peristaltic contractile wave reached the ventricle in the course of 0.6 second, whereas in the frog and in the fish the interval was only 0.2 second, or one-third that in the tortoise. Other records give very striking visual demonstration of the relative activities at different phases of the pulsation. When the activity is very great, the markings are wide

apart, and the dots are lengthened into dashes; with the slowing down of activity, the dots become reduced in

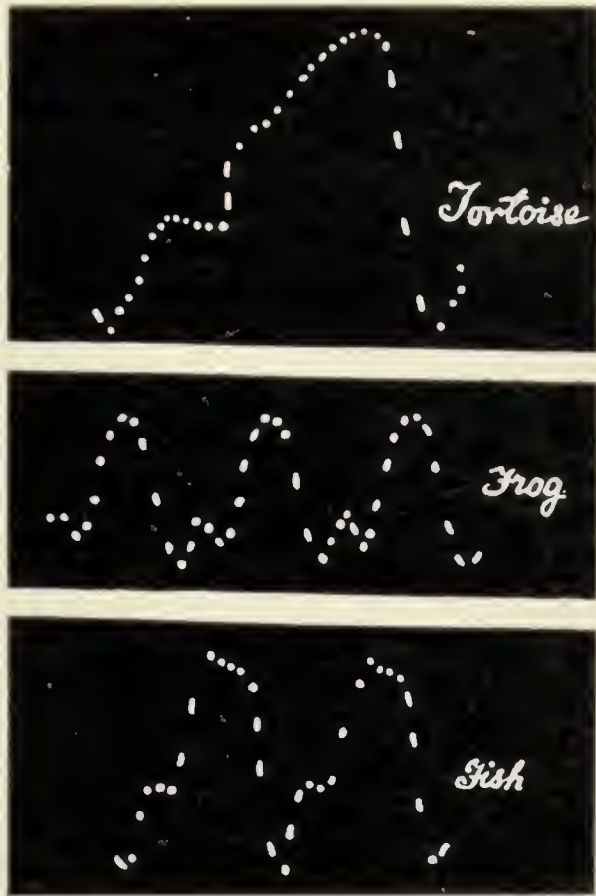

FIG. 155. Characteristic cardiograms of Tortoise, Frog, and Fish.
The dot-intervals represent 0.05 second.

size and are drawn close together. Under the action of depressing agents, the post-diastolic pause becomes greatly prolonged.

THE EXPERIMENTAL METHOD

I now turn to the various difficulties that are encountered in the accurate investigation of the effects of various agents on cardiac activity, and the new method by which they have, to a great extent, been removed. In the study of induced variation of cardiac activity, the nearest approach to the normal condition is secured when the heart instead of being detached is left *in situ*. But the

application of external agents on the mass of the heart now becomes extremely difficult. For example, in the study of thermal reactions, it is impossible to vary the temperature of the mass of the heart as a whole with any degree of accuracy. Similar difficulty is encountered in the study of the action of drugs injected into the circulatory system. The responsive variation is not merely delayed but also modified by the size of the animal.

I therefore sought to discover an alternative method which would, in a large number of cases, demonstrate in the course of a few seconds the specific reaction of a particular drug or the physiological antagonism produced by a suitable antidote. Various attempts made in this direction led me to realise the important part played by the sinus in the cardiac rhythm. The different parts of the heart exhibit a descending scale of automatic activity, that of the sinus being the highest, whereas it is lowest in the ventricle. It thus happens that the normal sequence of beat is always sinus, auricle, and ventricle, the highly automatic sinus giving the signal, as it were, for the rest. Any variation induced in the activity of the sinus is thus recorded by the auricle-ventricle, which may be regarded as a convenient indicator. The results given in the course of this chapter will show how many difficulties of investigation have been effectively removed by the local application of various agents on the small area of the sinus.

Before proceeding further, brief reference should be made to the rival theories of the origin of the rhythmic activity, whether nervous or muscular, of pulsating tissues.

NEUROGENIC AND MYOGENIC THEORIES

The neurogenic theory assumes that the rhythmic impulses are generated by ganglion cells. This theory of the ganglionic origin of cardiac rhythm has been adversely affected by the researches of Gaskell and of Engelmann¹:

¹ Starling—*Principles of Human Physiology*, p. 984.

- (1) It has been found that the heart in the developing chick begins to beat at a time when it is quite devoid of nerve cells, which only extend to it at a later date.
- (2) The ventricle of the tortoise exhibits rhythmic contractions, though it contains no ganglion cells.
- (3) The rate of conduction of the excitation in the heart is slow, like that in a muscle, and not quick as in a nerve.

The cardiac rhythm is therefore *myogenic* and not *neurogenic*. The normal rhythm can, however, be modified by transmitted nervous impulses.

RHYTHMIC ACTIVITY OF ISOLATED PULVINULE OF DESMODIUM

It may similarly be asked concerning the rhythmic pulsation of the *Desmodium* leaflet: Is it due to periodic nervous impulses coming from the conducting tissue in the petiole, or to automatic contraction of its motor or muscular tissue? In order to demonstrate the independent rhythmic power of its motor organ, the pulvinule was isolated for investigation. The pulvinule is excessively small, being 2 mm. in length and 0.3 mm. in diameter. It had to be magnified 4 times to be shown clearly (right-hand lower corner of fig. 156). Would the pulvinule continue to pulsate after isolation; and if so, would it be possible to record movements of an organ so minute and slender? In pursuit of this investigation I utilised the leaflet *l* as a convenient handle, which was clamped within a silver spring *s* coated with solid paraffin. The pulvinule *p* was held horizontal with the lower side downwards. A cocoon-thread attached the free end of the pulvinule to the recording-lever, the inscription being made on a moving oscillating plate of smoked glass. The whole arrangement was made extremely delicate and sensitive, though I entertained little hope of success in detecting any pulsation of the isolated

pulvinule. The remarkable records of pulsation surpassed my most sanguine expectations. This new method of

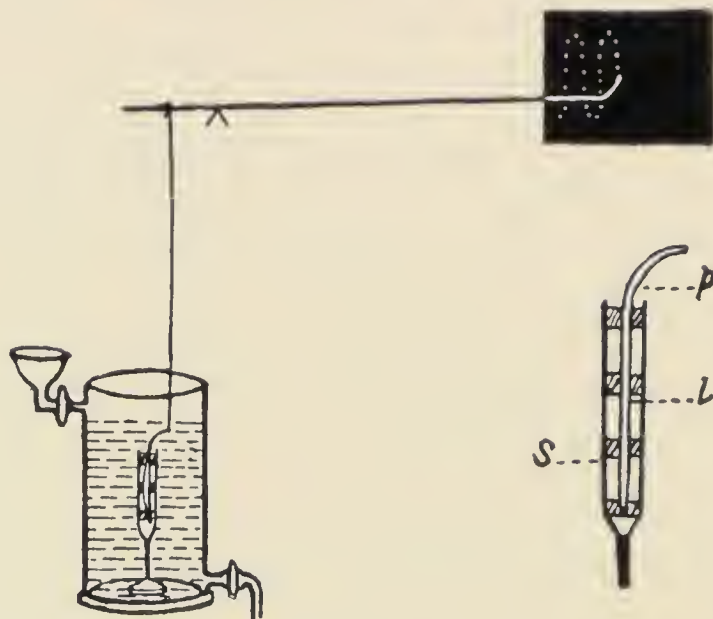

FIG. 156. Diagrammatic representation of Recorder for the pulvinule of *Desmodium*.

The isolated pulvinule, magnified 4 times, is seen in the lower right-hand figure: *l*, leaflet; *s*, silver spring; *p*, pulvinule.

experimentation with the isolated pulvinule offered unique advantages in several investigations to be presently described.

CHARACTERISTIC FEATURES OF RHYTHMIC ACTIVITY

I return to the question raised at the beginning of this chapter, whether the rhythmic mechanism is essentially the same in the animal and in the plant. What are the various features by which all automatic activities are distinguished? These have been studied in the case of the rhythmic activity of the animal heart. The various characteristics of the automatic pulsation of the cardiac tissue are :

- (1) The heart-beat is depressed or comes to a stop when the internal tension or pressure is low, the pulsation being revived by a suitable increase of intra-cardiac pressure.

- (2) In addition to the store of energy in the form of complex organic substance, a supply of oxygen is necessary for the catabolic process of evolving energy for the maintenance of pulsatory activity.
- (3) The effect of external stimulation is modified by its intensity and by the tonic condition of the tissue.
- (4) Temperature has a marked effect on its rhythmic activity. Rise of temperature increases the frequency of pulsation ; lowering of temperature, on the other hand, slows down and finally arrests the pulsation at a thermometric minimum.
- (5) The cardiac activity is modified in a characteristic manner by the specific action of various anaesthetics and drugs.

These different criteria will be employed to estimate the characteristics of rhythmic pulsations, first of the pulvinar tissue of *Desmodium* and later of that in the interior of the plant.

EFFECT OF VARIATION OF INTERNAL PRESSURE

It has been stated that a certain amount of internal tension or pressure is necessary for the maintenance of the

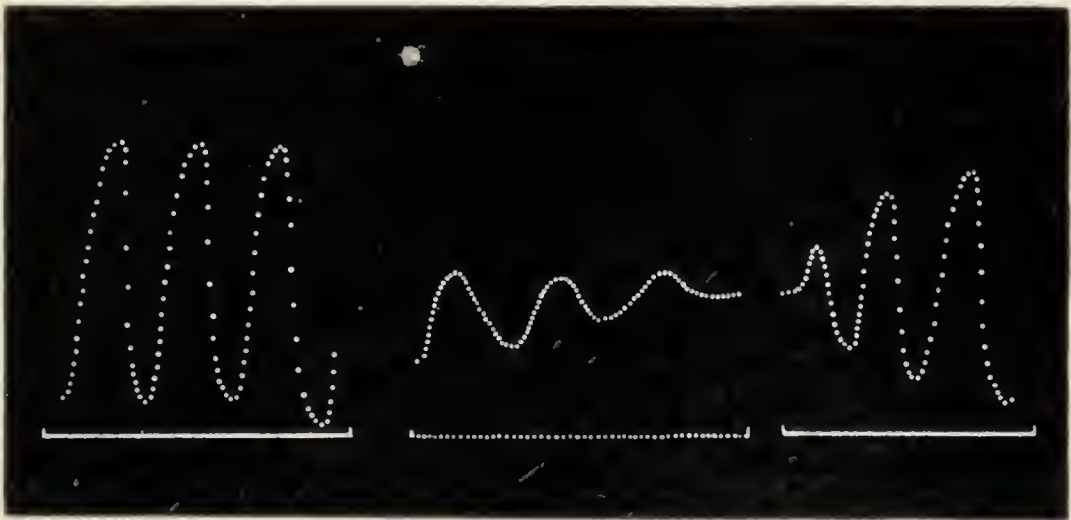

FIG. 157. Effects of drought and irrigation on pulsation of *Desmodium*.

The first series exhibits normal pulsation ; the second, arrest under drought ; the third, revival caused by irrigation.

rhythmic pulsation of the animal heart. Thus the quiescent heart of the snail is made to pulsate by subjecting it to an increased intra-cardiac pressure. A similar effect has been observed in the plant.

Experiment 159.—A petiole of *Desmodium* carrying the two leaflets was suitably mounted in a U-tube filled with water and the normal record taken by the Oscillating Recorder. On ceasing the supply of water the pulsations underwent arrest on account of diminished internal pressure caused by drought ; reapplication of water caused increased turgor and pressure with revival of pulsation (fig. 157).

OXYGEN NECESSARY FOR MAINTENANCE OF PULSATION

Experiment 160.—The isolated pulvinule of *Desmodium* in air gave pulsations which after persisting for a time came to a stop on account of the drying up of the pulvinule. Another pulvinule was kept immersed in water ; its pulsations, however, came to a stop after a while. The question arises : To what was this arrest of pulsation due ? It may be thought that one of the probable factors in producing arrest was the abnormal condition in which the pulvinule was placed, namely, immersion in water. There was, in reality, another and more important factor, namely, deprivation of oxygen, the amount contained in water being liable to exhaustion after a short time. The importance of oxygen will be realised from the following experiment.

Experiment 161. *Effect of supply of oxygen on arrested pulsation.*—The arrest of pulsation of the pulvinule immersed in water is exhibited by the short horizontal portion at the beginning of the record (fig. 158). I now added oxygenated water to the water in which the pulvinule had come to a state of standstill. The result was an immediate revival of pulsation. This affords conclusive proof of the importance of oxygen in the maintenance of rhythmic activity. A simple way of supply of oxygen is

to add a few drops of highly diluted hydrogen peroxide to the water in which the pulvinule is immersed.

Experiment 162. *Asphyxiating action of CO₂*.—In continuation of the last experiment, CO₂ water (so-called

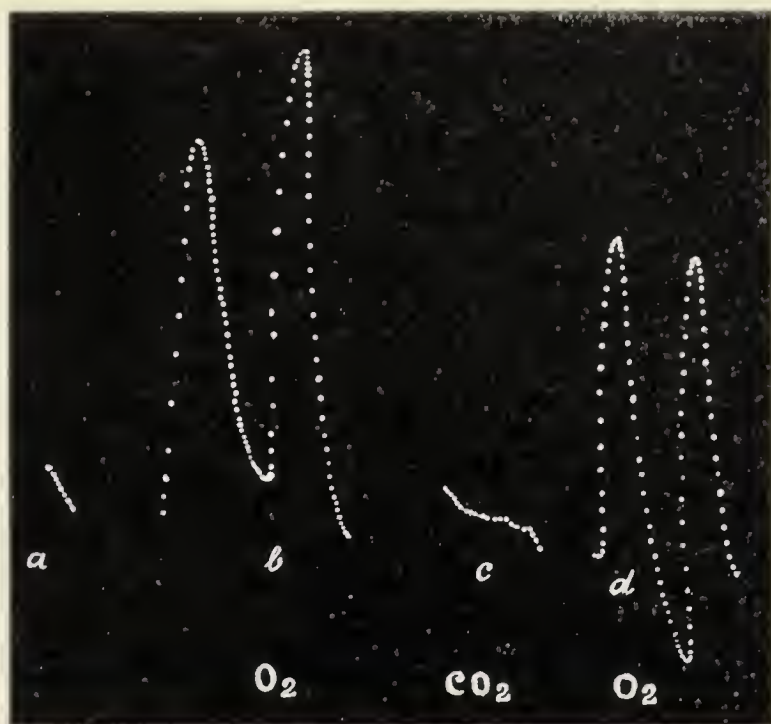

FIG. 158. Effects of oxygen and carbonic acid gas in reviving and arresting pulsation of *Desmodium* leaflet.

The horizontal record *a*, at beginning, shows arrest of pulsation from lack of oxygen, supply of which revived it in *b*. Substitution of carbonic acid water arrested the pulsation in *c*. Fresh application of oxygenated water revived pulsation at *d*.

soda-water) was substituted for water containing oxygen. This produced a quick arrest of pulsation. Water containing oxygen was next applied, with resulting revival of pulsation (*see* last two records, fig. 158).

CONSUMPTION OF OXYGEN DURING CARDIAC ACTIVITY

The consumption of oxygen by the pulsating heart is demonstrated by the well-known experiment showing that the blood contains less oxygen after passing through the

heart than when it entered it. The following experiments which I devised will prove interesting. In repeating with the heart of the frog experiments parallel to those with *Desmodium* (Experiment 162), I first observed the effect of CO_2 and afterwards that of oxygen.

Experiment 163. *Effect of CO_2 on frog's heart-beat.*—A record N (fig. 159) was taken of the normal heart-beat.

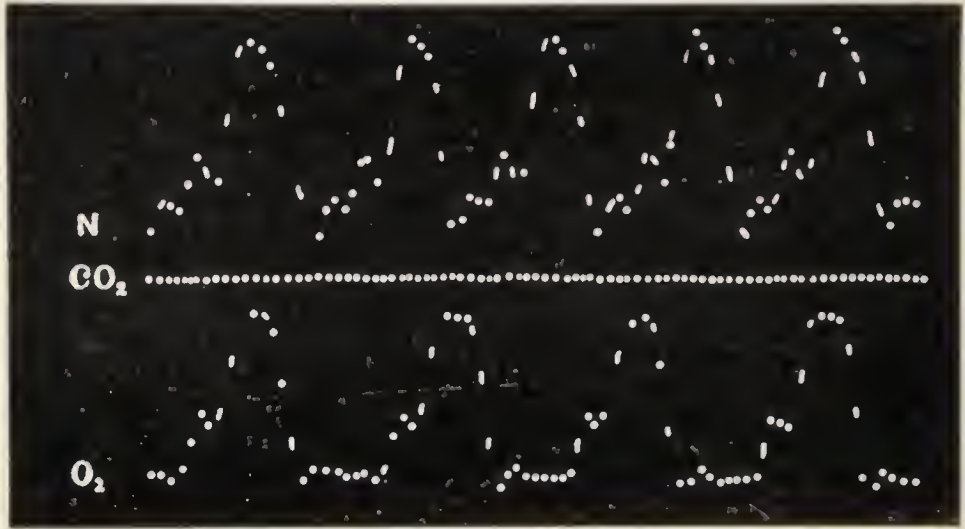

FIG. 159. Arrest of normal heart-beat of Frog under the action of CO_2 , and its subsequent revival by oxygen, shown in three records.

N, normal pulsation of heart; CO_2 , inhibition under CO_2 ; O_2 , revival on fresh supply of oxygen.

CO_2 water was next applied on the sinus by means of a pipette; this produced an arrest of pulsation in the course of about 30 seconds. Vigorous specimens necessitated a longer application for bringing about complete arrest.

Experiment 164. *Revival of arrested pulsation by supply of oxygen.*—The middle record of fig. 159 shows the arrest under CO_2 . Application of oxygenated water on the sinus resulted in the complete revival of pulsatory activity as shown in the third and lowermost series.

MODIFYING EFFECT OF TONIC CONDITION ON RESPONSE TO
EXTERNAL STIMULATION

I will next show how the effect of external stimulation is modified by the tonic condition of the pulsating tissue, describing first the effect on the heart.

Effect of strong stimulation on vigorous heart-beat.—Intense stimulation has an inhibitory effect on vigorous pulsation. The effect of stimulation on the heart in a subtonic condition is, however, very different; it enhances the activity

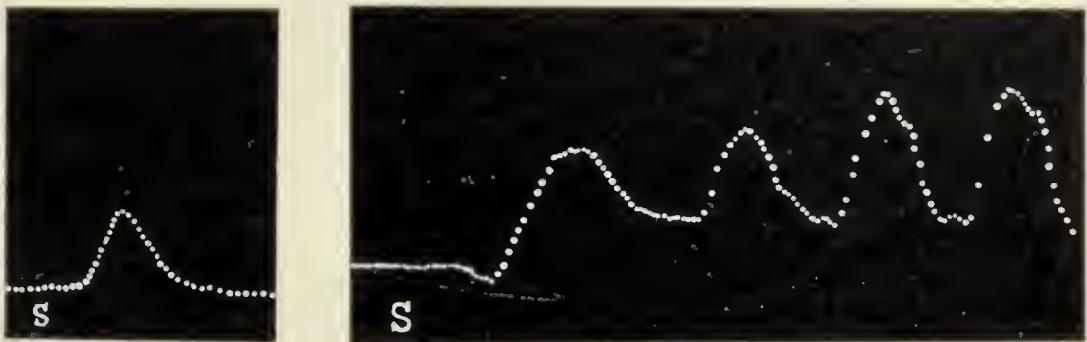

FIG. 160. Revival of Frog's heart-beat by feeble and by strong electric stimulation.

Feeble stimulation gave rise to a single response seen at the beginning of record; subsequent series of multiple responses are due to stronger stimulation.

when the pulsations are feeble and renews the pulsation when the heart is in a state of standstill.

Experiment 165. *Effect of moderate stimulation on heart at standstill.*—The heart after isolation gradually came to a state of standstill. Stimulation was then found to revive the pulsation. The heart can, moreover, be stopped by Stannius' ligature. A single moderate stimulation then produces a single pulsation.

Experiment 166. *Effect of stronger stimulation.*—The effect of moderately strong stimulation on the heart brought to standstill by Stannius' ligature is shown in the series of multiple responses (fig. 160). Parallel effects were observed with the leaflet of *Desmodium* (cf. Experiments 146, 147).

[Experiment 167. *Effect of strong direct stimulation on vigorous pulsation of Desmodium.*—The normal pulsation becomes inhibited by strong electric stimulation ; there is

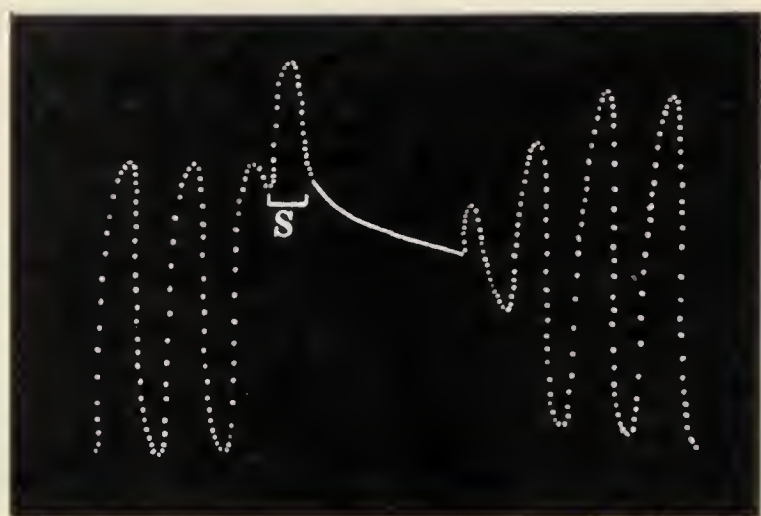

FIG. 161. Effect of strong direct electric stimulation at s : temporary arrest of Desmodium pulsation.

often a revival on the cessation of stimulation, the amplitude of pulsation being even greater than the normal (fig. 161).

Experiment 168. *Effect of strong indirect stimulation on Desmodium pulsation.*—The petiole carrying the leaflet was

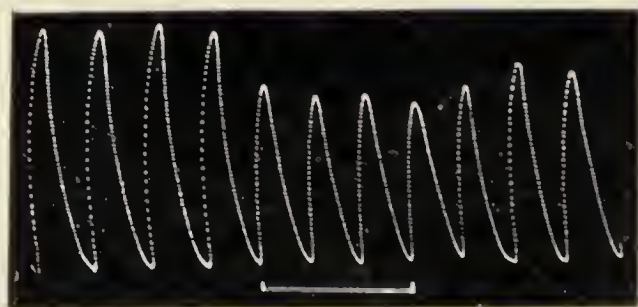

FIG. 162. Effect of strong transmitted excitation in depressing pulsatory activity in a vigorous specimen.

Note the gradual removal of inhibitory effect on cessation of stimulation.

subjected to strong electric stimulation ; this had an inhibitory effect, as shown by the diminution of the amplitude of pulsation (fig. 162).

The effect of stimulation in reviving pulsation of the *Desmodium* leaflet has already been given in the previous chapter (*cf.* figs. 143, 144). I describe below the effects of direct and indirect stimulation on feeble pulsation.

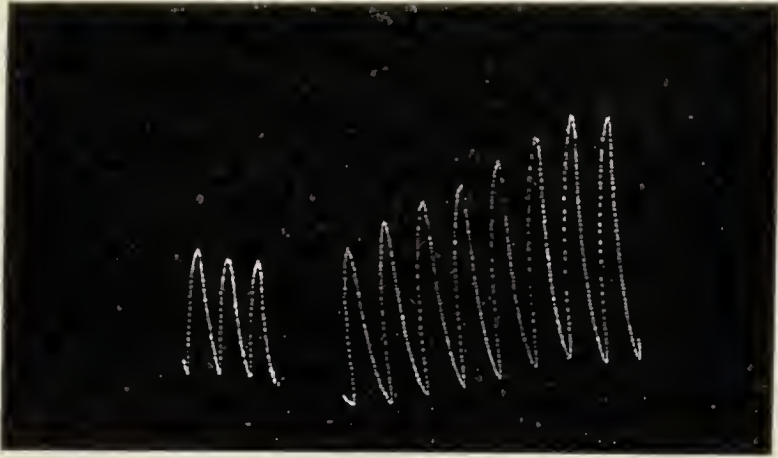

FIG. 163. The feeble automatic pulsation in dark enhanced after stimulation by light.

Experiment 169. *Effect of direct stimulation on feeble pulsation of Desmodium.*—The specimen was kept for a time in the dark with resulting enfeeblement of activity due to lowering of its tonic condition. Direct exposure to the

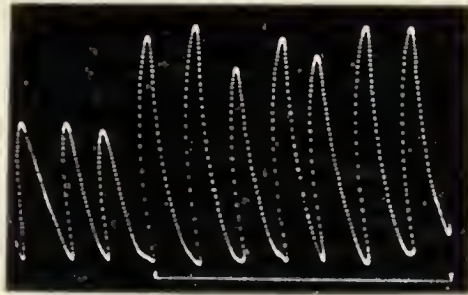

FIG. 164. Transmitted effect of moderate and indirect electric stimulation enhancing the pulsatory activity of *Desmodium* in a subtonic condition.

stimulus of light caused a great increase of pulsatory activity (fig. 163).

Experiment 170. *Effect of indirect stimulation on feeble pulsation.*—The leaflet was in a subtonic condition and its pulsatory activity was feeble. Electric stimulation of

moderate intensity was applied on the petiole bearing the leaflets. The transmitted excitation caused an enhancement of the pulsatory activity (fig. 164).

The important result established is that *while stimulation inhibits pulsation in a vigorous specimen, it revives or enhances it in a subtonic specimen. Two opposite effects are thus produced which depend on the tonic condition of the tissue.*

EFFECT OF VARIATION OF TEMPERATURE ON PULSATION OF DESMODIUM LEAFLET

I have in a previous work ¹ described the effect of variation of temperature on summer-specimens of *Desmodium*. The results were that the pulsation of the leaflet became slowed down and finally arrested at a thermometric minimum which was about 17.5° C. Rise of temperature, on the other hand, increased the frequency of pulsation; at a temperature of about 42° the frequency was increased, but the amplitude became so small that the pulsations appeared to have come to a stop. This was by no means due to coagulation of protoplasm and death of the plant; for subsequent lowering of temperature by a few degrees caused an immediate revival of pulsatory activity.

The method previously employed for raising the temperature of the leaflet was to enclose it in a moist chamber, the temperature of which was gradually lowered by blowing in cooled air, or raised by electric heating. But it was impossible to be certain whether the tissue in the interior of the semi-conducting plant acquired the temperature of the chamber. The only certain way of ensuring definite thermal variation of the tissue is to immerse the specimen in a water-bath (*cf.* fig. 156), the temperature of which can be accurately adjusted.

The method of obtaining a record of the pulvinule immersed in water has the advantage that a stream of

¹ *Irritability of Plants* (1913), p. 326.

cooled or warmed water can be passed through the vessel, and records taken at different temperatures. I also wished, in this connexion, to determine the effect of the temperatures to which the plant had been habituated at different seasons of the year. In winter the minimum temperature in Calcutta is about 15° C., while in summer it is 22° C.

Experiment 171. *Determination of the thermometric minimum in a winter-specimen.*—The record was commenced

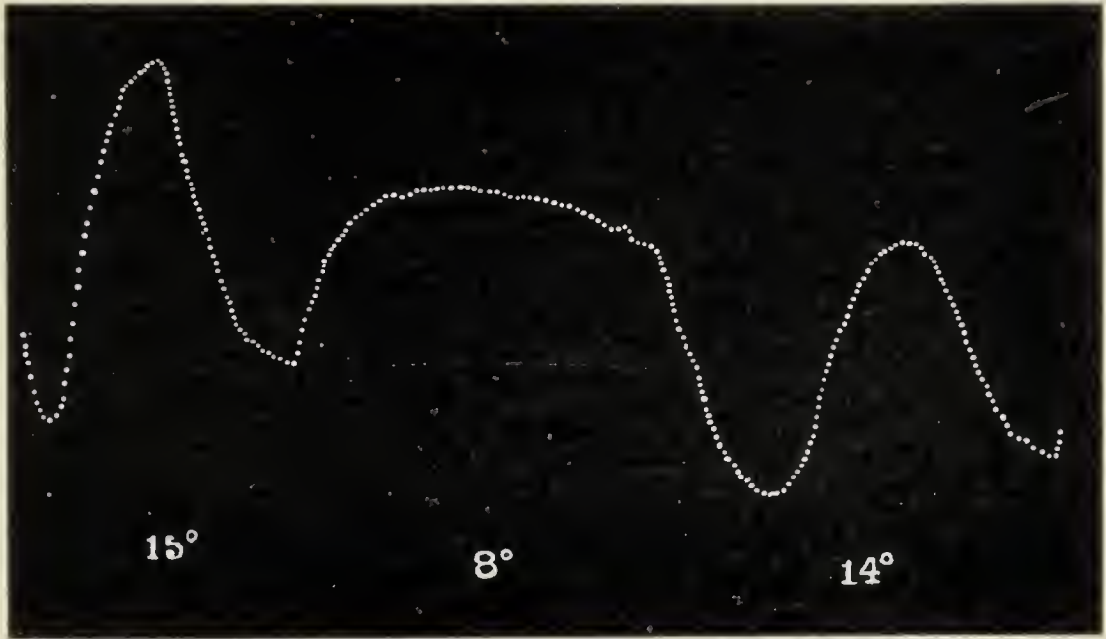

FIG. 165. Effect of cooling in arresting the pulsatory activity of *Desmodium gyrans*.

Note that the thermometric minimum was at or about 14.5° C.

at 15° , and cooled water passed through the bath, which reached the temperature of 8° . Long before this, pulsation had become arrested. The bath was then allowed to reach the temperature of the room, and the pulsation began to be revived at 14° (fig. 165). The thermometric minimum of the particular winter-specimen may therefore be taken as the mean of 15° and 14° , *i.e.* 14.5° , in contrast with 17.5° which is the minimum for a summer-specimen.

Experiment 172. *Effect of variation of temperature from 23° to 40° .*—The automatic record given by the plant

(fig. 166) gives a vivid representation of the variation of pulsatory activity. At 23° the amplitude of pulsation was very large, the period of a single pulsation being 4.75 minutes. At 28° the period of each pulsation had become shortened to 2.4 minutes, which means an increase of frequency of pulsation. The amplitude had decreased, but

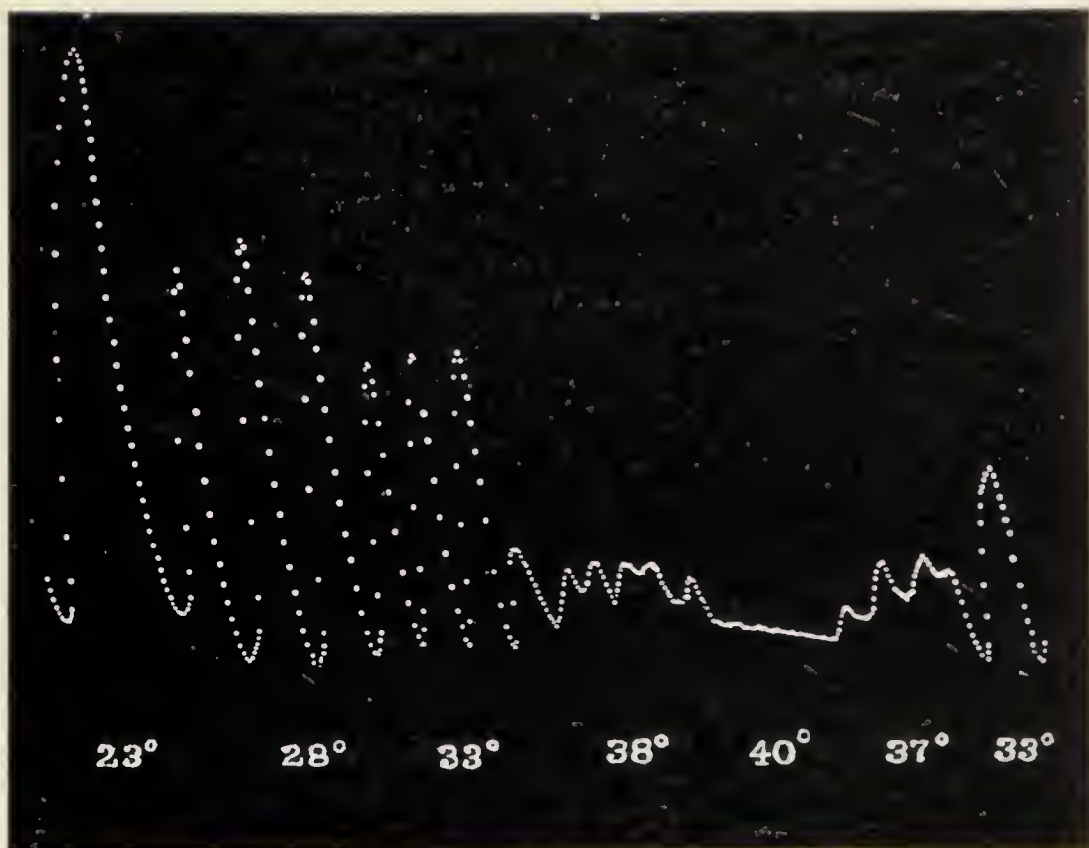

FIG. 166. Effect of rise of temperature in increasing frequency of pulsation (*Desmodium*).

Pulsation temporarily arrested at 40° C. and revived at 37° C.
Successive dots at intervals of 5 seconds.

this must not be taken as an indication of depression of activity; it is due to the quickening of the rate which did not allow time for complete expansion or contraction. At 38° the period was further shortened to 1.25 minute; at 40° the amplitude was so reduced that the pulsation appeared to be arrested. That the pulsation did not undergo any permanent arrest is clear from the fact that on lowering the temperature to 37° there was an immediate revival of pulsation.

I give below a table showing the effect of variation of temperature on the period and frequency of pulsation.

TABLE XV.—EFFECT OF VARIATION OF TEMPERATURE ON PULSATION OF DESMODIUM LEAFLET.

Temperature	Period of each pulsation	Frequency per hour
23° C.	4.75 minutes	12.7
28° C.	2.4 ,,	25.0
33° C.	1.8 ,,	33.3
38° C.	1.25 ,,	48.0
40° C.	Apparent stoppage	
37° C.	1.4 minute	43.0

EFFECT OF VARIATION OF TEMPERATURE ON HEART-BEAT

Accurate determination of the effect of variation of temperature on the frog's heart *in situ* is, as previously stated, a matter of extreme difficulty. This has been overcome, in the majority of cases, by the following experimental device.

I have explained that the effect of external agencies on the heart can be studied by subjecting the sinus alone to changing external conditions.

Experiment 173.—A stream of normal saline at different temperatures is projected on the sinus and on a sensitive thermometer placed on its side. The variation of temperature of the sinus can thus be ascertained with great accuracy.

The record of the heart-beat was taken at the attainment of a steady temperature. The experiment was commenced at 0° C., at which the pulsation was arrested. It became feebly renewed at 5° C. and more pronouncedly revived at 10° C. The period of each pulsation became shorter with the rise of temperature. At 5° C. the period was 3 seconds; at 10° C., 2.8 seconds; and at 15° C., 2.1 seconds. Rise of temperature thus caused a shortening of the period, that is, increased its frequency. Thus the frequency of pulsation

at 5° was 20 per minute; at 10° , 21.4; at 15° , 28.5; at 22° , 54.5; at 30° , 75; at 35° , 80; and at 45° , 100. It is remarkable that the pulsation persisted even at 45° ,

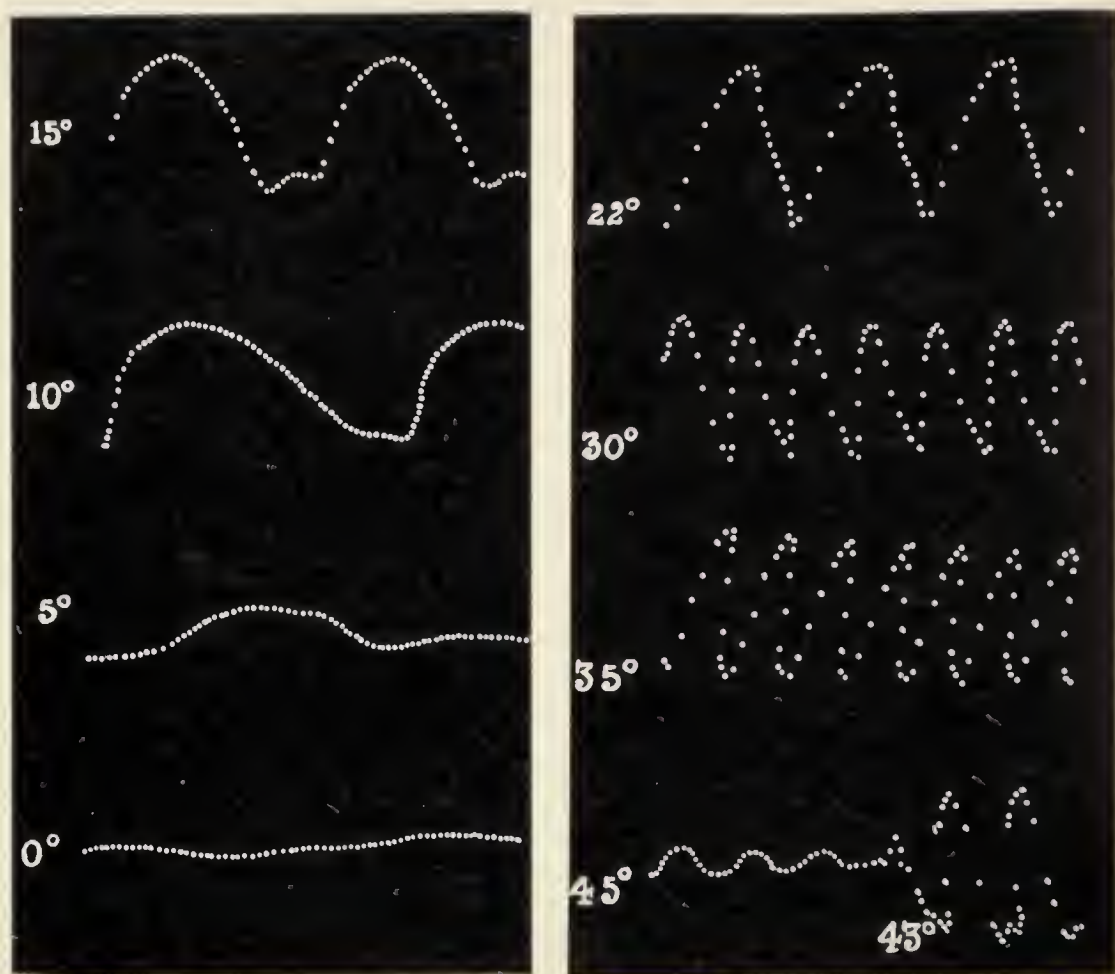

FIG. 167. Effect of rise of temperature in enhancement of frequency of heart-beat (Frog).

Records to be read from below upwards for 0° to 15° , and downwards for 22° to 45° . Note small amplitude of pulsation at 45° , increased on fall of temperature to 43° C.

though with reduced amplitude. When the temperature was lowered to 43° the amplitude became immediately increased (fig. 167). A somewhat parallel effect was observed with *Desmodium* (*cf.* fig. 166).

The following table gives the period and frequency of pulsation per minute.

TABLE XVI.—EFFECT OF VARIATION OF TEMPERATURE ON HEART-BEAT OF FROG.

Temperature in degrees	Period of pulsation in secs.	Frequency per minute
0	Arrest	Arrest
5	3.0	20.0
10	2.8	21.4
15	2.1	28.5
22	1.1	54.5
30	0.8	75.0
35	0.75	80.0
45	0.6	100.0

EFFECT OF CHEMICAL AGENTS ON CARDIAC AND DESMODIUM PULSATION

It is known that certain chemical agents induce characteristic modifications of the cardiac activity. Experiments described below show that their effects on the pulsatory activity of *Desmodium* leaflet are essentially similar.

Experiment 174. *Stimulating action of Spiritus Ammoniae Aromaticus on heart-beat*—The effect is clearly seen

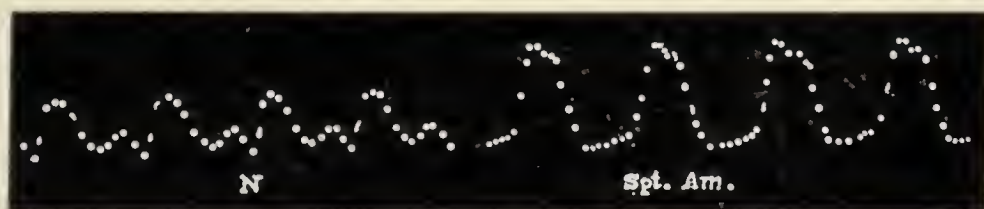

FIG. 168. Stimulating action of Spirit. Ammon. Arom. on heart-beat of Frog.

in a pair of records given in fig. 168. The normal heart-beat was extremely feeble. But application of the drug caused a great increase in the amplitude of pulsation.

Experiment 175. *Stimulating action of Spirit. Ammon. Arom. on Desmodium pulsation*.—The isolated pulvinule was immersed in water and its normal record taken; a few drops of the drug were then added to the water. This caused a marked increase in the amplitude of pulsation (fig. 169).

Experiment 176. *Effect of Potassium Bromide solution on Desmodium pulsation.*—Being under the impression that

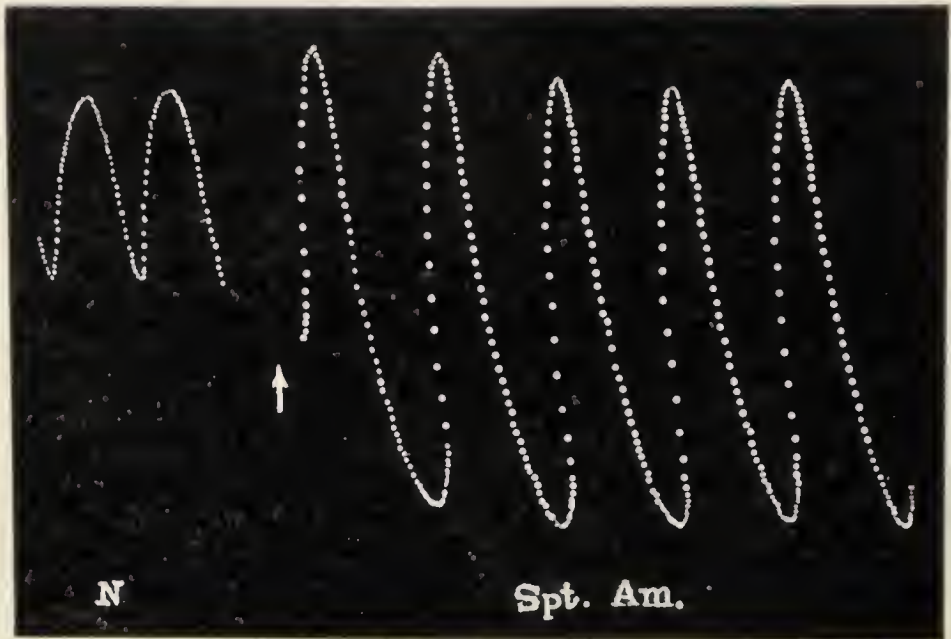

FIG. 169. Stimulating action of Spirit. Ammon. Arom. on Desmodium pulsation.

KBr is a depressant, I applied a dilute solution on the pulsating pulvinule. To my great surprise I found that instead of causing depression it induced enhancement of activity



FIG. 170. Stimulating action of a minute dose kbr on Desmodium pulsation; larger dose KBr causes depression.

as indicated by an increase in the amplitude of pulsation. The depressing action was produced only after continued application or with a stronger dose (fig. 170).

Experiment 177. *Effect of dilute Potassium Bromide on cardiac activity.*—The result described above was so unexpected that I investigated the action of a minute dose of bromide on the heart-beat. On applying it on the sinus,

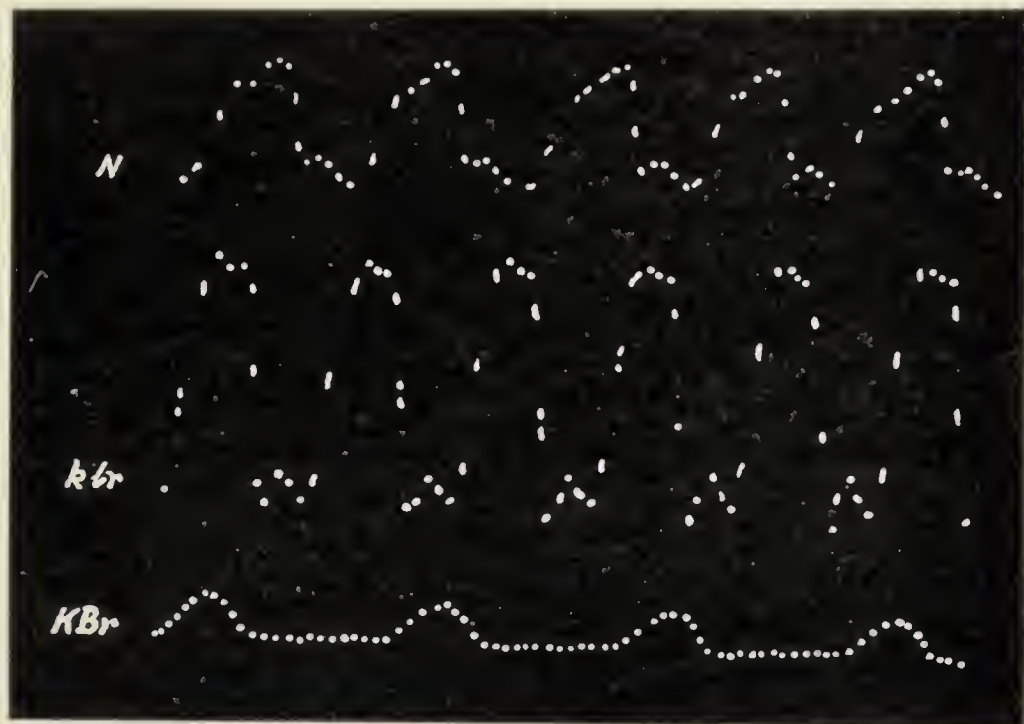

FIG. 171. Opposite effects of minute and strong doses of KBr on heart-beat.

N, normal; kbr, stimulating action of a minute dose;
KBr, depression produced by a large dose (Frog).

the pulsation showed a great increase of amplitude; a stronger dose, however, produced a marked depression (fig. 171). It is very interesting to find that KBr, which is universally regarded as a depressant, causes stimulation in a sufficiently minute dose.

PHYSIOLOGICAL ANTAGONISM OF DRUGS

A most interesting experiment is that on the 'antagonistic action' of drugs. Thus Muscarin and Pilocarpin are known to arrest the heart at diastole. Atropin, however, acts as an antidote, reviving the arrested activity (fig. 172).

Experiment 178. *Antagonistic action of Atropin and Pilocarpin on Desmodium pulsation.*—It is very remarkable



FIG. 172. Antagonistic action of Muscarin and Atropin in arresting and reviving the pulsatory activity of the heart (Frog).

that the two drugs should exert similar antagonistic effects on the pulsation of *Desmodium*. The arrest produced by Pilocarpin was revived by the action of Atropin (fig. 173).

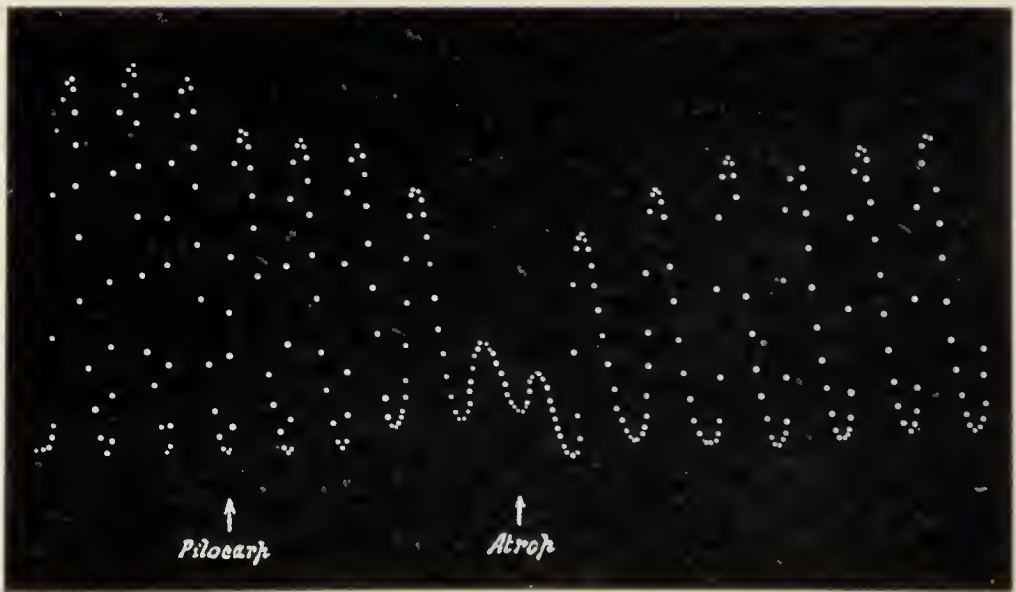

FIG. 173. Antagonistic action of Pilocarpin and Atropin on *Desmodium* pulsation.

The establishment of this identity of reaction in the plant and animal has led to the discovery of the stimulating action of extracts from various Indian plants the physiological properties of which had not hitherto been suspected. An example of this is given on p. 272.

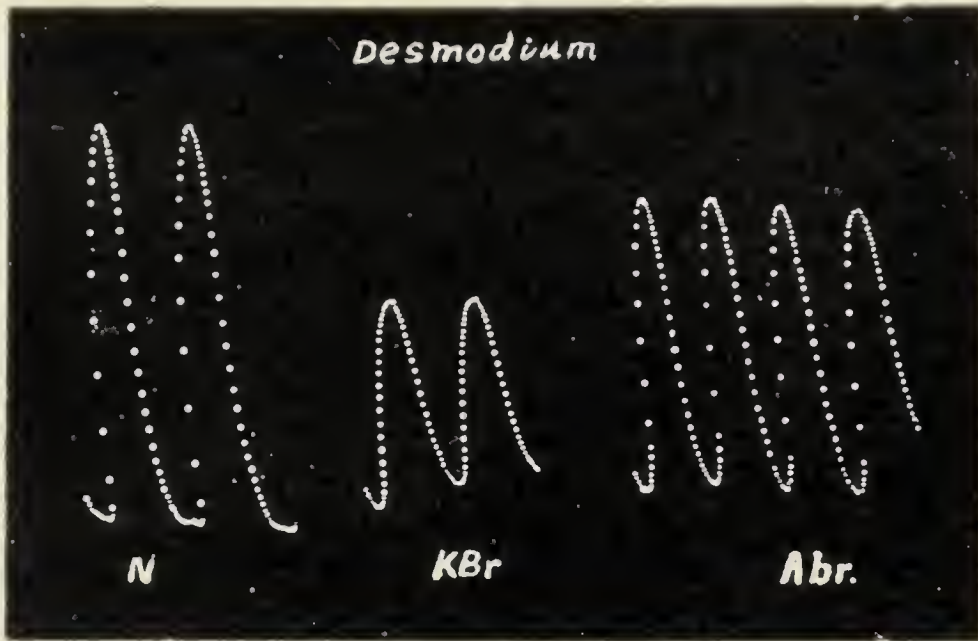

FIG. 174. Revival of depressed activity of *Desmodium* by extract of an Indian plant, *Abroma*.

N, normal ; KBr, depression due to application of KBr solution ;
Abr, revival of activity by extract of *Abroma*.

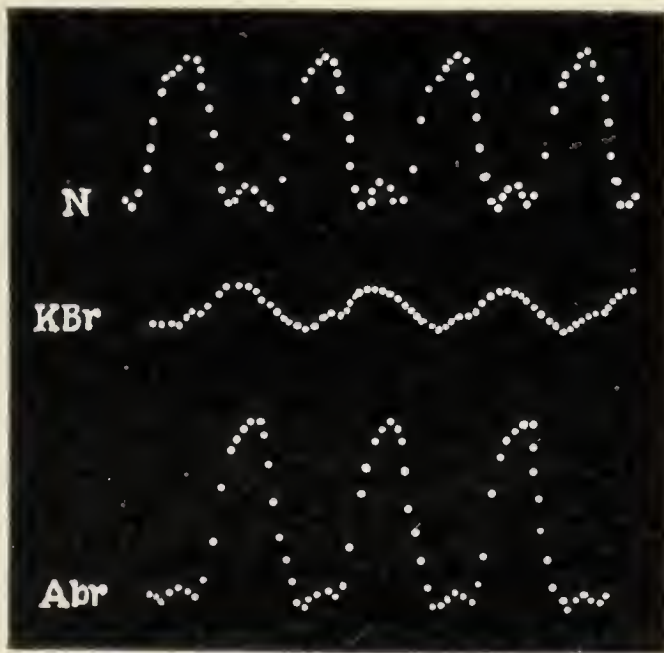

FIG. 175. Parallel effects on pulsating activity of Frog's heart.

N, normal ; KBr, depressed activity under Potassium Bromide ;
Abr, revived activity under *Abroma* extract.

Experiment 179. *Effect of Abroma augusta on Desmodium pulsation.*—The pulsation of *Desmodium* was depressed under the action of KBr; application of extract of *Abroma* removed the depression (fig. 174). This led me to experiment on the action of *Abroma* on the animal heart. The upper record exhibits normal pulsation of the frog's heart; the middle record shows depression induced by KBr; the lowermost exhibits the revival of activity induced by *Abroma* (fig. 175).

SUMMARY

Variations of external conditions induce similar modifications in the pulsating activity of the animal and of the plant.

A diminution of internal tension causes depression or arrest of the heart-beat, the pulsation being revived by suitable increase of intra-cardiac pressure. The pulsation of *Desmodium* is likewise arrested by a diminution of internal hydrostatic pressure, the rhythmic activity being renewed on restoration of the normal pressure.

A supply of oxygen is necessary for maintenance of both cardiac and *Desmodium* pulsation. Carbon dioxide has an asphyxiating action, arresting pulsation.

The pulsation of the heart, as well as that of the *Desmodium* leaflet, undergoes arrest in the condition of subtonicity. In this state of standstill, the pulsatory activity becomes revived on external stimulation.

Stimulation inhibits pulsation in vigorous specimens, while in subtonic specimens it enhances or revives it. Two opposite effects are thus produced which depend on the tonic condition of the tissue.

Variation of temperature induces characteristic modifications of rhythmic activity, which are similar in the animal and in the plant. Arrest occurs below a thermometric minimum, the pulsations becoming revived as soon as the temperature is raised above the critical point. With further

rise of temperature, the frequency of pulsation, within limits, undergoes an increase.

Chemical agents induce reactions which are very similar in the animal and plant.

Stimulating agents like *Spiritus Ammoniae Aromaticus* enhance the rhythmic activity in both animal and plant.

Potassium bromide, which is universally regarded as a depressant, causes enhancement of activity in both animal and plant when in minute dose ; a stronger dose induces the well-known depression in both.

The effect of one drug is often antagonised by that of another. Muscarin and Pilocarpin cause arrest of the heart, whereas Atropin, by its physiological antagonism, revives the activity. Effects exactly parallel are induced in the pulsating leaflet of *Desmodium*.

The characteristic effects of different drugs on plant and animal are so very similar that the physiological action of extracts of various Indian plants on the activity of the animal heart has been discovered by their action on the pulsation of *Desmodium*.

The results of the experiments described above prove that the rhythmic mechanism in plants is essentially similar to that of animals.

CHAPTER XXI

THE PERISTALTIC WAVE

EXPERIMENTS were described in the two previous chapters proving that plants possess an automatic rhythmic mechanism similar to that of animals. Further, continuity between ordinary response and automatic movement was established through the intermediate link of multiple response. Broadly speaking, two types of rhythmic activity were described as occurring in plants, namely :

- (1) *Semi-automatic*, in which rhythmic pulsations occur during external stimulation and for a short time afterwards.
- (2) *Automatic*, in which persistent pulsatory activity is maintained, seemingly without any external stimulation. Prolonged isolation from the action of environmental stimuli, however, brings the pulsation to a state of standstill, to be revived once more on fresh exposure to stimulation.

Various degrees of automatic activity are observed in plants, some being extremely quick and regular, others being less so. Is there also in the rhythmic tissue of the animal a similar gradation of automaticity, and is the difference dependent on the special physiological function that the tissue is called upon to subserve ?

FUNCTIONAL ACTIVITY IN THE PROPULSION OF NUTRIENT
SUBSTANCE

The heart is essentially a tubular organ,¹ each section of which is rhythmic, and in which excitatory contraction proceeds onward from point to point as a peristaltic wave. The rate of propagation of the wave in the animal heart is about 10 to 15 mm. per second, very much slower than the excitatory impulse in nerve. There are, however, certain resemblances in the propagation of the two impulses. In the cardiac tissue, the propagation occurs by sequence of contraction from cell to cell, the passage of excitation being manifested by the *visible* propagation of a contractile wave. The evolutionary process appears to have been carried further in the nervous tissue, the quicker rate of conduction of impulse being secured at the expense of contractility. The nervous impulse is invisible, and its propagation can only be detected by the electromotive change that accompanies it. There are two independent methods of intercommunication between more or less distant organs: the relatively slow propagation of a visible peristaltic wave in cardiac and other tissues, and the rapid transmission of an invisible impulse in the nervous tissue.

PERISTALTIC WAVE IN THE ALIMENTARY CANAL

Is there any other organ in the animal in which similar peristaltic activity for propulsion has been developed, though to a less perfect degree? It is well known that the alimentary canal possesses a peristaltic mechanism, and I will show that it is essentially similar to that of the heart. Since the

¹ 'In the most primitive form, the vertebrate heart is composed of a simple tube, in which a contraction starts at the venous end and is propagated in a wave-like manner along the tube to the arterial end. In the higher vertebrates the heart at its first appearance has the same tubular form, but the simple tube very rapidly becomes modified, partly by twisting on itself, partly by the outgrowth of the dorsal or the ventral wall of the tube to form the cavities of the auricle and ventricles.'—Starling, *Principles of Human Physiology*, 1920, p. 991.

peristalsis of the stomach or of the intestine is not rapid, it is easier to follow it and thus to discover the fundamental laws of peristalsis, as well as the special conditions which determine the unidirectional propulsion of the solid or semi-fluid contents of the organ.

THE PERISTALTOGRAPH

The difficulty encountered in obtaining an accurate record of the automatic pulsation of the stomach is very great. A method often employed is to insert into the gut an air-filled balloon connected with a recording tambour. The introduction of the balloon causes distension and introduces many complications, as noted in the following quotation from Starling: 'Since (pulsations) may apparently arise at any portion of the gut which is subject to any special tension, it is not easy to be certain that a contraction recorded at any point is really propagated from a point two to three inches higher up.'¹

It was therefore necessary to devise a special apparatus for the record (1) of the automatic pulsation of the alimentary canal, and (2) of the peristaltic wave initiated in the organ originally at standstill. The Peristaltograph (fig. 176) consists of a fixed V-shaped rod and a movable vertical lever; the preparation of the stomach is placed between the two and is kept in position by means of two pins. The passage of the peristaltic wave moves the primary lever either inwards or outwards. This slight movement is further magnified by a wheel of small diameter which is made to rotate in one direction or the other by the peristaltic expansion or contraction of the stomach. A long writing-lever attached to the rotating wheel marks successive dots at intervals of 1 or 2 seconds by the electro-magnetic device previously described (*cf.* fig. 7). The compound magnification produced by the primary and the recording-lever is

¹ Starling, *Principles of Human Physiology*, p. 772.

either 100 or 200 times. The first is quite sufficient for general purposes; the second is employed for record of relatively feeble pulsation. The magnification can, however, be readily increased to 500 times, when it is easy to record pulsations which had hitherto remained undetected.

The experiments were carried out with the stomach of the frog and the intestine of the tortoise, mostly in the

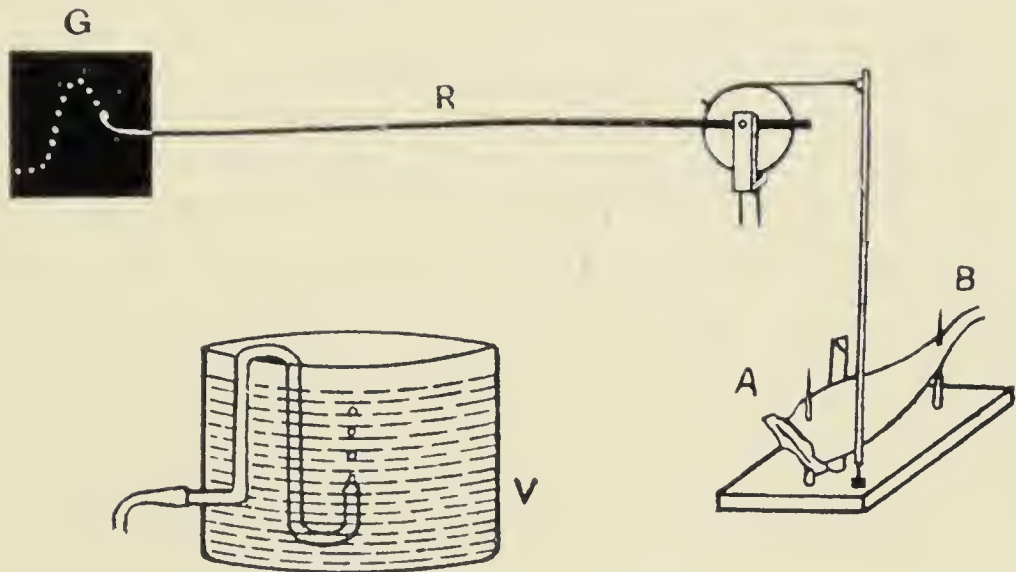

FIG. 176. The Peristaltograph.

Stomach fixed by two pins; A, upper or cardiac end; B, lower or pyloric end. Specimen to be placed in vessel V, filled with Ringer-Tyrodé solution, oxygen being made to bubble through. The vertical primary lever attached to small wheel; R, recording-lever; G, smoked-glass plate.

months of December and January, when many of the frogs were already hibernating and were therefore practically inactive. The non-hibernating specimens with thick stomach-wall were found to be active, exhibiting vigorous pulsations. Several experiments were carried out in early spring (February), the activity of the specimens being then exceptionally great. There was also this difference between the winter- and spring-specimens: the prepared winter-specimens maintained their vitality for more than 24 hours, whereas the spring-specimens, under the prevailing higher

temperature, lost their power of response in less than 12 hours.

The heart exhibits a descending scale of automatic activity from the sinus, where it is highest, to the tip of the ventricle where automaticity is practically absent. Similarly, the automaticity of the alimentary canal is most pronounced in the stomach, whereas it is apparently absent in the intestine, the pulsatory activity of which is induced only under the action of external stimulation. In the stomach itself the excitability is very much greater at the upper or cardiac end than at the lower or pyloric end.

CHARACTERISTICS OF PERISTALTIC PULSATION

The pulsations of the stomach are, generally speaking, extremely irregular. They exhibit all types of variation similar to those of the heart or those of the *Desmodium* leaflet. There are thus periodic groupings, also characteristic notches at systole or diastole. I was, however, successful in obtaining more or less uniform pulsation (1) by removing the contents of the stomach, which caused distension and continuous irritation of the organ, and (2) by reducing the shock-effect of the operation of dissecting out the stomach. This was accomplished by temporarily benumbing the tissue by application of ice.

Experiment 180.—A common type of record is a feeble pulsation followed by a large one, and this in recurrent series (fig. 177); after this, the pulsatory activity tends to become approximately uniform, as seen in fig. 178, in which the quicker up-curve was completed in 8 seconds, whereas the down-curve of recovery occupied the longer period of 30 seconds. There was a subsequent pause which lasted for 25 seconds. In summer-specimens the pulsations are very much quicker. Variation of the rhythmic rate effected by external agents chiefly affects the intervening pause, which becomes shortened or prolonged under induced enhancement or depression of rhythmic activity. Variation of tempera-

ture was found to induce a very marked change in the frequency of pulsation.

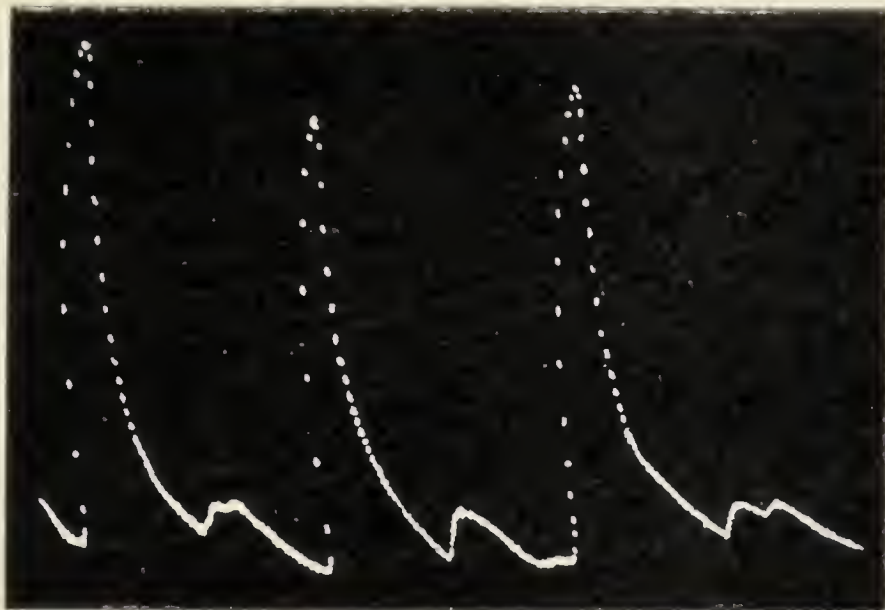

FIG. 177. Record of automatic pulsations of Frog's stomach, alternately of large and small amplitude.

I now demonstrate the identical character of the rhythmic mechanism of the peristaltic action of the cardiac and alimentary tissues by the following series of tests.



FIG. 178. Uniform automatic pulsations of Frog's stomach.

A. Modification of Normal Pulsation :

- (a) by exhaustion of oxygen-supply ;
- (b) by asphyxiating action of CO_2 ;
- (c) by change of temperature.

B. Revival of Pulsation in an Organ when at standstill :

- (a) by electric stimulation, and
 (b) by chemical stimulation.

EFFECT OF EXHAUSTION OF OXYGEN

The oxygen contained in the tissue suffices for the continuation of pulsation for a time in the absence of a fresh supply ; but prolonged deprivation of oxygen causes arrest of pulsation in both animal- and plant-tissues. The asphyxiation produced by CO_2 causes arrest of the heart-beat and

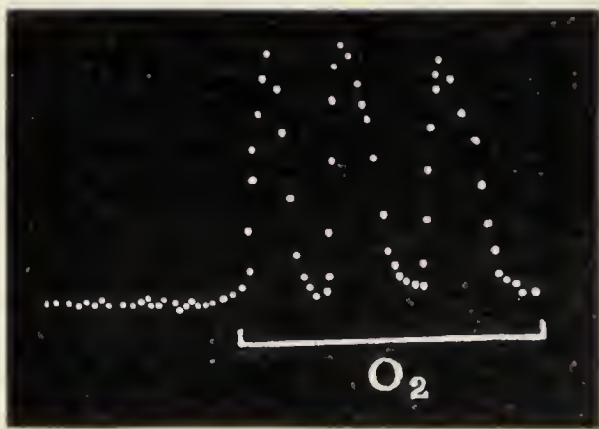

FIG. 179. Arrested pulsation of stomach due to lack of oxygen, revived by application of O_2 (Frog).

of the pulsation of *Desmodium*, the revival being produced by application of oxygen (*cf.* Experiments 161, 162, 163, 164). Similar results were obtained with the animal stomach.

Experiment 181.—The preparation of frog's stomach was kept immersed in normal Ringer-Tyrode solution; the bubbling of oxygen was discontinued and the pulsation became arrested after several hours. That this was due to the lack of oxygen became at once evident by the revival of pulsation on addition of oxygenated water to the solution (fig. 179).

ASPHYXIATION BY CO₂

Experiment 182.—On allowing CO₂ to bubble through the solution in which the frog's stomach was immersed, the pulsation became arrested. Gradual application of CO₂

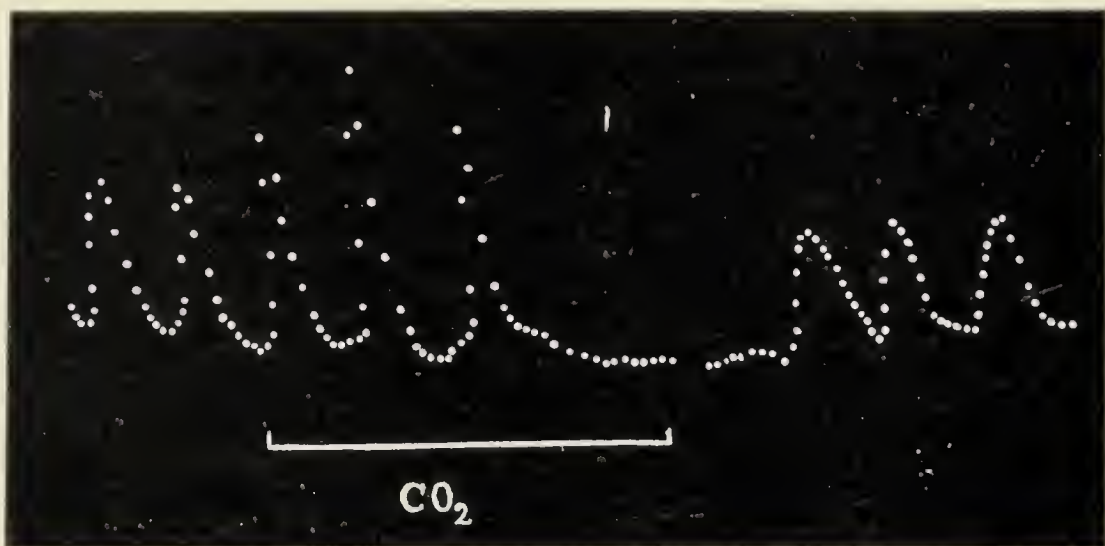

FIG. 180. Effect of CO₂ on normal pulsation of Frog's stomach. Note preliminary enhancement followed by arrest. Pulsation revived by application of O₂.

produced a preliminary enhancement followed by depression and arrest under continued application. The arrested pulsation under CO₂ can, however, be revived by immediate substitution of oxygen for carbonic acid gas (fig. 180).

EFFECT OF VARIATION OF TEMPERATURE ON PULSATION

The rhythmic activity of both the *Desmodium* leaflet and the animal heart becomes slowed down and arrested at a thermometric minimum. Rise of temperature, on the other hand, enhances the frequency of pulsation. The results are to some extent modified by the temperature to which the organisms had been accustomed (*cf.* Experiment 171).

Experiment 183.—Very similar effects are observed in the pulsation of the stomach of the frog. Thus, in a particular specimen the arrest at thermometric minimum

occurred at 10° C., the pulsation being revived by a rise of temperature above this critical point. The frequency underwent continuous increase with rise of temperature; the amplitude of pulsation at 37° became so reduced that the

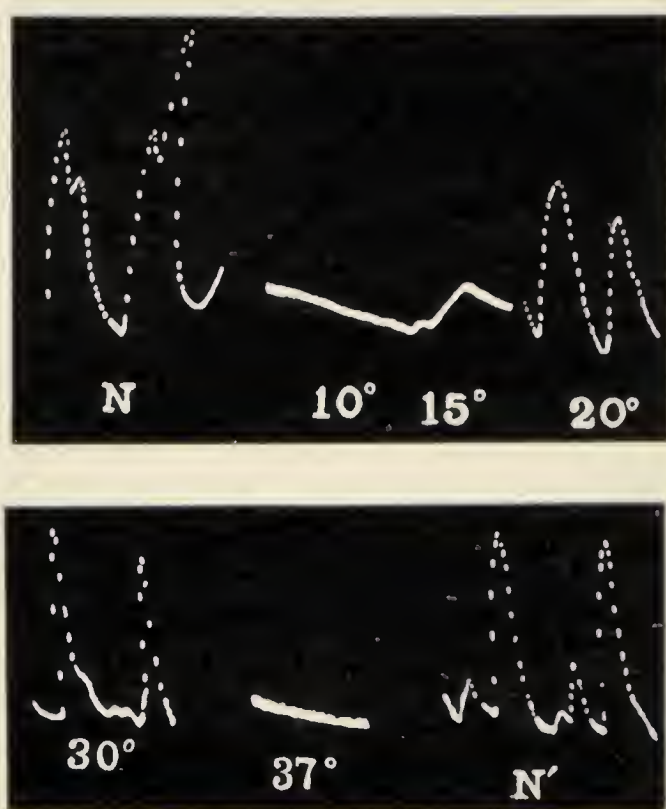

FIG. 181. Effect of variation of temperature on pulsation of Frog's stomach.

Pulsation came to a stop at thermometric minimum of 10° C. Rise of temperature enhanced the frequency. At 37° there was an apparent arrest; pulsation, however, revived on return to normal room-temperature N' .

pulsatory activity appeared to have been abolished. That this was not the case became clear on allowing the temperature to fall to that of the room, when the pulsations became almost as vigorous as at the beginning (fig. 181).

EFFECT OF STIMULATION OF ORGANS AT STANDSTILL

Both the leaflets of *Desmodium* and the frog's heart are brought to a state of standstill by the condition of subtonicity. A feeble stimulation then causes a single response,

while a stronger stimulation gives rise to a series of multiple responses. The persistence of the revived pulsation depends, moreover, on the amount of stimulation (*cf.* Experiments 146, 147, 148).

Precisely similar effects are observed in the response of the stomach. The tonic condition of the isolated stomach was found to undergo decline till the pulsation came to a state of standstill. The following experiments describe the effect of external stimulation in reviving the rhythmic activity.

EFFECT OF FEEBLE AND OF STRONG ELECTRIC STIMULATION ON STOMACH AT STANDSTILL

Experiment 184. *Effect of feeble stimulation.*—The quiescent stomach was stimulated directly ; a single feeble

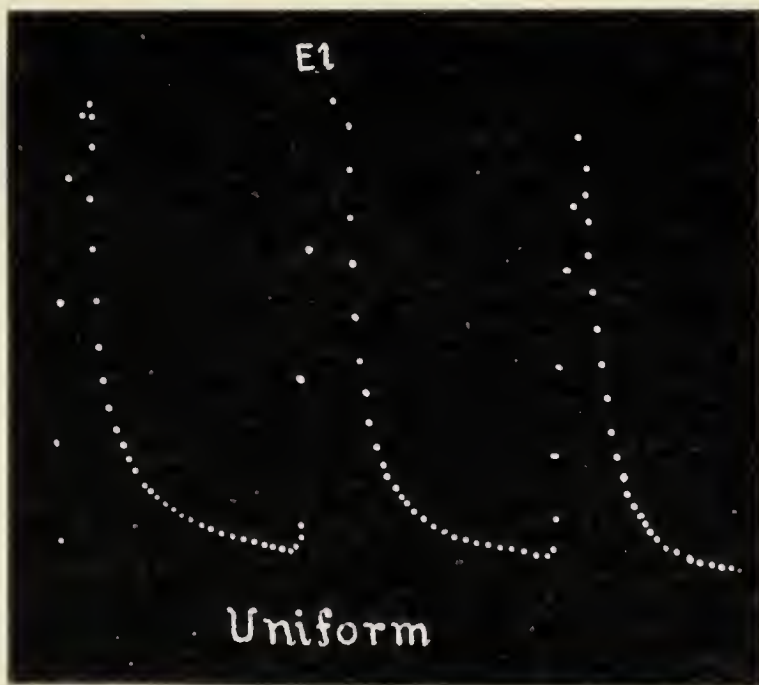

FIG. 182. Uniform responses of quiescent stomach under successive feeble electric stimulations (Frog).

electric shock was found to give rise to a single response ; the uniformity of the successive responses thus induced is shown in fig. 182.

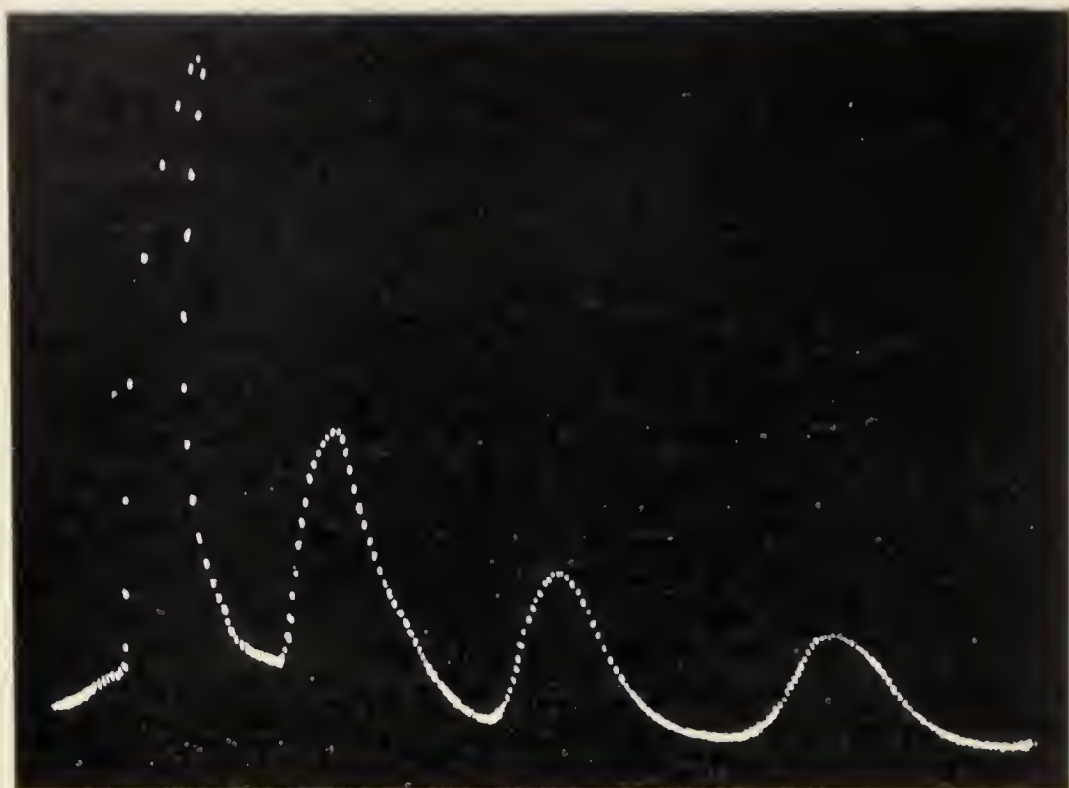

FIG. 183. Four recurrent responses under moderate stimulation.

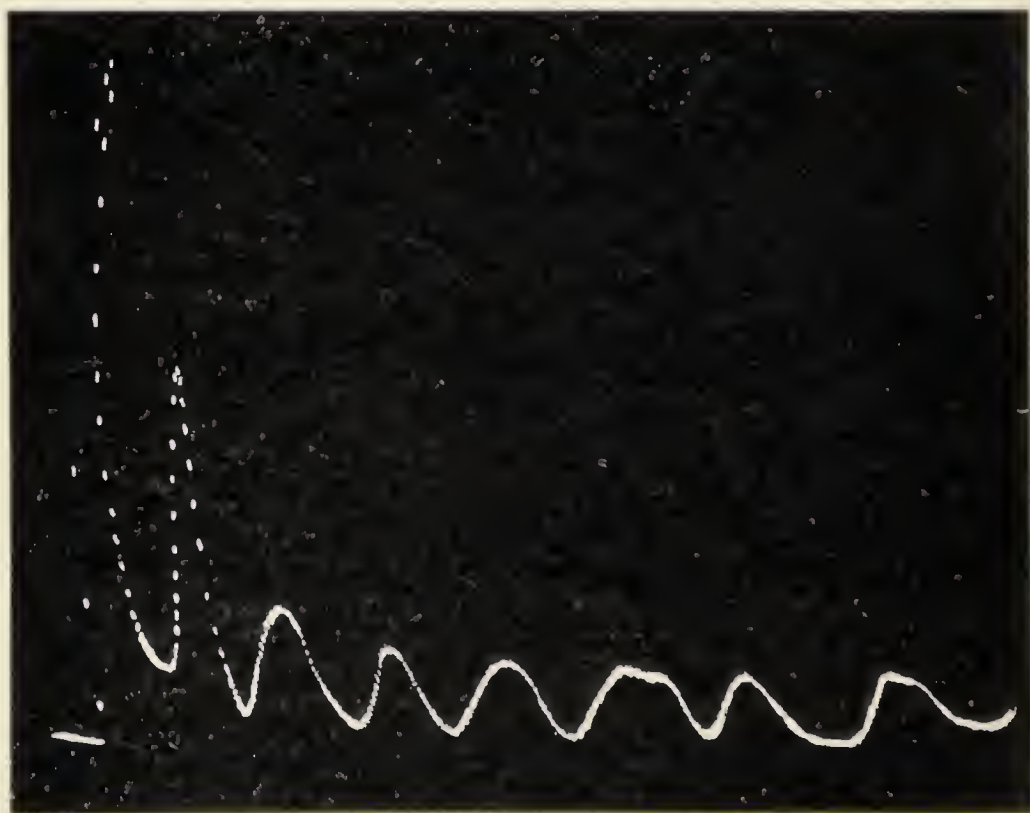

FIG. 184. Stimulus of intensity 2 applied for 2 seconds gave rise to 8 recurrent pulsations (the movement of the recording plate was slowed down to half) (Frog).

Experiment 185. *Effect of moderate stimulation.*—Electric stimulation of moderate intensity (1 unit) was applied for 1 second; a series of 4 recurrent responses was now obtained in the place of a single response under feeble stimulation. Note the gradual decrease of amplitude and the prolongation of period of the successive pulsations (fig. 183).

Experiment 186. *Effect of prolonged and stronger stimulation.*—The duration of application of stimulus was prolonged to 2 seconds and the intensity increased to 2 units. The result was 8 recurrent pulsations recorded on a slower moving smoked plate (fig. 184).

The persistence of pulsatory activity thus depends on the amount of stimulation.

EFFECT OF CHEMICAL STIMULATION

Experiment 187.—Chemical stimulation also revives the activity of the tissue previously in a state of standstill. I give a record (fig. 185) which shows the revival of activity

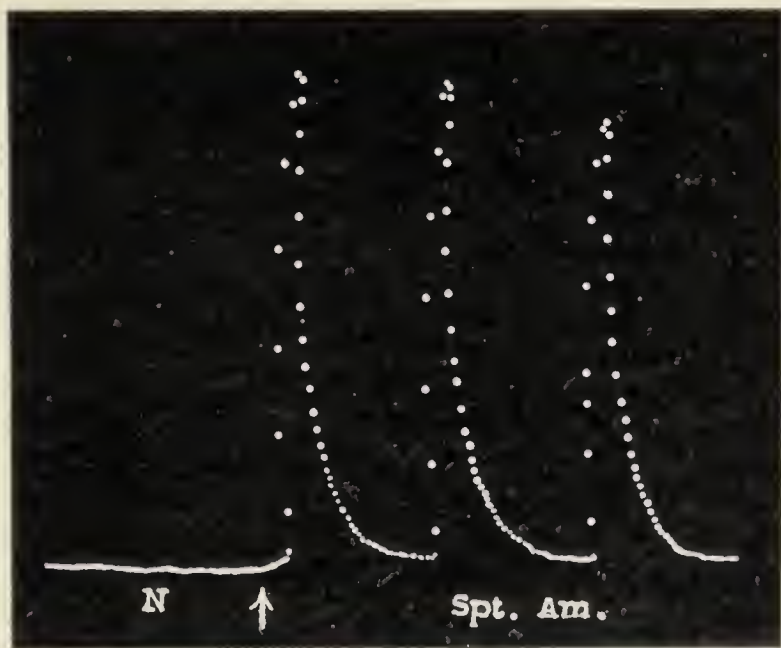

FIG. 185. Stimulating action of Spt. Ammon. Aromat. in reviving arrested activity N.

in a quiescent stomach by the application of Spiritus Ammoniae Aromaticus.

Fresh bile from an animal was also found to be a very effective stimulant in reviving or enhancing the activity of the stomach.

PERISTALSIS AND ANTIPERISTALSIS

Contractions causing movement onwards are generally known as *peristalsis*, and those in the opposite direction, *antiperistalsis*.¹ The wave propagated in the normal direction from the upper (cardiac) end of the stomach A to the lower (pyloric) end B is designated as the peristaltic. Under certain circumstances the wave may become antiperistaltic, the direction of propagation being reversed from B to A. What are the laws which determine the direction of propagation? Experiments carried out with the stomach of the frog throw much light on the subject.

PERISTALTIC WAVE IN THE HEART

Normal peristalsis.—It is of much interest in this connexion to consider the phenomenon of peristalsis in the heart. The activity of its constituent parts is found to be very different, that of the sinus being very great, while that of the ventricle is exceptionally feeble. The sequence of normal pulsation is sinus, auricle and ventricle, the direction of propagation being determined by the differential activity at the two ends of the organ. In other words, *the propagated impulse follows the activity-gradient from the more active to the less active region*.

Reversed peristalsis (antiperistalsis).—The natural differential activity may, however, be reversed by artificial means; for example, by local stimulation of the relatively inactive ventricle. Thus it is possible to raise the activity

¹ Bayliss, *Principles of General Physiology*, p. 368.

of the ventricle to a higher pitch than that of the sinus, with the result that the direction of propagation is now reversed, the sequence being ventricle, auricle and sinus. Even in this case the propagated impulse follows the activity-gradient *from the activated to the less active end*.

The differential activity at the two ends of the organ which determines the direction of peristalsis thus depends (1) on natural differential activity at the two ends of the organ, and (2) on differential activity artificially induced by activation of one end of the organ by local stimulation.

PERISTALTIC WAVE IN THE STOMACH

The normal peristaltic and the reversed antiperistaltic waves can be clearly demonstrated in the quiescent stomach by the application of stimulus alternately at the upper cardiac end A and at the lower pyloric end B. The recording point of the Peristaltograph is half-way between the two ends.

When stimulus is applied at the upper end A, the excitatory peristaltic wave generated by it, travels in the normal direction and reaches the recording point. Stimulation of B gives rise, on the other hand, to a reversed antiperistaltic wave which also reaches the recording point. The intensities of the transmitted peristaltic and antiperistaltic waves are shown by the amplitude of the responses in the two cases.

EFFECT OF STIMULATION OF MODERATE INTENSITY

Experiment 188. *Mechanical stimulation*.—A pinch was applied first at the upper end A; the transmitted effect of this in the normal direction gave rise to a single response of large amplitude. The antiperistaltic wave caused by pinching B also gave rise to a single response, the amplitude

of which was about four times smaller. *The transmitted effect in the normal and usual direction is thus considerably greater than that in the reversed direction* (fig. 186). I obtained similar results with thermal stimulation.

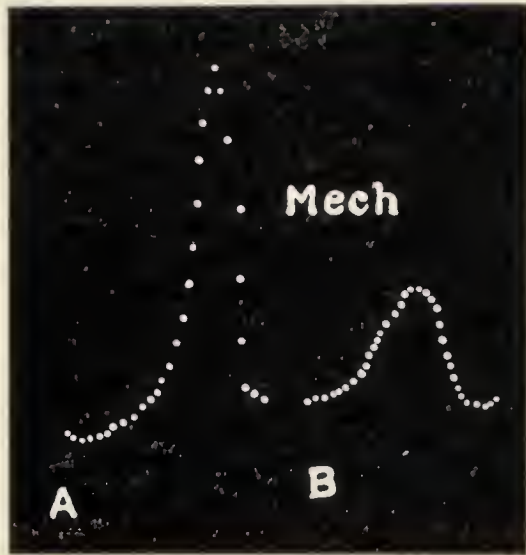

FIG. 186. Responses to mechanical stimulation applied at upper end A, and lower end B (Frog)

Experiment 189. *Effect of electric stimulation.*—This mode of stimulation has the special advantage of securing uniformity of stimulation at the two ends. The time of



FIG. 187. Responses to electric stimulation successively applied at A, at B, and once more at A (Frog).

transmission in the two directions can also be determined with greater accuracy.

The course of experimental procedure was as follows: the recording point was exactly half-way between A and B, so that the distance of transmission was the same in the normal and in the reversed direction. The record of the transmitted peristaltic excitation due to stimulation of A was first taken, then the record of the antiperistaltic transmission of the effect of stimulation of B. Finally, to make allowance for any possible change of excitability, a third record was taken of the effect of stimulation of A. The result shows that the excitability had undergone no change during the period of the experiment.

The intensity of the peristaltic transmission was found to be about four times greater than that of the antiperistaltic transmission (fig. 187). The time of transmission of the former was only 2.5 seconds, whereas that of the latter was 11 seconds or about four times longer.

EFFECT OF CONTINUOUS STIMULATION, MECHANICAL, CHEMICAL, OR THERMAL

Experiment 190. *Effect of distension.*—Internal distension has been shown to induce revival of pulsation in both the *Desmodium* leaflet and the heart. Distension of the stomach was produced alternately at the A and B ends by the forcible introduction of a plug of cotton-wool, which acted as a constant mechanical stimulus. The effect is shown in fig. 188. The feeble pulsation at the beginning became greatly enhanced by the mechanical distension at A. Withdrawal of the plug was followed by enfeeblement of pulsation. The plug was next introduced at the end B, with the result of enhanced pulsatory activity which was less intense than that induced by the stimulation of the upper end A.

I next describe the effects of continuous application of chemical and thermal stimulation. In order to avoid useless

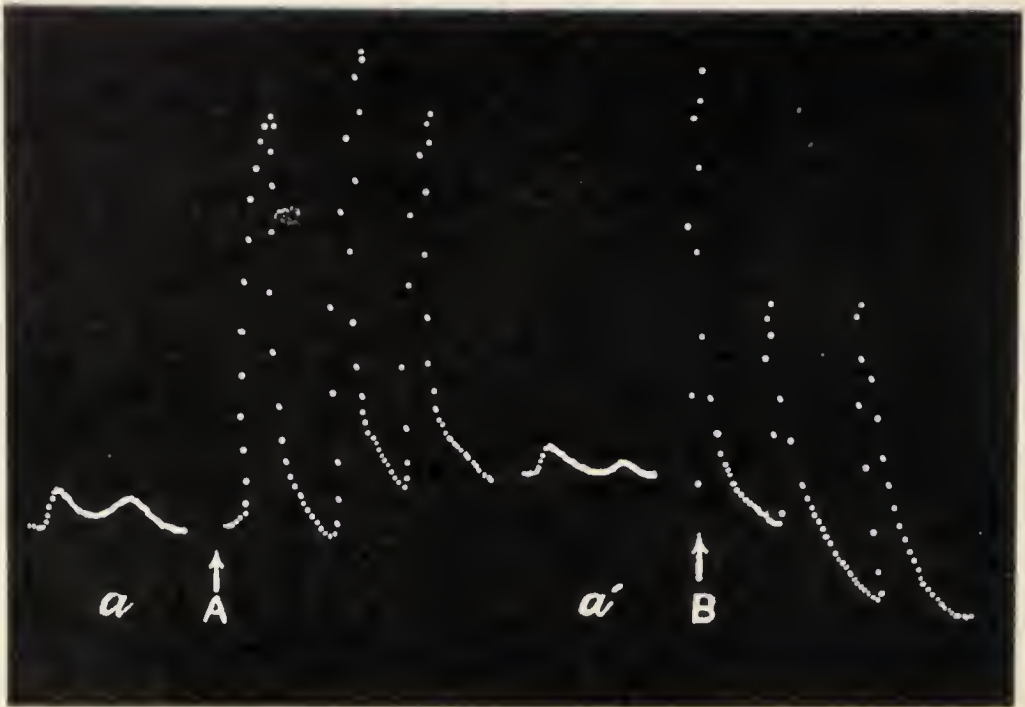

FIG. 188. Effects of successive distension of A and B ends.

a, feeble existing pulsation ; persistent enhancement of pulsation by mechanical distension of A end by introduction of a plug ; *a'*, return of feeble pulsation after withdrawal of plug. Introduction of plug at B end gives rise to persistent pulsation less intense than that caused by distension of A end.

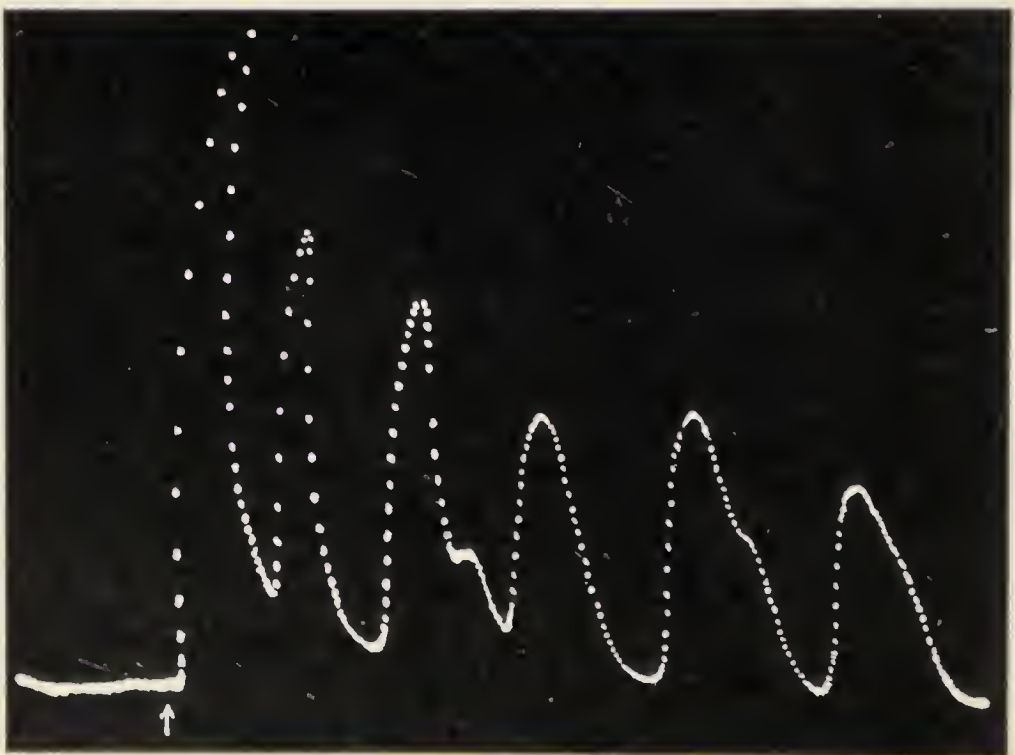

FIG. 189. Effect of continuous chemical stimulation with Cholin Chlorate (Stomach of Frog).

repetition I will describe only the effect of application at the upper end A.

Experiment 191. *Effect of continuous chemical stimulation.*—Bile extract is known to be a strong stimulant of the intestine. I applied solution of Cholin chlorate to the upper



FIG. 190. Effect of unilateral thermal stimulation applied at H in reviving the peristaltic activity of the stomach.

end of a quiescent stomach ; this gave rise to vigorous and persistent pulsations (fig. 189).

Experiment 192. *Effect of thermal stimulation.*—The specimen had become subtonic and was in a state of standstill. A stream of warm water was now applied at the upper end A. This caused a revival of peristaltic activity (fig. 190).

SUMMARY

The animal stomach exhibits rhythmic activity similar to that of the heart and to that of the pulsating leaflet of *Desmodium*.

The pulsating activity of the stomach is dependent on a supply of oxygen ; it becomes arrested by the asphyxiating action of CO_2 .

The frequency of pulsation is modified by variation of temperature ; it is slowed down and becomes arrested at a thermometric minimum. Rise of temperature, within limits, increases the frequency of pulsation.

In the condition of subtonicity, the pulsation of the stomach comes to a standstill. In this state, a feeble stimulation causes a single response. Stronger stimulation, on the other hand, gives rise to a series of multiple responses. The persistence of the pulsatory activity induced depends on the amount of stimulation. A peristaltic wave may be initiated in a quiescent stomach by activating one or the other end of the organ by local stimulation. The excitation transmitted in the normal peristaltic direction is more intense than that transmitted in the reverse or antiperistaltic direction.

The different modes of stimulation employed to activate the organ are: (1) mechanical distension; (2) electric stimulation; (3) chemical stimulation; and (4) thermal stimulation.

The results described show that the direction of propagation is determined by the differential activity at the two ends of the organ.

The Law of Propagation of the Peristaltic Wave may be expressed in two different ways:

(1) THE DIRECTION OF PROPAGATION OF THE PERISTALTIC WAVE IS FROM THE MORE ACTIVE TO THE LESS ACTIVE POINT.

(2) THE PERISTALTIC WAVE FOLLOWS THE STIMULATION-GRADIENT FROM THE STIMULATED TO THE UNSTIMULATED REGION.

CHAPTER XXII

THE PROPULSION OF THE SAP

THE identical character of the rhythmic mechanism in the plant and animal has been demonstrated in the foregoing chapters. The peristaltic action by which the contents of the heart and of the stomach are propelled forward has been discussed. The law determining the direction of propagation of the peristaltic wave has also been established.

Turning now to the propulsion of sap in plants, the hypothesis of physiological action received a severe blow from the inconclusive experiments of Strasburger on the action of poison. He found that when the cut end of a tree-trunk was kept in a bath of poison, the ascent of sap still persisted, the leaves exhibiting no sign of drooping for many days. The inference drawn from the experiment was that living elements could not in any way co-operate in the ascent of sap, since application of poison must necessarily kill all living tissues. My investigations, to be presently described (Experiment 193), lead to a conclusion diametrically opposite to Strasburger's, proving that the movement of sap is brought about by the activity of living cells. It should be stated that Strasburger himself was fully aware of the inadequacy of a purely physical theory.¹

¹ 'The character of the forces which cause the ascent of the transpiration current is still unexplained; whilst transpiration makes a place for the inflowing water, it does not furnish the force which is necessary to rapidly convey a large volume of water for a considerable distance through the wood. Every operation by which work is accomplished implies a corresponding expenditure of force; and the force capable of raising great masses of water to the tops of a tall Poplar, or of a Eucalyptus, 150 m. high, must be considerable. But, as yet all efforts to determine the nature of this force have been fruitless. Osmotic forces act too slowly to be of any value, and, moreover, there is no fixed distribution of osmotic substances that would account for such a current.'—Strasburger, *Text-book of Botany* (English translation), p. 187.

Since the activity of living cells is precluded according to the erroneous inference drawn from Strasburger's results, it has been supposed that the ascent of the sap is mainly due to the activity of the terminal organs, of which the root exerts an upward pressure from below and the transpiring leaves a suction from above. There is no specific activity in the stem itself for effecting propulsion.

The removal of water from the leaves by transpiration is supposed to exert a pull along cohering columns of water in the vessels present in the wood. But since the water-columns in the vessels are not continuous, being interrupted by air-bubbles, it is obviously impossible for these strands of water to withstand tension, particularly if they are interrupted here and there. So much for the pull from above. A push from below is supposed to be exerted by root-pressure. But in the Palm there is no detectable root-pressure, yet the sap rises to a height of more than a hundred feet. Again, when the need of the tree is greatest during active transpiration, the root-pressure, instead of being positive, is actually negative. The fact that the presence of the terminal organs is by no means essential for the process will be demonstrated later by evidence that the sap-movement persists even after complete removal of the root and the leaves.

The principal difficulty in the investigation of the propulsion of sap has been the absence of any adequate method for its detection. This has been removed by a number of independent devices and instruments of very great sensitiveness. The methods are as follows :

- (1) The Method of Erectile Response of the Leaf.
- (2) The Method of the Sphygmograph.
- (3) The Method of Electric Record.
- (4) The Method of the Potograph.

The details of each of these methods will be given later. The important point to be noted is that though the methods of experimentation are so widely different, yet they all bear

concurrent testimony to the correctness of the results that have been secured.

The results of numerous experiments performed on these methods led to the conclusion that the propulsion of sap in the plant is effected by a living rhythmic mechanism. The important results are as follows :

- (1) The rate of flow of sap is shown to be correspondingly modified by all conditions which enhance or depress other pulsatory activities of animals or plants.
- (2) The existence of an actively pulsating propulsive tissue is demonstrated by the concomitant electric pulsations ; the active layer is localised by means of the Electric Probe.
- (3) The passage of a peristaltic wave in the propulsion of sap is exhibited in the sphygmographic record of pressure-variation, analogous to that of the variation of blood-pressure in the artery of an animal.
- (4) In the animal the peristaltic wave in the propulsion of blood can be reversed. Similar reversal is demonstrable in the case of the plant.

PHYSICAL VERSUS PHYSIOLOGICAL THEORY

In regard to the action of poison, Strasburger was led to believe (1) that the leaves of the poisoned tree did not show any sign of drooping, and (2) that the rate of ascent was not affected by the poisoning. The following experiments demonstrate, however, that the leaves do exhibit drooping and that the ascent of sap does become abolished under the action of poison.

Effect of poison on the attitude of the leaf.—The physiological activity underlying the ascent is strikingly demonstrated by the contrasted effects of a stimulant and a poison on the leaf. There are various herbaceous plants in which the rate of ascent is exceptionally high. When water is withheld from such a plant, the stem doubles over : the

leaves become dry, crumpled up, and to all appearance, dead. When water is applied to the freshly cut end of the drooping stem, a remarkable change takes place. The original turgor is restored: the bent stem straightens up and the withered leaves spread out in their original vigour. In an Indian plant, *Swertia Chirata*, the transformation from apparent



FIG. 191. Left: Erect shoot placed in poisonous solution p, and drooping shoot in stimulating solution s. Right: The poisoned shoot droops and dies, while the drooping shoot becomes erected.

death to a fully erect and outspread attitude is attained in a period as short as 4 minutes. An even quicker revival takes place if the water contains traces of a stimulant. The effect of a poisonous solution on an erect and vigorous specimen is precisely the opposite; the leaves, from below upwards, collapse in succession; the stem also undergoes collapse, and the plant soon becomes a huddled mass of dying tissue.

Experiment 193.—An erect shoot of *Centaurea* was placed in a vessel P containing a poisonous solution of Potassium Cyanide, while a drooping specimen of the plant was placed in a vessel S which contained a stimulant (the photograph on the left, fig. 191). The opposite effects of poisonous and of stimulating solutions are strikingly shown in the photograph on the right, taken after 20 minutes. The erect specimen in the poison shows complete collapse, while the drooping shoot in the stimulant exhibits a vigorous recovery (fig. 191).

I will next show that under the action of poison the rate of movement of sap undergoes a diminution which culminates in permanent arrest.

SIMULTANEOUS ACTION OF POISON ON SUCTION AND ON LEAF-MOVEMENT

Experiment 194.—The cut end of a shoot of *Helianthus annuus* was placed in a poisonous solution of arsenic. Observation was taken every 5 minutes of the changing rate of suction by the Potograph fully described in a subsequent chapter (*see* fig. 216). The responsive movement of the leaf was also taken simultaneously.

The normal rate of suction associated with the ascent of sap was 3.6 cubic mm. per minute. This fell to 2.4 cubic mm. 5 minutes after the application of the poison. The subsequent diminution of the rate was very rapid, suction being abolished after 45 minutes.

The diminishing rate of ascent of sap is shown independently by the responsive fall of the leaf, which was determined by the following simple method. A glass fibre was attached to a leaf to serve as an index, the responsive movement being measured against a circular scale. The leaf, borne on the stem with its cut end in water, was in the normal outspread position about 20° above the horizon or at an angle of $90^\circ + 20^\circ = 110^\circ$ measured from the vertical stem below. Substitution of poison for the

water produced an almost immediate movement of fall, which increased continuously with the duration of application. The total angular fall in 45 minutes was 85° . The fall, which occurred immediately, was not due to the action of poison on the leaf itself, for it takes a considerable length of time for the poison to ascend through the intervening distance. The fall of the leaf indicated an insufficient supply of water, which is clearly attributable to a diminution in the rate of ascent of sap in the stem caused by the action of poison. The poison reached the leaf later, and killed it. The following table gives the successive rates of suction every 5 minutes, and the increasing angular fall of the leaf.

TABLE XVII.—DIMINISHING RATES OF SUCTION AND THE ANGULAR FALL OF THE LEAF UNDER POISON (*Helianthus annuus*).

Interval after application of poison	Rate of suction in cubic mm. per minute	Angular position of the leaf in degrees
Zero	3·6	110·0
5 minutes after	3·2	107·0
10 " "	2·4	99·0
15 " "	1·6	83·3
20 " "	0·93	69·2
25 " "	0·53	55·0
30 " "	0·33	45·2
35 " "	0·16	35·8
40 " "	0·04	28·9
45 " "	0·00	24·8

The curves given in fig. 192 show that the effect of poison was a simultaneous diminution of the rate of suction and an increasing fall of the leaf. The movement of sap takes place in even small pieces of cut stem; the activity underlying the propulsion of sap is therefore not confined to any particular region of the plant, but exists throughout its length. In the experiment described, the diminishing rate of ascent and its final abolition indicated that the rise of poison put successive active zones of the living stem out of action.

The experiments that have just been described con-

clusively prove that the ascent of sap is essentially due to the activity of living cells. The question whether this activity is of a rhythmic character can be settled by some of the tests previously employed in the determination of the pulsatory character of a tissue. It has been shown that stimulation causes an enhancement of the activity of the

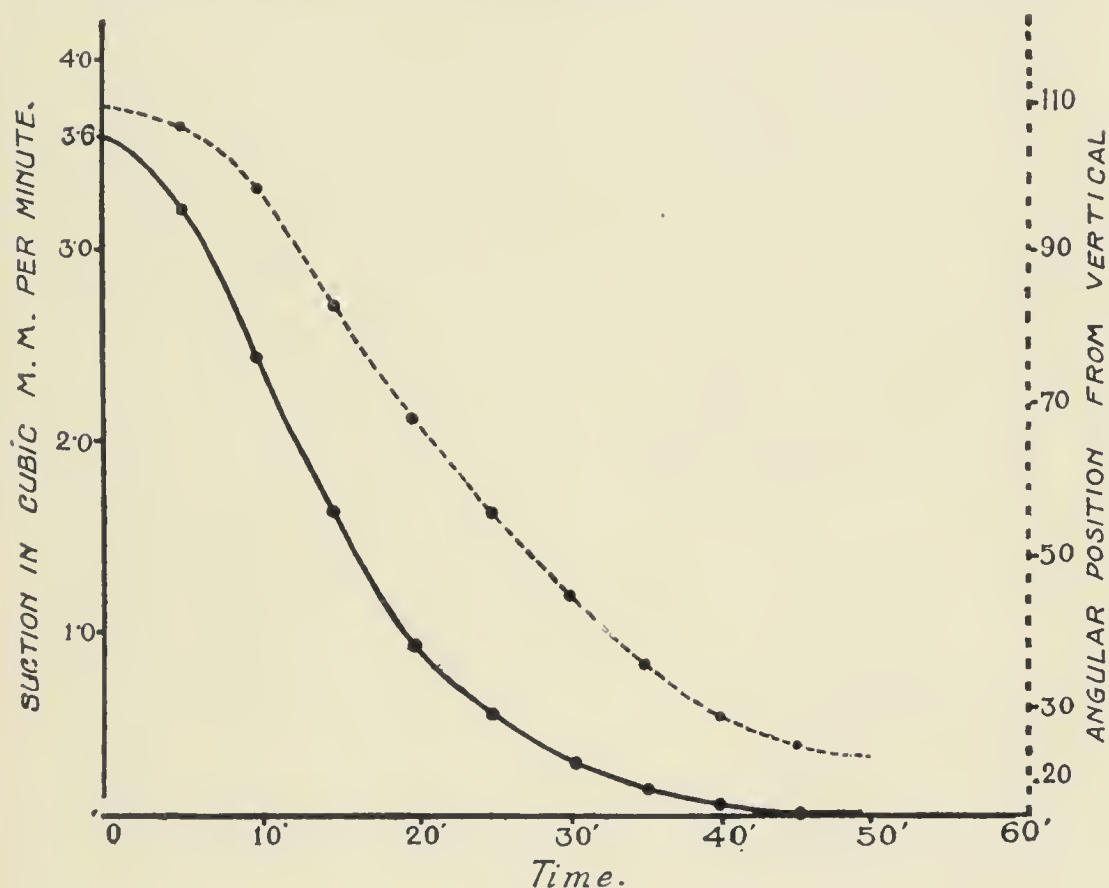

FIG. 192. Effect of poisonous solution in diminishing the rate of suction (continuous curve): the responsive fall of the leaf (dotted curve).

heart when in a subtonic condition; a similar reaction was observed in the case of the pulsating leaflet of *Desmodium*. Their rhythmic activity was enhanced by a rise and depressed by a fall of temperature, and underwent characteristic modifications under the action of stimulating and depressing drugs. In carrying out the various tests in this chapter the leaf served as the indicator of the movement of sap. The accompanying records are curves traced by a leaf of the shoot under experiment.

THE METHOD OF ERECTILE RESPONSE

The principle of this method depends on utilising the leaf as an indicator of the movement of sap. When the activity of the propulsion of sap undergoes a diminution, the leaf exhibits a movement of fall; enhanced activity,

on the other hand, causes a rapid erection. These movements are, however, too slight in themselves for direct observation; they are rendered conspicuous under high magnification, as in the Phytograph already described (*see* fig. 7).

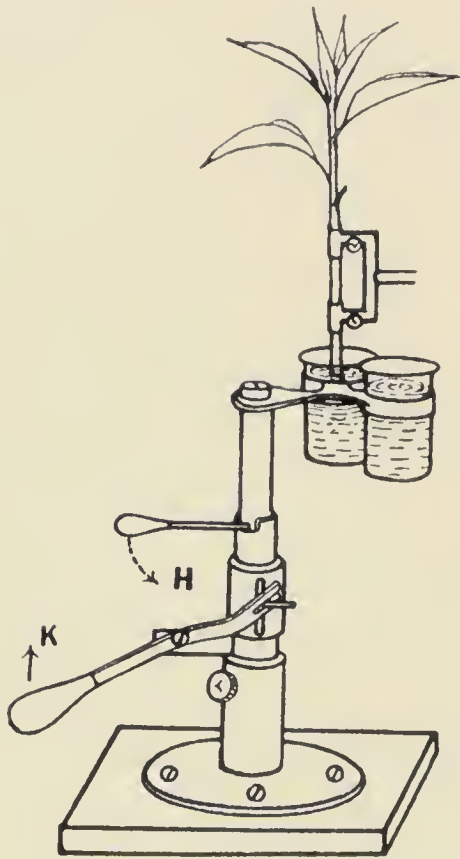

FIG. 193. The Applicator for applying different solutions at cut end of the stem.

The response obtained with the leaf of a cut shoot is practically the same as that of an intact plant with roots; a cut shoot obviously offers greater facilities for manipulation. The cut end of the shoot can be acted upon in rapid succession by cold or warm water or by chemical depressants or stimulants. The Applicator has been devised for this purpose: it consists of a nose-piece carrying two small test-tubes containing

different solutions, which can be raised or lowered by means of the key K, while the handle H brings one or the other test-tube under the cut end of the stem (fig. 193).

For securing good results, it is necessary to choose young and vigorous specimens. It may be said in general that the power of response is dependent on the physiological activity of the specimen, which is modified by age, season, and climatic conditions. Old specimens exhibit feeble

activity; the excitability of the plant is greatly depressed during stormy weather, but on succeeding sunny days the excitability is found to be above the normal. It is probable that this is due to the favourable after-effect of mechanical stimulation caused by the swaying movements of the plant during storm. Temperature has a very marked influence on the activity of the ascent. The temperature at midday in summer in the plains is often as high as 38° C., which is above the optimum of the plant. Satisfactory records can therefore be obtained only in the morning, when the temperature is near 32° C. In my Mayapuri Research Station in the hills at Darjiling, at a height of 7000 ft., the temperature in the morning inside the greenhouse was as low as 13° , and good results were obtainable only at midday when the temperature had risen to 25° C.

The following is a list of plants arranged according to their activity in the transport of sap :

- (1) *Swertia Chirata*.
- (2) Lupin.
- (3) Snapdragon (*Antirrhinum*).
- (4) Cornflower (*Centaurea*).
- (5) *Chrysanthemum coronarium*.
- (6) Cosmos.
- (7) Tomato.
- (8) Phlox.
- (9) Impatiens.

Though Impatiens is not very active, I have used it for a large number of my experiments, since it is easily available in all parts of the world, and practically through all seasons of the year.

EFFECT OF STIMULATION IN REVIVING PROPULSIVE ACTIVITY IN SUBTONIC SHOOTS

Experiment 195. *Effect of photic stimulation*.—In order to induce the condition of subtonicity, the specimen was kept in the dark for 24 hours within a glass covered with black

cloth. The feeble rate of ascent of sap in the depressed condition of the plant was indicated by a slow erectile response of the indicating leaf after irrigation. The removal of the black cloth, exposing the plant to the stimulus of strong diffuse light of the sky, caused increased activity, as shown



FIG. 194.

FIG. 194. Effect of stimulus of light applied at L in enhancing the activity of ascent.



FIG. 195.

FIG. 195. The arrested activity of ascent revived by electric stimulation at E.

in the very erect curve of response (fig. 194). It might be thought that the enhanced rate of ascent was not due to stimulation as such, but to the indirect effect of light in opening the stomata of the leaves and causing greater transpiration. But the greater loss of water by transpiration would have produced, not the erectile movement which actually took place, but the fall of the leaf.

Experiment 196. *Effect of electric stimulation.*—In order

to eliminate the complications possible in the case of light, I next employed stimulation by tetanising induction-shocks. To begin with, the specimen was so subtonic that there was no active ascent, the record given by the leaf being horizontal. On subjecting the length of the stem to electric stimulation, the activity of ascent was revived, as shown by the up-curve traced by the leaf (fig. 195).

EFFECT OF VARIATION OF TEMPERATURE

Experiment 197.—The plant was in a condition of incipient drought and the first part of the record indicates a

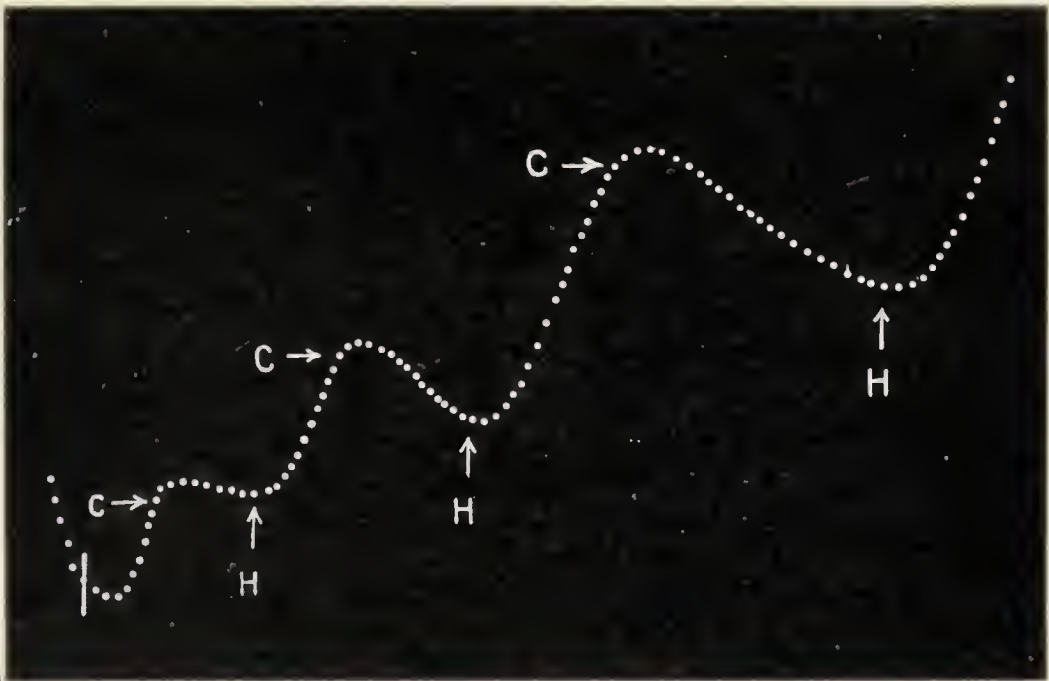

FIG. 196. Effect of alternate application of cold *c* in depressing (down-curve) and of heat *h* in enhancing (up-curve) rate of ascent of sap, as traced by the indicating leaf.

fall of the leaf. Water at ordinary temperature was applied at the vertical line. This caused, after a short latent period, an erectile movement of the leaf. Cold water was next substituted at *C*; this resulted in an arrest of the erectile movement, due evidently to induced depression in the rate of ascent. Warm water applied at *H* caused a greater

amplitude of the erectile response. Cold and warm water were subsequently applied in succession, the duration of application being also increased. The increasing responsive fall and erection of the leaf prove conclusively the depression of ascent of sap under cold and acceleration under heat (fig. 196).

In another experiment, the effect of irrigation with water at different temperatures was studied. The rate of ascent induced by water at 34° was found to be two and a half times that by water at 20° C.

EFFECT OF ALTERNATE APPLICATION OF DEPRESSANT AND STIMULANT

Experiment 198.—The leaf, in a condition of balanced turgor, was in a horizontal position. Application of potas-

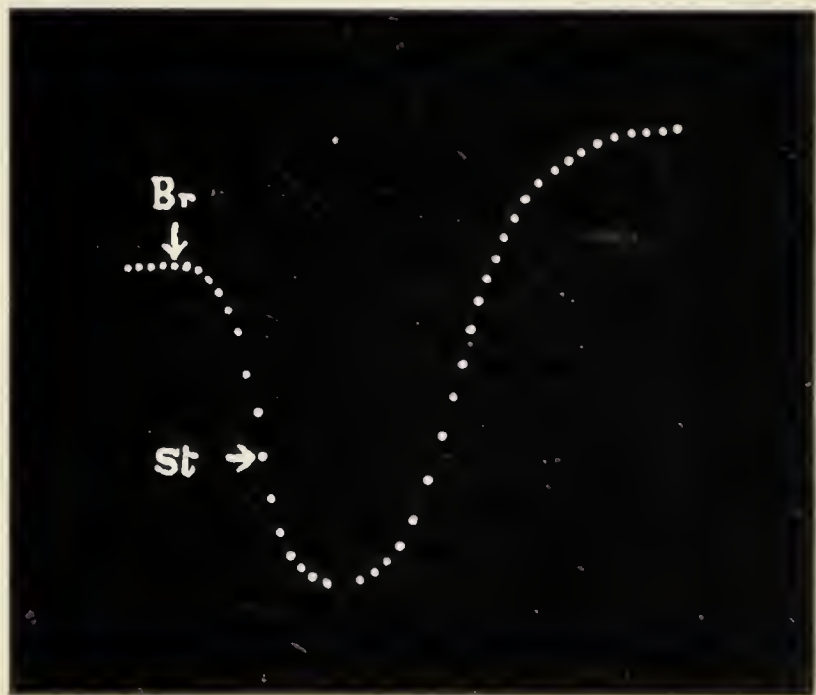

FIG. 197. Alternate arrest and enhancement of ascent of sap by chemical depressant KBr and stimulant Camphor.

sium bromide produced so great a depression that the leaf exhibited a rapid fall. The application of a small dose of camphor, which is a stimulant, produced arrest of the fall

and the subsequent erection of the leaf (fig. 197). These results indicate the characteristic stimulation and depression of propulsive activity induced by drugs.

IRREVERSIBLE ACTION OF POISON

Experiment 199.—The abolition of activity of ascent under poison has been previously demonstrated (*cf.* fig. 192). The following experiment shows the irreversible effect of

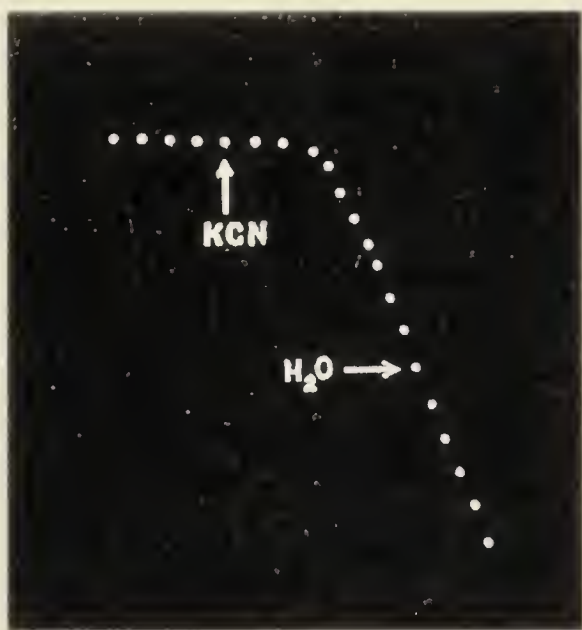

FIG. 198. Toxic effect of KCN solution.

Abolition of ascent of sap by poison caused fall of leaf. Substitution of fresh water at horizontal arrow induced no revival.

poison in arresting ascent of sap as indicated by the responsive fall of the leaf.

As the plant was in a condition of balanced turgor, the initial record given by the leaf was horizontal. Application of very strong poisonous solution of KCN caused the fall of the leaf within a short time. The irreversible action of the poison is shown by the fact that application of fresh water did not arrest the fall (fig. 198): clearly, the ascent of sap had been permanently abolished.

SUMMARY

It has been explained how change induced in the activity of ascent of sap can be detected (1) by the Potograph, which measures the rate of suction, and (2) by the responsive movement of a leaf which is dependent upon the supply of water from the stem. Enhanced activity of ascent of sap in the stem causes an erectile movement, while depressed activity produces a fall of the leaf.

The responsive movements of the leaf, an erection or a fall, are respectively due to the induced increase or diminution of turgor of the leaf-joint ; this is not a passive but an active process. The turgor of a tissue can be increased only when sap is pumped into it ; diminution of turgor, on the other hand, can occur only when sap is removed from it.

Poisonous solutions cause retardation and final abolition of the ascent of sap. This is simultaneously indicated by the continuous diminution of the rate of suction, and by the increasing fall of the indicating leaf. The activity underlying the propulsion of sap is not confined to any particular region, but exists throughout the length of the plant. After the application of poison, successive zones of the living stem are put out of action, resulting in a diminishing rate of ascent and its final abolition.

Physiological changes which enhance the pulsatory activity of the heart and of the *Desmodium* leaflet, also cause an enhancement of the activity of the ascent of sap ; agents which depress the activity of these organs also depress or arrest the ascent of sap.

The activity of the ascent of sap undergoes diminution or arrest in the condition of subtonicity. External stimulation revives the activity, renewing it or enhancing the rate of ascent.

Irrigation with cold water lowers the rate of ascent of sap, while application of warm water enhances it.

Solution of potassium bromide induces its characteristic depression of activity, and thus diminishes the rate of ascent.

A stimulating agent, like a small dose of camphor, revives the activity and enhances the rate.

Poisonous solutions produce permanent abolition of the ascent of sap.

The foregoing results of experimental investigation lead to the conclusion that the movement of sap is dependent upon the action of a physiological, not a physical, force, the source of which is to be sought in the living tissue of the stem, and that the propulsion of sap is maintained by a pulsating mechanism similar to that of the cardiac tissue of the animal and of the pulsating tissue of the *Desmodium* leaflet.

CHAPTER XXIII

THE HIGH MAGNIFICATION SPHYGMOGRAPH

THE movement of sap was indicated, as described in the previous chapter, by the responsive movement of the leaf-indicator. The question arises: Is it at all possible to detect the movement of sap in the stem itself, during the passage of the hydraulic wave?

Taking the somewhat analogous case of changes in the blood-pressure in the artery of an animal, the pressure is found to be increased by enhanced activity of the heart-pump, and lowered by its depression. In the human subject the radial artery is on the surface at the wrist and pressure-variation in it can be recorded by the Sphygmograph, which consists essentially of a series of magnifying levers, at one end of which is a button placed on the artery, and at the other the writing-lever; all that is necessary for a satisfactory record is the proper adjustment of the pressure of the button on the throbbing artery. Such a record would obviously be impossible if the artery, instead of being near the surface, were buried under other tissues.

In the parallel case of the changing sap-pressure in the stem, the channel for transport of fluid (as will be explained later) is the internal cortex, which functions both as the pumping heart and the artery for transport. The passage of an hydraulic wave would theoretically give rise to an expansion of the stem, attended by an increase of lateral pressure, followed by return to its original size, with restoration of the original pressure. The difficulty in the record of variation of sap-pressure in the stem arises from

the fact that the conducting channel, unlike the radial artery, is buried under other tissues ; the area of the channel is, moreover, insignificant compared with the total section of the stem. The alternate dilatation and contraction of the stem produced by the hydraulic wave must therefore be infinitesimal, and may at first sight appear to be beyond means of experimental detection.

THE HIGH MAGNIFICATION SPHYGMOGRAPH

The problem was solved by arranging for a sufficiently high magnification of the infinitesimal changes of pressure at a point in the stem during the passage of the hydraulic wave. Instruments of different degrees of sensitivity were devised for this purpose ; the first, previously described, gives a magnification of 1000 to 5000 times ; the second carries it to 25,000 times, and the third to about 10 million times. The highest magnification is necessary for obtaining the record of the individual pulse-wave in the propulsion of sap. The principle of the High Magnification Sphygmograph will be understood from the diagram (fig. 199). The stem is placed between two rods, one of which is fixed, and the other movable. Two V-shaped pieces of ivory carried by the two rods make contact *c* at diametrically opposite points on the stem. The fulcrum-rod *F* of the movable lever *L* is supported on jewelled bearings. The movable lever is made of porcupine quill, which combines lightness and rigidity in an unusual degree : the inertia of the lever is practically negligible. The pressure of the lever on the stem is adjusted by the spring *S* acting at right angles to the fulcrum-rod. The magnification produced by the first lever is 5 times. This is further magnified by the simple or compound magnifying recording-lever.

The application of water at the cut end of a stem in a state of incipient drought gives rise to an hydraulic wave (in reality to a succession of wavelets) ; this causes dilatation of the responding cortical cells at the sphygmographic

contact along which the sap is being propelled. The dilatation and increase of pressure produce an expansive movement *E* of the lever outwards to the right, contraction producing the opposite movement *C*. In the High Magnification Sphygmograph the movement of the tip of the first lever is further magnified 5000 times by the compound system of levers previously employed in my High Magnification Crescograph; the total magnification is therefore 25,000 times. Under similar magnification the wave-length of

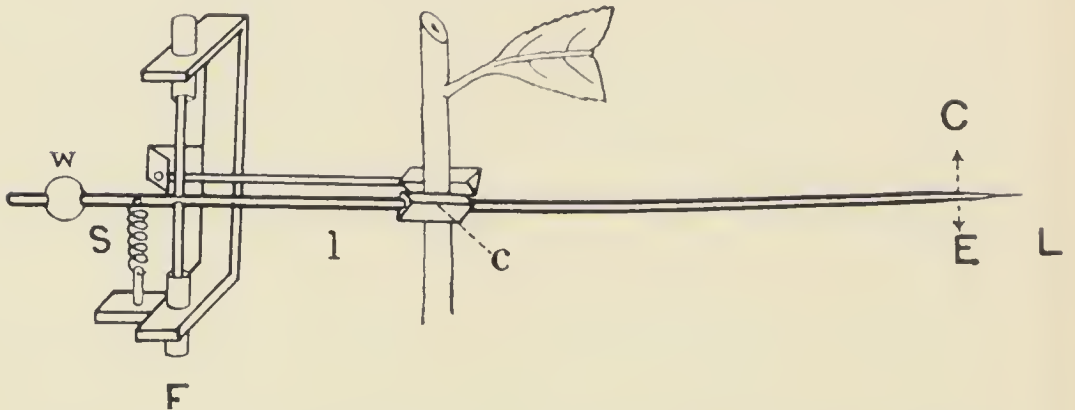

FIG. 199. Diagrammatic representation of Plant-Sphygmograph.

The stem is placed between a fixed rod and a movable lever *L*. Looking from the left, expansion and increase of pressure cause movement of lever towards right *E*, contraction and diminution of pressure bring about movement towards left *C*; *s*, diagrammatic view of spring which acts at right angles to the fulcrum-rod *F*.

sodium light would appear to be lengthened to 12.5 mm. The record is taken on a plate of smoked glass oscillating once in 10 or 20 seconds (fig. 200). Adequate precautions have to be taken against all mechanical disturbance. The whole apparatus is placed on a heavy stand supported by brackets screwed on to the wall. The preliminary test is to mount a dead twig in place of the living stem, when the perfectly horizontal record obtained demonstrates freedom from all disturbance.

I will briefly explain the principle and working of the Plant-Sphygmograph. The turgor of the cortex at the sphygmographic point of contact is in a balanced condition

when the quantity of sap brought up from below is equal to that removed by the transpiration-current. On withdrawal of the supply of water, the accession of sap is arrested while the loss persists. The result is an increasing contraction and diminution of pressure recorded by, say, a down-curve; an up-curve indicates an expansion and increase of pressure.

A shoot is taken in a state of drought; the cut surface at its lower end is touched with dilute glycerine to prevent

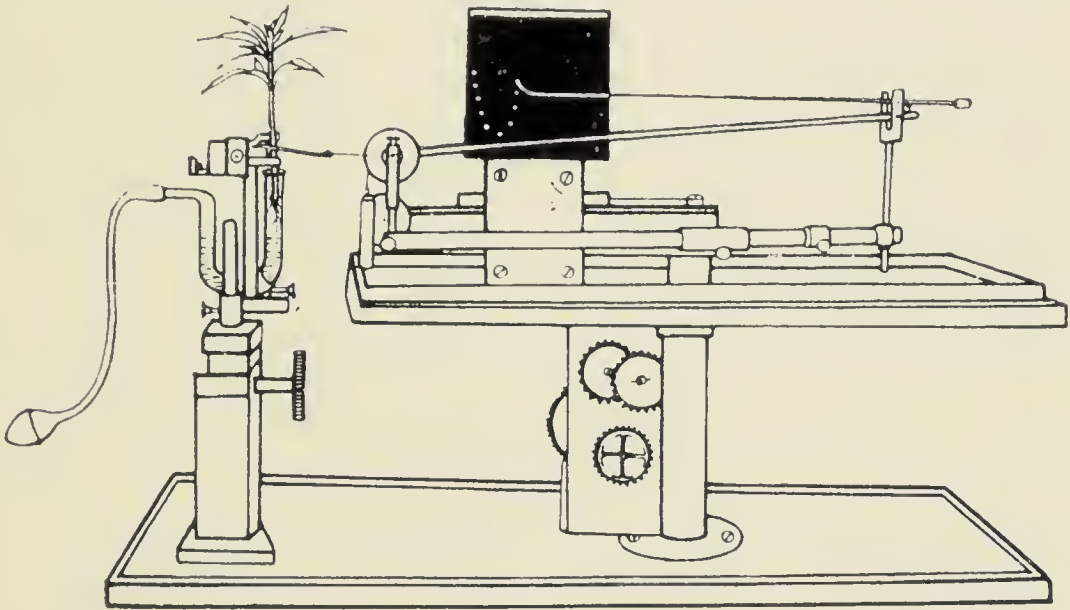

FIG. 200. The High Magnification Sphygmograph.

Movement of sphygmographic lever highly magnified by compound levers and recorded on oscillating smoked plate of glass. Water is applied at the cut end of stem by pressure of indiarubber bulb.

rapid drying of the exposed cells. The shoot is suitably mounted on the apparatus in a U-tube partially filled with water or other solution. By manipulating the pressure-bulb, the water can be successively applied to or withdrawn from the cut end of the stem for definite lengths of time.

Under drought, the increasing diametric contraction of the stem is, as explained, shown by a down-curve. Application of water for a definite length of time gives rise to an hydraulic wave, which, on reaching the small group of responding cells at the contact, causes a brief dilatation and increase

of pressure shown by an up-curve (*see* fig. 201). The latent period, or delay in responsive dilatation, depends on the intervening distance and on the activity of the ascent of sap. The expansion caused by the passage of the brief hydraulic wave beyond the contact is then followed by contraction. The sphygmogram of a brief hydraulic wave consists of an up- followed by a down-curve.

UNIFORM SPHYGMOGRAMS

Experiment 200.—Successive responses of equal amplitude were produced by application of water for equal lengths of time. Uniform sphygmograms were obtained with a large number of herbaceous plants, such as *Impatiens*,



FIG. 201. Uniform sphygmograms of young stem of *Leucosceptrum* tree.

Duration of application of water represented by thick lines below.
Successive dots at intervals of 20 seconds.

Cosmos, *Centaurea*, *Chrysanthemum coronarium*, and the young stem of the tree *Leucosceptrum canum*. Two successive uniform responses of the tree-stem are given in fig. 201. The effect of change of external conditions is manifested, as in the following experiments, by appropriate changes in the amplitude of response.

EFFECT OF CHANGE OF TEMPERATURE

Experiment 201.--A rise of temperature has been shown to enhance the activity of ascent (Experiment 197). In the

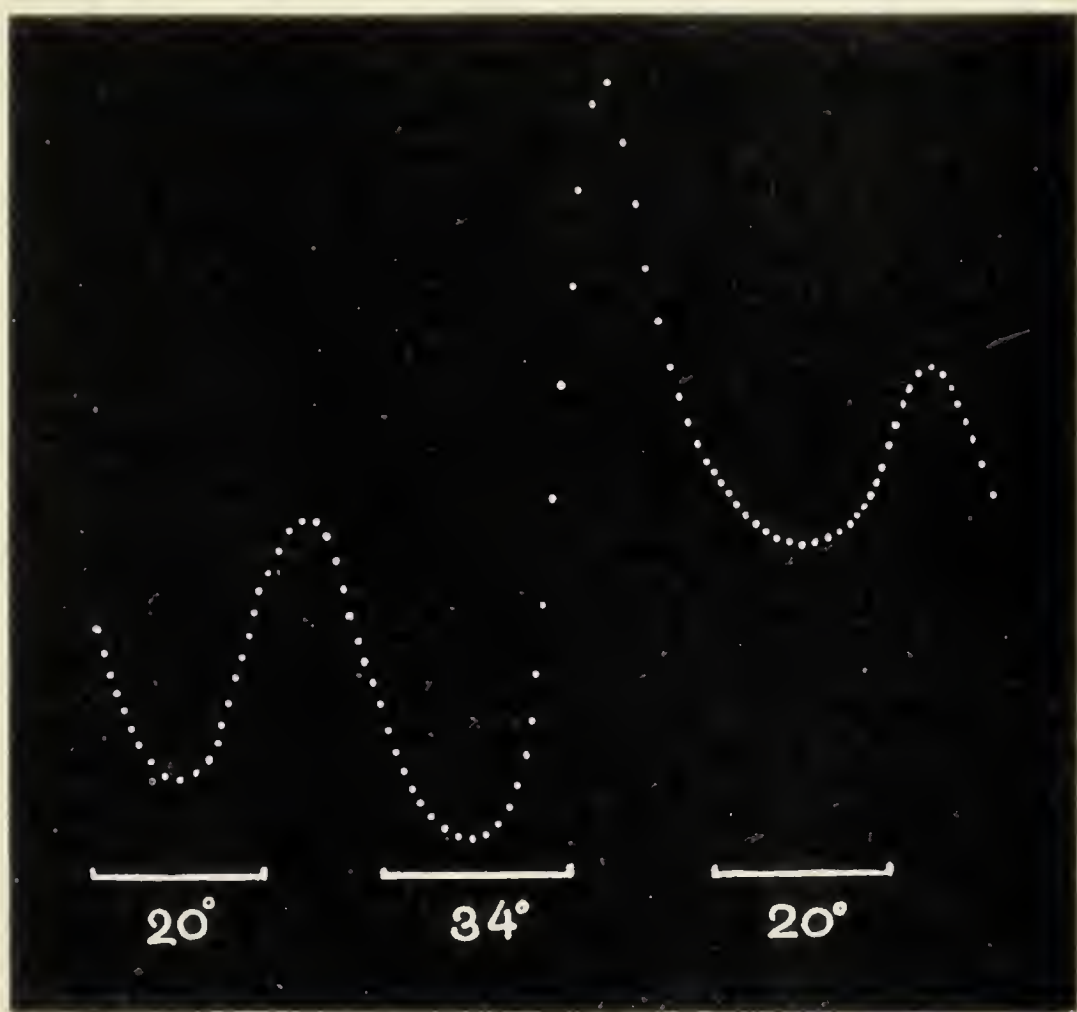

FIG. 202. Effect of variation of temperature on p. opulsive activity (sphygmograms).

The feeble activity at 20° is increased at 34° C. and decreased once more at 20° C.

present case three successive hydraulic responses were obtained for applications of equal duration of water at 20°, at 34°, and once more at 20°. The amplitude of response at 34° was very much larger than that at 20° (fig. 202). The recovery from enhanced response was incomplete within the time allowed, hence the base-line is displaced upwards.

Owing to physiological *hysteresis*, the response after a cycle of experiments is not exactly the same as at the beginning.

EFFECT OF VARIATION OF THE TRANSPIRATION-CURRENT

I describe the effect of change in the rate of transpiration on the propulsive activity of the stem, as recorded by the Sphygmograph.

Experiment 202.—I took a stem of *Centaurea*, bearing ten leaves, in a state of incipient drought; the distance between the cut end of the stem and the sphygmographic contact was 25 mm. Water was applied for a definite short period at the cut end, and the resulting hydraulic wave reached the active cells at the sphygmographic contact in the course of 10 seconds; the peristaltic wave not only arrested the increasing contraction under drought, but reversed it into dilatation, which continued for 10 seconds, even after the withdrawal of water. The amplitude of response was 53 mm. and the recovery to the original pressure was completed in the course of 3·5 minutes.

Experiment 203.—The loss by transpiration was then reduced by the removal of six out of the ten leaves. The latent period for the responsive dilatation was now reduced from 10 to 5 seconds, and the amplitude of response increased to 118 mm. The expansive reaction persisted for 110 seconds after the removal of water-supply, and the period of recovery to original pressure was prolonged from 3·5 to 9 minutes. The difference due to change in the rate of transpiration is shown in the following table:

TABLE XVIII.—EFFECT OF CHANGE IN TRANSPIRATION ON RESPONSE.

Condition	Amplitude of response	Persistence of dilatation	Recovery
Active transpiration	53 mm.	10 seconds	3·5 minutes
Enfeebled ,,	118 ,,	110 ,,	9 ,,

The difference may be explained by comparing the stem with an elastic indiarubber tube into which water pumped from below escapes at the upper end through a vent, the aperture of which can be increased or diminished. The responsive dilatation is slight when the vent is large, and the restoration of the tube to its original form takes place quickly on cessation of pumping. If the vent be reduced, the same duration of pumping will cause a greater dilatation, and the recovery of the pipe to its original form will be greatly prolonged. In a plant with numerous leaves, the vent for escape of water is large, while it becomes reduced when a number of them are removed.

SIMULTANEOUS SPHYGMOGRAM AND PHYTOGRAM

I now offer experimental evidence to prove that the passage of the hydraulic wave is brought about by cell-to-

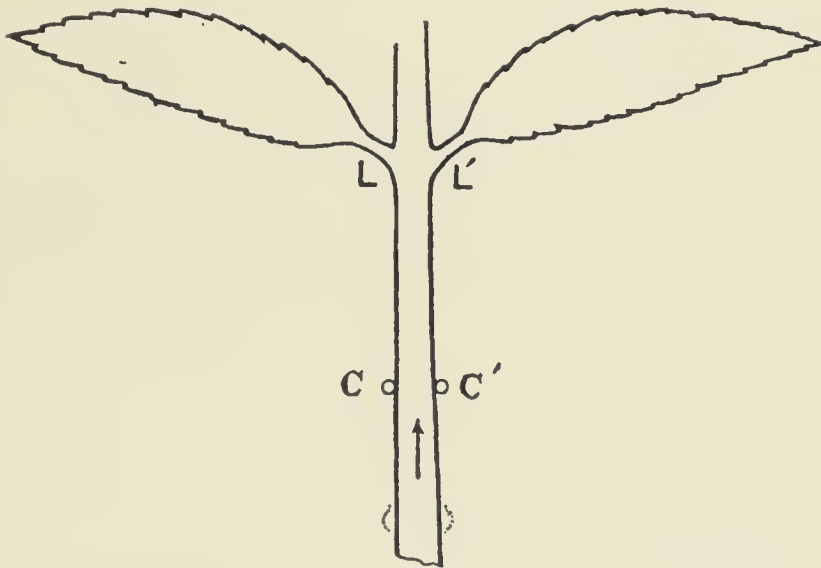

FIG. 203. Diagram of passage of hydraulic wave from cut end of stem to leaf above.

c c', sphygmographic contacts; L L', indicator-leaves giving the phytographic record (*Impatiens*).

cell transfer of sap along the propulsive layer which is continuous in the stem and in the leaf. This is demonstrated by the definite sequence of the responses which occur at two

points distant from each other. The method of experiment is explained by the diagram (fig. 203). The hydraulic wave initiated by the application of water for a short time to the cut end of the stem (*Impatiens*) in a state of drought, first reaches the contact-points CC' in the stem, the response being recorded by the Sphygmograph, and then travels on to the leaves $L L'$, the response of one of which is recorded by the Phytograph (*cf.* fig. 203).

Experiment 204.—The two records (fig. 204) show that the passage of the same hydraulic wave produced response first of the stem at the sphygmographic contact (lower record), and then of the leaf higher up (upper record). The moment of application of water is indicated by the vertical line. The hydraulic wave reached the sphygmographic contact 80 seconds after application of water and produced dilatation. After the passage of the wave beyond the contact, the down-curve indicated contraction and diminution of pressure. The upper record, as already stated, is the phytogram of the indicating leaf, recording the passage of the same hydraulic wave. It will be noticed that the leaf-response occurred 60 seconds later, which is the time required for the ascent of sap through the intervening distance of 80 mm. The velocity of transport was 1.3 mm. per second, which is the average rate in the stem of *Impatiens* at that particular season of the year, as found from other experiments.

The fact that the phytogram is practically a replica of the sphygmogram proves conclusively that the *propulsive mechanism is identical in the stem and in the leaf, the characteristic responses of expansion and contraction being due in each case to absorption or expulsion of sap by an active tissue.* In the records given, the movement at the leaf-joint was magnified 300 times, that at the stem-contact 25,000 times. The amplitude of the two responses is nearly the same; hence the anisotropic leaf-joint, with its larger mass of cortex, gives a response about 100 times greater than that given by the stem with its few layers of cortex at the contact-point.

The fact that there is continuity of contractile tissue in the leaf-joint and the stem has already been demonstrated by records of the contraction of the cortical cells in



FIG. 204. Simultaneous sphygmogram (lower record) and phytogram (upper record) (*Impatiens*).

Vertical line represents moment of application of water. Phytographic response initiated 60 seconds later than the sphygmographic, this being the time of transmission through the intervening distance. Successive dots are 20 seconds apart.

different regions of the plant in response to electric stimulation (Experiments 72, 74).

I have in a previous chapter described the peristaltic propulsion of the contents of the stomach by waves of contraction. It was further shown that the velocity of the wave is about 4 times quicker in the normal peristaltic than in the opposite antiperistaltic direction.

It will be shown later that the propulsion of the sap is likewise a case of peristaltic action. Does the sap always flow in one direction or can it be made to undergo a reversal? If so, is there any difference in the rate of flow in the two directions?

TRANSPORT OF SAP IN NORMAL AND IN REVERSED DIRECTION

By the sphygmographic method, clear demonstration has been obtained that the propulsion of sap not only takes place in the normal upward direction but can be reversed into the downward direction.

Experiment 205.—The specimen was a stem of *Chrysanthemum coronarium* in a state of drought, from which both the leaves and roots had been removed. The normal velocity of ascent is considerably higher in *Chrysanthemum* than in *Impatiens*. The bare stem, 8 cm. in length, was coated, except at the upper and lower ends, with impermeable varnish. The contact-point of the Sphygmograph was midway, *i.e.* 4 cm., from either end. Water was applied alternately above and below by touching the ends with a piece of moist cloth. The movement of sap was downwards in the first case, and upwards in the second.

INTENSITY OF TRANSMITTED IMPULSE IN TWO DIRECTIONS

The first response was obtained when water was applied at the upper end for 3 minutes. The latent period for transmission through 4 cm. was 80 seconds, the velocity in the downward direction being 0.5 mm. per second, and the amplitude of response was 8 mm. The second response was to the application of water at the lower end for 1 minute; the period of application had to be reduced, as otherwise the record would have gone off the plate. The latent period was 12 seconds, the velocity in the normal upward direction being 3 cm. per second. This gives the ratio of the velocities in down and up directions as 1 : 6. The more

effective upward transmission is also demonstrated by the more erect form of the up-curve of the second response; the amplitude of response in this case to the application for 1 minute was 23 mm. (fig. 205): for 3 minutes' application, it would have been over 50 mm. or so, the ratio of the two amplitudes being of the order 1:6; that is, the trans-

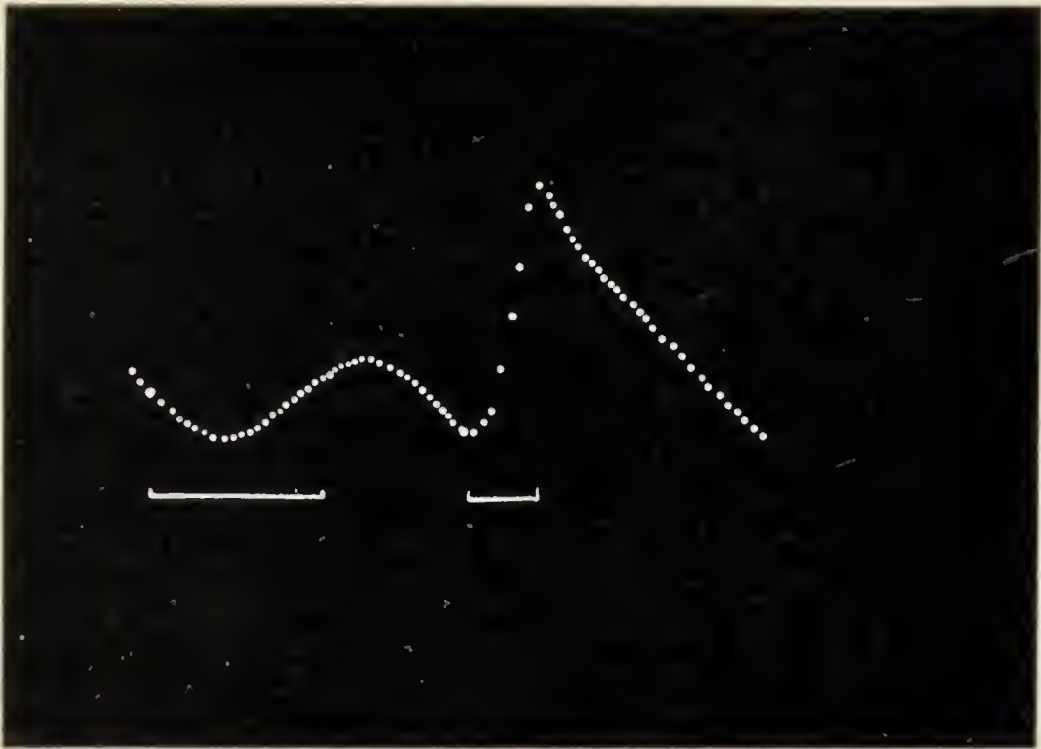

FIG. 205. Sphygmograms of descending and ascending hydraulic waves in a bare varnished stem, caused by successive application of water above and below.

Thick horizontal line below first response represents duration of application of water at upper end of stem. The line below second response denotes the duration of application of water at lower end of the stem (*Chrysanthemum*).

mitted impulse in the normal direction was about 6 times more intense than that in the reverse or unusual direction. A different method (Experiment 216) gave results which are practically the same as the above.

The important fact established is that the sap-movement can take place in a stem from which leaves and roots have been removed; the transport of sap can occur, moreover, not only in the normal upward but also in the reverse

downward direction. The results described completely demolish the hypothesis generally held that the movement of sap depends upon the activity of the terminal organs, the suction exerted by leaves from above, and the pressure exerted by the roots from below.

The significance of these results will be fully appreciated in a subsequent chapter where I deal with the subject of peristaltic and antiperistaltic waves in plants.

PERIODIC VARIATION OF SAP-PRESSURE

The Sphygmograph also makes possible the determination of the periodic variation of sap-pressure in the stem of the plant. This is by no means a simple but is a highly complex phenomenon, for the pressure exerted by the sap is modified by the varying factors of accession of water from the soil and its loss by transpiration from the leaves. It is to be remembered that every section of a tree possesses rhythmic activity which, within limits, is enhanced by a rise of temperature. There are the two extreme cases, (1) of a tree with a large number of leaves, and (2) of a tree without leaves. In the first case, though rise of temperature causes enhanced absorption by the root and quicker ascent along the stem, the loss of water by transpiration from the numerous leaves is even greater. Hence the sap-pressure in leafy trees is minimum at the hour of the day when the temperature is at its highest, this period being conveniently described as the thermal noon, which is attained between 12 noon and 3 P.M. according to the season. The loss of water by transpiration is minimum at thermal dawn at about 6 A.M., when the temperature is at its lowest point. The sap-pressure is therefore at its maximum at or about 6 A.M. In leafless trees, on the other hand, the rise of sap increasing with rise of temperature (there being no loss by transpiration) causes maximum sap-pressure at thermal noon and minimum pressure at thermal dawn. The diurnal variation of sap-pressure in leafless trees is therefore the

reverse of that of leafy trees. These facts were established by records of diurnal variation of pressure inscribed by the Self-recording Manometer.¹

I now proceed to determine the diurnal variation of sap-pressure by the independent method of the Sphygmograph.

SPHYGMOGRAPHIC RECORD OF DIURNAL VARIATION OF SAP-PRESSURE

An increase of sap-pressure in the stem at any particular period of the day will involve diametric expansion of the cortex, and a diminution will produce contraction; these periodic changes will recur day after day. Any permanent expansion in diameter by growth in the course of 24 hours would be too slight to affect the record with moderate magnification.

DIURNAL VARIATION OF SAP-PRESSURE IN LEAFY TREES

Experiment 206.—The specimen employed was a young Mango tree about 60 cm. in height. The stem bore a rosette of six leaves at the top; the sphygmographic contact was made a short distance below the leaves. The magnification employed was at first 2000 times. This gave records of diurnal variation of pressure which were very definite and of so great an amplitude that it would have been impossible to reproduce them within the page. I therefore reduced the magnification to 1000 times. The experiment was commenced at 6 P.M. The upper record is that of the thermal variation, fall of temperature being recorded as an up-curve. In the lower record, which is that of the diurnal variation of pressure, diametric expansion with rise of pressure is indicated by the up-curve and contraction with diminution of pressure by the down-curve (fig. 206).

Inspection of the temperature-curve shows that the lowest

¹ *Physiology of the Ascent of Sap*, pp. 156, 165.

temperature (19.5° C.) was attained at 6 A.M., while the highest temperature (26° C.) was reached at 12 noon. The turning-point of temperature from fall to rise is therefore at 6 A.M., and that of rise to fall is at 12 noon.

Comparison of the curves of temperature and pressure shows a very striking correspondence. The fall of temperature between 6 P.M. and 6 A.M. was attended by an increase



FIG. 206. Diurnal variation of sap-pressure in leafy tree.

The upper is the thermographic record, up-curve representing fall of temperature. The lower is the record of variation of pressure, the up-curve representing expansion and increase of pressure (Mango).

of sap-pressure. The thermal reversal took place at 6 A.M. and the reversal of sap-pressure occurred at about the same time, 6.45 A.M., the delay being due to physiological inertia. The second reversal occurred at noon and, corresponding to this change from rise to fall of temperature, there was a variation from diminished to increased pressure shortly after noon (fig. 206).

The results of sphygmographic investigation are thus fully concordant with those obtained by the Manometric Method.

DIURNAL VARIATION OF SAP-PRESSURE IN LEAFLESS TREES

Experiment 207.—In order to investigate the effect of a reduction of transpiration, the experiment was continued with the same specimen (Mango) after removal of all the leaves. It was very interesting to note that the old rhythm persisted, more or less, for several days according to the



FIG. 207. Diurnal variation of pressure in leafless tree.

Note the reversed record compared with that of the leafy tree. Maximum sap-pressure at thermal noon, and minimum pressure at thermal dawn (Mango).

habit that had been impressed on the organism. On the fourth day, however, the diurnal variation exhibited a complete reversal, the maximum pressure and expansion being attained at thermal noon and the minimum at thermal dawn (fig. 207). This agrees with the variation of sap-pressure in leafless trees as recorded by the Manometer.

SUMMARY

The effect of any slight variation of sap-pressure can be recorded by the Plant-Sphygmograph with a magnification of 25,000 times. Accession of sap at any point in the cortex

of the stem is attended by expansion and increase of pressure. Removal of sap is, on the other hand, followed by contraction and diminution of pressure.

The amplitude of the response recorded by the Sphygmograph increases, within limits, with rise of temperature.

Change in the rate of loss of water by transpiration appropriately modifies the sphygmographic record.

Simultaneous record of the diametric expansion or contraction of the stem and of the responsive up- and down-movement of the leaf due to the passage of the same hydraulic wave shows that the phytogram is a replica of the sphygmogram. This proves that the cellular mechanism is identical in the stem and in the leaf, the characteristic responses of expansion and contraction being due to absorption or expulsion of sap from the cortical tissue in both. Continuity of contractile cells through the length of the plant has also been demonstrated.

The sap moves not only in an upward direction, but can be made to flow in the reverse or downward direction. The transference of sap in the normal upward direction is about 6 times more rapid than that in the unusual downward direction.

By means of the Sphygmograph it is possible to record the diurnal variation of sap-pressure in the stem. In a leafy tree, under normal conditions, the sap-pressure is maximum at thermal dawn, at about 6 in the morning; it is minimum at thermal noon. In a leafless tree the above relation is reversed; the maximum pressure is attained at thermal noon and the minimum at thermal dawn.

These characteristic results confirm my previous manometric results on the variation of sap-pressure.

CHAPTER XXIV

ELECTRIC RECORD OF CELLULAR PULSATION IN THE PROPULSION OF SAP

THE experiments described in the previous chapters prove that there is an active tissue somewhere in the interior of the plant, the pulsation of which effects the propulsion of the sap in the plant, just as the pulsation of the heart maintains the circulation of the blood in the animal.

The question arises whether it is possible to localise this pulsating layer in the plant, and to obtain an actual record of cellular pulsation by which the movement of sap is maintained. The problem was solved by the employment of an electric method, the principle of which will be understood from the following experimental demonstration.

It has been shown in a previous chapter that when an electric contact is made with a resting tissue of the plant, the galvanometer in circuit remains quiescent. But when the tissue undergoes a sudden contraction under stimulation, an electric change of galvanometric negativity occurs, shown by a deflection of galvanometer in one direction. Expansion of the tissue during recovery produces a deflection in the opposite direction.

The pulvinule of the leaflet of *Desmodium gyrans* exhibits automatic contraction and expansion of its cortical cells, as shown by the pulsatory up- and down-

movements. I have shown in earlier publications that these movements are accompanied by corresponding electric pulsations.

ELECTRIC PULSATION OF PULVINULE OF DESMODIUM

Experiment 208.—Two electric connexions were made, the first with the more excitable lower half of the pulvinule, and the second with a distant indifferent point on the stem, a sensitive galvanometer being interposed in the circuit (fig. 208). The records of mechanical and electric

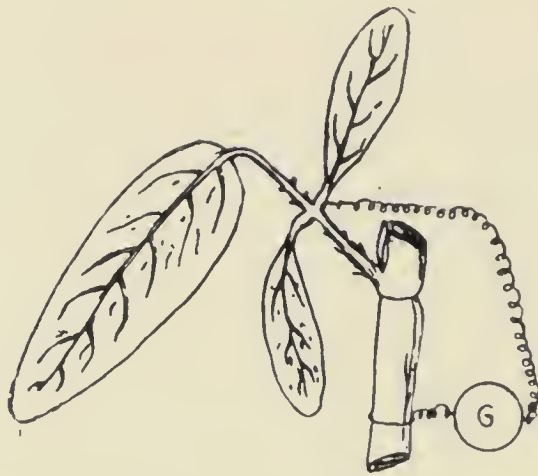

FIG. 208. Method for record of electric pulsation of pulvinule of *Desmodium*.

Electric connexions made one contact with the pulsating pulvinule, the other contact with an indifferent point on the stem.

pulsations taken simultaneously show that the electric record is practically a replica of the mechanical (fig. 209). The fact that the electric pulsation is due to an underlying cellular pulsation, and not to the movement of the leaflet, was demonstrated by holding it in a fixed position; the electric pulsation was nevertheless found to persist. The experiment described proves that :

- (1) A resting non-rhythmic tissue exhibits no electric pulsation.

- (2) Rhythmically pulsating tissue exhibits, on the other hand, automatic electric pulsation.
- (3) Conversely, electric pulsation indicates rhythmic contraction and expansion in the tissue.

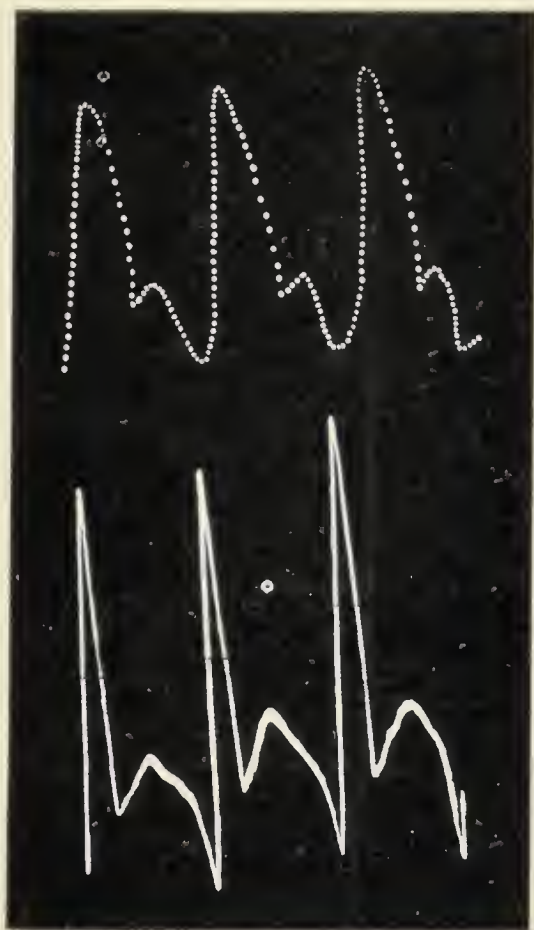

FIG. 209. Simultaneous record of mechanical pulsation (upper figure) and corresponding electric pulsation (lower figure) of pulvinule of *Desmodium*.

I have obtained similar results, by the same method, with the propulsive tissue of the stem.

LOCALISATION OF THE PROPULSIVE TISSUE

Experiment 209.—In order to localise the tissue active in the propulsion of sap, I introduced the Electric Probe (insulated except at the tip) transversely into the stem of

Impatiens by successive steps of $\cdot 05$ mm. (fig. 210). No pulsation was observed in the epidermis or in the sub-epidermis; but when the probe reached the internal cortex abutting on the vascular tissue, evidence of pronounced rhythmic activity of the tissue was given by electric pulsations (fig. 211); the pulsations disappeared when the probe came in contact with the xylem, which does not, therefore, take any active part in the propulsion of sap.¹

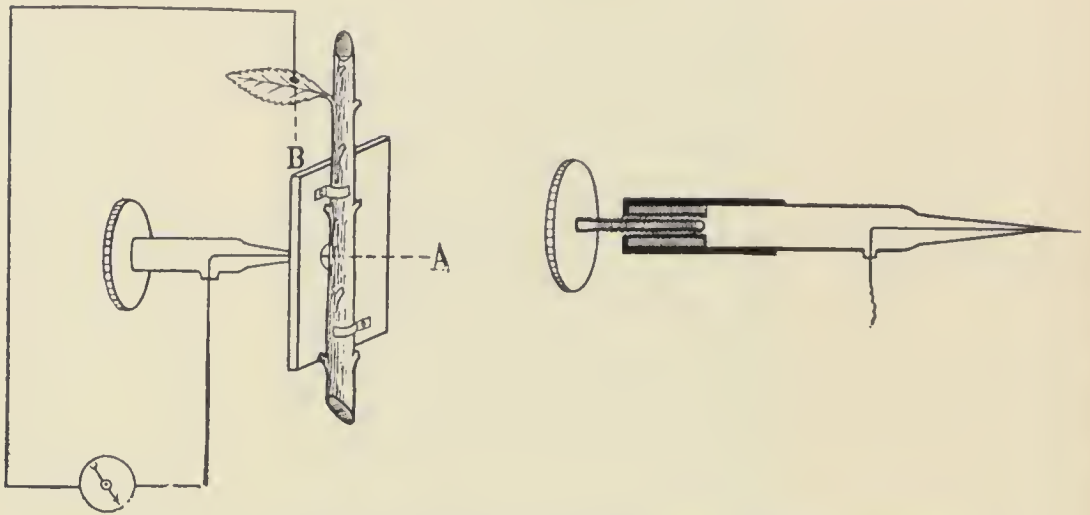

FIG. 210. The Electric Probe for the localisation of the pulsating tissue in the stem.

The point of the Probe enters the stem at A, the second electric contact being made with a distant leaf. The figure to the right is an enlarged view with the micrometric screw for the gradual introduction of the Probe into the tissue of the plant.

These and other results to be presently described offer conclusive proof that the ascent of sap is brought about by the pulsating activity of a propulsive layer situated in the inner cortex surrounding the vascular tissue. It should, however, be borne in mind that under exceptional circumstances all living cells are capable of being thrown into

¹ 'The inactive xylem vessels are situated very near the cortex within a fraction of a mm. or so; hence it is easy for the active cortex to force the sap laterally into the xylem during the phase of contraction. The xylem may therefore be regarded as a reservoir, water being pumped into or withdrawn from it according to the different circumstances.'—*Physiology of the Ascent of Sap* (1923), p. 38.

rhythmic activity; certain layers of cells are, however, naturally more active than others, and it is by the exceptionally high automaticity of such cells in the inner cortex that the rapid propulsion of sap is maintained.

In an ordinary non-rhythmic cell the state of turgor is normally constant, and its electric potential therefore



FIG. 211. Record showing the amplitude of electric pulsation in different layers of stem of *Impatiens*.

Note the abrupt enhancement at a distance of 0.3 mm. from the surface, the particular layer being in the inner cortex; a portion of the record has gone out of the plate.

remains unchanged. But in a pulsating cell there is a series of changes of turgor with alternate expansion and contraction, indicated in the record by up-strokes and down-strokes. The phase of increased turgor is accompanied by a positive, and of diminished turgor by a negative, electric variation. The galvanometer spot of light thus reveals, by its alternate swings to the right or to the left, the invisible pulsations of the active cells in the interior of the plant.

TABLE XIX.—MECHANICAL AND ELECTRIC RECORDS DURING ONE COMPLETE PULSATION.

Record of phasic change	Turgor variation	Mechanical response	Electric response
Up-stroke	Increase of turgor	Expansion	Electro-positivity
Down-stroke	Diminution of turgor	Contraction	Electro-negativity

ELECTRIC PULSATION IN THE CORTEX

The electric pulsations in the cortex can be recorded without much difficulty. One of the conditions for obtaining a satisfactory record is the electromotivity of the tissue,

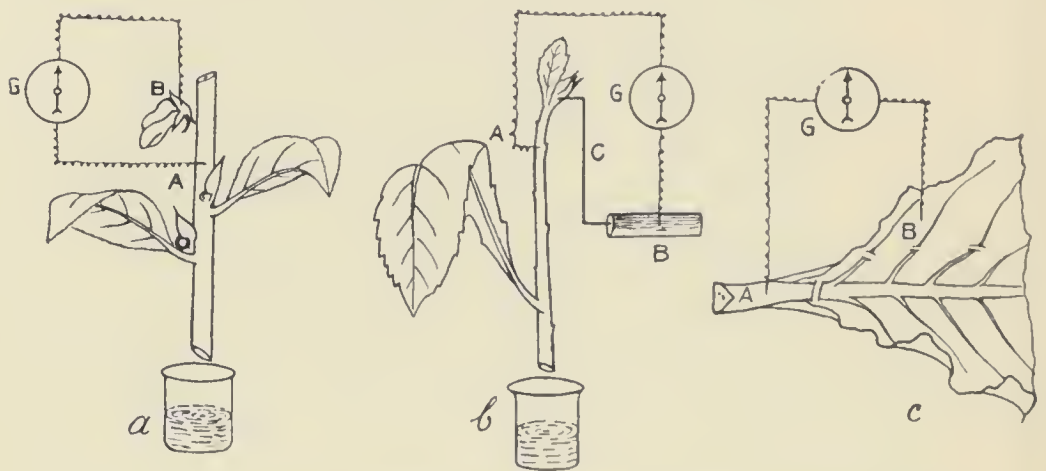

FIG. 212. Electric connexions for record of electric pulsation of the propulsive layer.

A, connected in all cases with the Electric Probe. The second connexion, B, with the indifferent point is made a floral contact in *a*, a physiologically isolated contact in *b*, and a laminar contact in *c*.

by which is meant the intensity of the electric variation induced by cellular expansion or contraction. In this respect, certain plants give better results than others. The second and most important condition is that while one of the two electric contacts is on the cortex of the stem, the other should be made with an indifferent point which is

unaffected by changes in the rate of ascent of sap in the stem. The indifferent point may be (1) a floral contact, (2) a physiologically isolated contact, or (3) a laminar contact.

Floral Contact.—The distant indifferent contact B is made with a petal of a flower in which there is little venation (fig. 212, a).

Isolated Contact.—A distant indifferent point is better secured by physiological interruption between the two contacts. Two separate pieces of stem (one shown vertical and the other horizontal) are electrically connected by a silver wire C. It is obvious that changes of turgor in A cannot produce any change in B (fig. 212, b).

Laminar Contact.—A suitable specimen for this is the leaf of Brassica; contact A is made on the midrib in which conduction of sap takes place; contact B is made on the lamina, to which the supply of sap is interrupted by cutting across a number of the lateral veins (fig. 212, c).

Employing one or other of the three methods, the galvanometric record of the electric pulsations was taken on a moving photographic plate. Under conditions of balance and uniform external conditions, the pulsations are practically uniform, the up-stroke of galvanometric positivity indicating cellular expansion being equal to the down-stroke of galvanometric negativity indicating contraction (fig. 213).

It has been shown in previous chapters that all conditions which stimulate the pulsatory activity of the Desmodium leaflet or of the animal heart also enhance the activity of the ascent of sap; other conditions which depress the pulsatory activity of those organs induce depression or arrest of the ascent. Having discovered that the inner cortex of the stem is the actively pulsating layer, it can be shown that

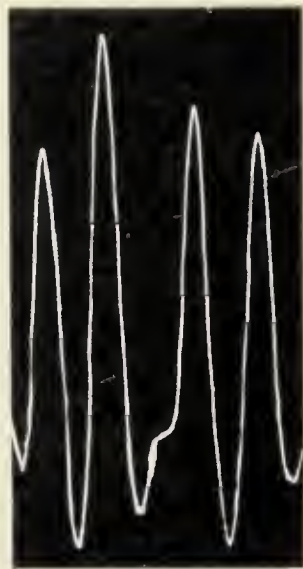

FIG. 213. Record of uniform electric pulsation in the Mango tree.

enhancement and depression of the pulsatory activity of that layer (as manifested by corresponding modification of the electric pulsation) induce corresponding variations in the rate of ascent of sap.

EFFECTS OF DIMINISHED AND INCREASED INTERNAL PRESSURE

Desmodium pulsation.—The effect of diminished internal pressure under drought in arresting the pulsation of the *Desmodium* leaflet, and the revival of pulsation after irrigation,

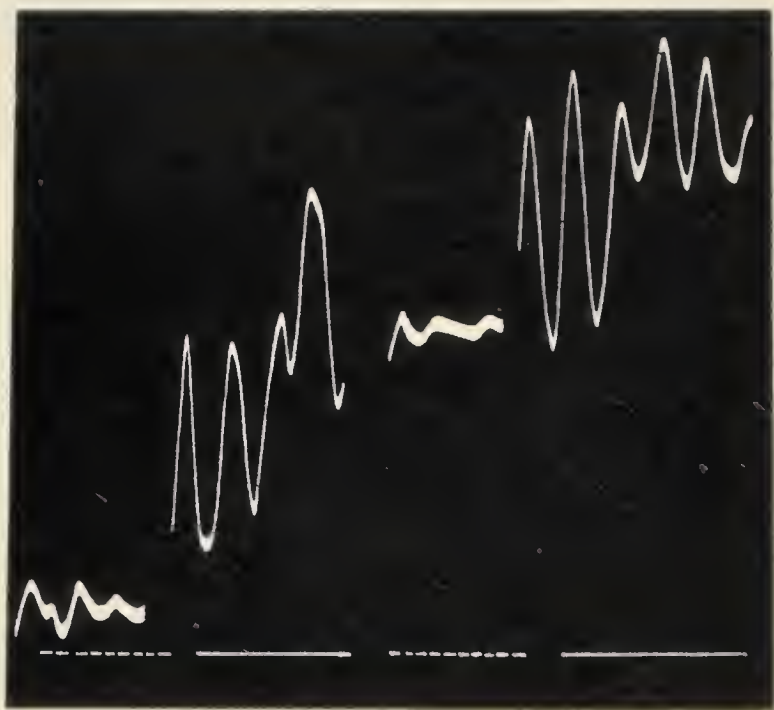

FIG. 214. Record of electric pulsation under alternate drought and irrigation (stem of *Impatiens*).

Up-curve indicates electric positivity; down-curve, electric negativity. Dotted line below represents condition of drought, continuous line indicates irrigation.

have already been shown (*see* fig. 157). Drought and irrigation similarly affect pulsation of the propulsive layer as indicated in the electric record.

Experiment 210. *Electric pulsation in stem.*—The record of the electric pulsation of the propulsive layer in the stem of *Impatiens* is given in fig. 214. The first record was taken

in a condition of drought, the pulsation being extremely feeble; on irrigation the pulsatory activity is seen to have been greatly enhanced, as shown by the increase in the amplitude of electric pulsation, which was repeatedly depressed under drought and revived after supply of water (*see also* fig. 92).

EFFECT OF VARIATION OF TEMPERATURE

Desmodium pulsation.—The pulsation of *Desmodium* exhibited arrest at a low temperature, and revival when the temperature rose above the critical thermometric minimum (*cf.* fig. 165).

Experiment 211. *Electric pulsation in stem.*—I took a cut shoot of *Centaurea* in a condition of drought. The pulsation was very feeble, but application of water at 20° at the cut end of the stem caused a revival. The pumping activity was arrested by substitution of cold water at 5° for water at 20°, the electric pulsation showing a great depression. Irrigation with warm water once more revived the electric pulsation.

The mechanical effect of alternate application of cold in depressing and of heat in enhancing the rate of ascent has already been demonstrated (*cf.* fig. 196).

EFFECT OF SUBTONIC CONDITION

Desmodium pulsation.—When the plant is kept in the dark for 24 hours, it becomes so subtonic that its pulsatory activity comes to a stop; stimulation by electric shock or by light was found to revive the arrested activity (*cf.* figs. 143, 144).

Experiment 212. *Electric pulsation in stem.*—The electric record affords a clear insight into the phenomenon of propulsive pulsation. A cut shoot kept in a dark chamber for 24 hours became so subtonic that the electric pulsation became enfeebled almost to extinction. The throbbing activity was, however, revived on stimulation by light,

and arrested once more on the cessation of the stimulus (fig. 215).

Very interesting characteristics of the cellular mechanism are revealed in this record. The up-stroke of each electric

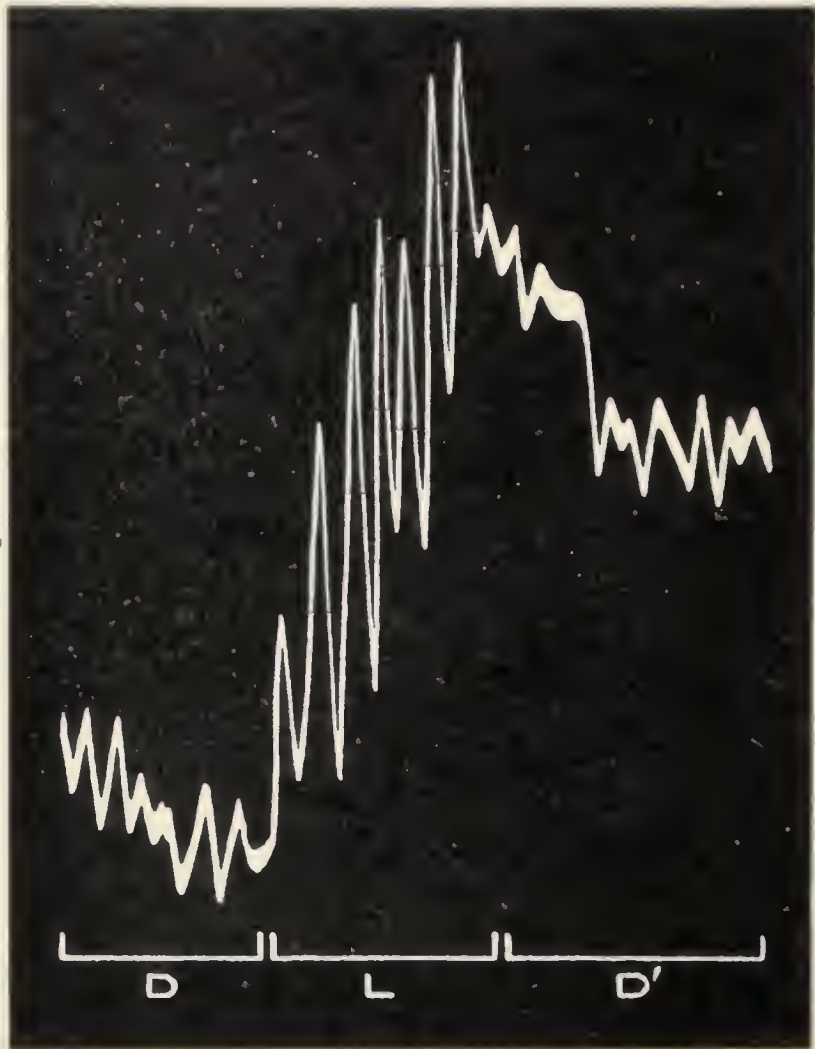

FIG. 215. Effect of stimulus of light enhancing electric pulsation in a subtonic specimen (*Impatiens*).

D, feeble pulsation in dark; L, enhanced pulsation under light; and D', depression under renewed darkness.

During stimulation the up-stroke of each pulsation is larger than the down-stroke, with resulting displacement of base-line upwards.

pulsation indicates expansion and absorption of sap, while the down-stroke exhibits contraction and expulsion of sap; when these two are equal, the tissue, as previously explained,

is in a state of balanced turgor. But under the enhanced activity induced by the stimulation, the up-stroke indicating absorption of sap is larger than the down-stroke exhibiting expulsion. The residual effect of the enhancement of the turgor of the tissue is therefore manifested in the increased electric positivity of the tissue which is indicated by the displacement of the base-line upwards.

I have already described (Experiments 195, 196) the effects of photic and electric stimulation in reviving or enhancing the activity of the ascent of sap in subtonic specimens (*cf.* figs. 194, 195).

PERISTALTIC WAVE IN THE UNIDIRECTIONED PROPULSION OF SAP

The unidirectioned propulsion of sap depends upon a sequence of pulsation from cell to cell. This has been demonstrated by the occurrence of definite electric maxima in the channel of transport, the distance between the maximum and the minimum being half the wave-length.¹ The sap expelled during the contraction of any one cell is absorbed by a cell higher up during its phase of expansion. A succession of such peristaltic waves maintains the continuous ascent of sap.

SUMMARY

It has been shown that automatic electric pulsations, corresponding to the mechanical pulsations, are exhibited by the pulvinule of the *Desmodium* leaflet. The electric pulsation persists even when mechanical movement is restrained.

Electric pulsation indicates automatic cellular contraction and expansion in the tissue.

A tissue giving electric pulsations was discovered in the stem by the Electric Probe; it was localised in the inner cortex.

¹ *Physiology of the Ascent of Sap*, p. 225.

Conditions which stimulate or depress the electric pulsation of this tissue cause parallel modifications in the rate of ascent of sap. Hence it is concluded that this pulsating layer is the propulsive tissue effecting the rapid ascent of sap.

It has been shown that the fundamental rhythmic activity finds external expression in both mechanical and electric pulsations ; in change in the rate of the ascent of sap ; and in variation of bulk of the tissue, either expansion or contraction.

CHAPTER XXV

THE INDEPENDENT MOVEMENT OF SAP

THE experiments in the previous chapter prove that the movement of the sap is brought about by the pulsatory activity of living cells which exert a pumping action ; but something still remains to be explained. If the cellular pumps in the plant simply underwent periodic contraction and expansion, the sap would merely move forward and backward indefinitely. But this is not the case : the sap normally ascends. What is the mechanism which maintains the unidirectioned flow ?

As previously stated, the rise of sap has been held to be due to the action of a pull exerted by the transpiring leaves from above and a push from below by the root. The fact that the sap-movement is not essentially dependent on the terminal organs has already been demonstrated qualitatively (Experiment 205). I now describe other experiments which give quantitative results. The rate of movement of the sap and the variations induced in it were ascertained by observation of the varying rate of suction of water at the cut end of the stem by means of the apparatus described below.

THE POTOGRAPH

This apparatus consists of a capillary potometric tube with a contrivance for recording the excursions of a water-index and its time-relations. The record may be most simply taken by following the water-index with a recording-pen resting on a revolving drum, round which is wound the paper for the record (fig. 216). It is sufficient for many

purposes, to determine the normal rate and the change of that rate by noting the number of divisions through which the water-index moves in the course of a minute in a definite part of the capillary tube of the potometer. The index can readily be brought to any particular point of the capillary tube by proper manipulation of the stopcocks S or S'; slight opening of S makes the index move to the left, that of S' to the right. The absolute rate of suction in cubic mm. is found by multiplying the length of excursion of the index per unit of time by the capillary constant of the tube.

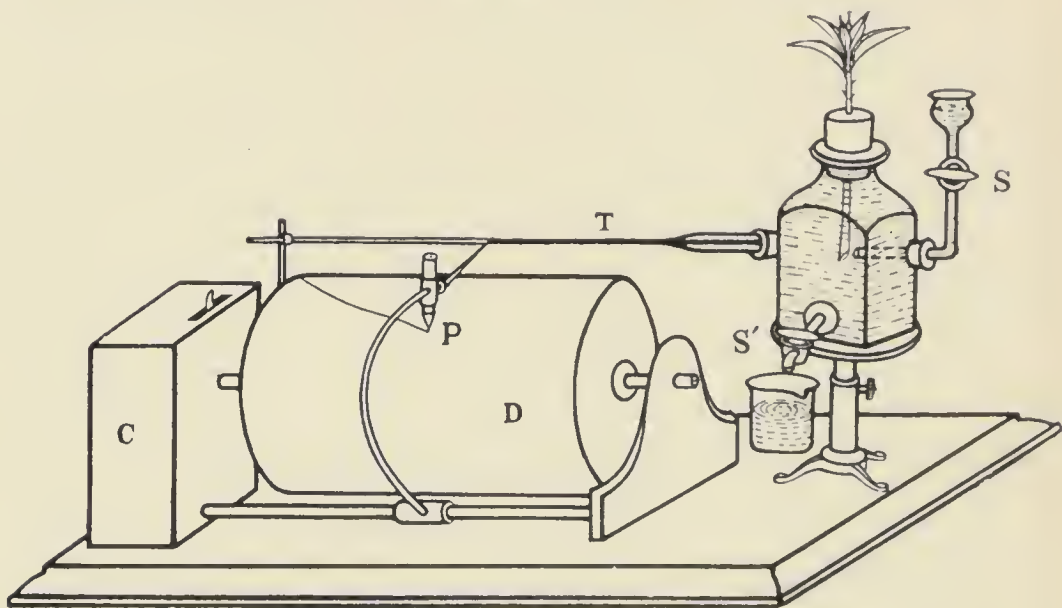

FIG. 216. The Potograph. (See text.)

Special care has to be taken to prevent all leakage, by smearing the indiarubber cork holding the plant with cocoa-butter. For ordinary experiments in which the effect of variation of temperature is not important, the temperature of the vessel does not, in practice, vary from that of the room. But in investigating the physiological effect of variation of temperature, complications arise from the gain or loss of heat by the water in the vessel. This is reduced to a minimum by enclosing the plant-vessel in a non-conducting cover of thick felt. It is also easy to construct a correction-curve for the particular apparatus. The error introduced in neglecting this correction is, however, less than 2 per cent.

Variation in the normal rate of suction can be induced by stimulating either the upper or the lower end of the specimen. The subject will be considered in greater detail in the next chapter.

ROOT NOT ESSENTIAL FOR ASCENT OF SAP

The fact already stated that the ascent of sap takes place in Palms in which there is practically no root-pressure, suggests that the co-operation of the root is not essential. This is definitely proved by the results of the following experiments which show that the rate of ascent, instead of being lowered, is considerably enhanced after the removal of the root.

Experiment 213.—The rate of suction and of ascent of sap in an intact specimen of *Helianthus*, measured by the movement of the index in the potometer, was 15·8 mm., the quantity of water sucked up for every minute being 22·1 cubic mm. The root was then cut off, and the stem replaced in the potometer. After a suitable period of rest, the amount absorbed by suction per minute was found to have increased to 40 cubic mm., an enhancement of 1·9 times. The root, on the root-pressure of which the propulsion of sap is supposed to depend, so far from increasing the rate of ascent, had actually impeded the flow of sap. In another experiment, with *Impatiens*, the rate of suction of the intact plant was more than doubled after removal of the root. *The root instead of helping the ascent actually retarded it.*

The following considerations explain the unexpected result. The rate of flow of the sap depends directly on the pumping activity and inversely on the resistance offered by the channel for the transport of water. In a plant with roots, the attenuated channels of the root-hairs offer great resistance to the inflow ; whereas in the case of a cut shoot the resistance offered by the absorbent cut surface of the stem is considerably less.

ASCENT OF SAP IN ABSENCE OF ROOT AND LEAF

The ascent of the sap has been shown to occur when the plant is deprived of its roots; nor is the sap-movement entirely dependent on the pull exerted by the transpiring leaves. It can be shown that the movement of sap takes place even in a piece of bare stem, from which both the roots and leaves have been removed. The specimen is taken in the condition of drought, and the bare stem is coated with an impermeable varnish. After making a fresh cut at the lower end, the specimen is mounted suitably on the Potograph, and the rate of suction measured for every successive minute during a period of 80 minutes. The results show that even in the total absence of transpiration the ascent of sap persisted for a considerable length of time.

Experiment 214.—This was carried out with two different species of plants, *Centaurea* and *Impatiens*; the activity of *Centaurea* is about 10 times greater than that of *Impatiens*. The results are given in the following table:

TABLE XX.—GIVING RATES OF SUCTION IN VARNISHED BARE STEMS OF *CENTAUREA* AND *IMPATIENS*.

Time intervals after commencement	Rate of suction (cubic mm. per minute)	
	<i>Centaurea</i>	<i>Impatiens</i>
Immediately after	18·0	2·0
1 minute after	24·0	2·3
2 minutes ..	31·0	2·6
3	36·0	3·0
4	36·0	3·35
5	32·0	3·48
6	27·0	3·50
11	15·4	3·30
16	7·2	2·60
21	3·3	2·19
26	2·0	1·80
31	1·7	1·53
60	0·9	0·45
65	0·7	0·33
70	0·51	0·25
75	0·45	0·17
80	0·25	0·80

The results show that the rate of ascent at first increases, then attains a climax, after which it undergoes diminution (fig. 217).

The question arises: By what mechanism is the sap transported upwards in a bare stem with one end immersed

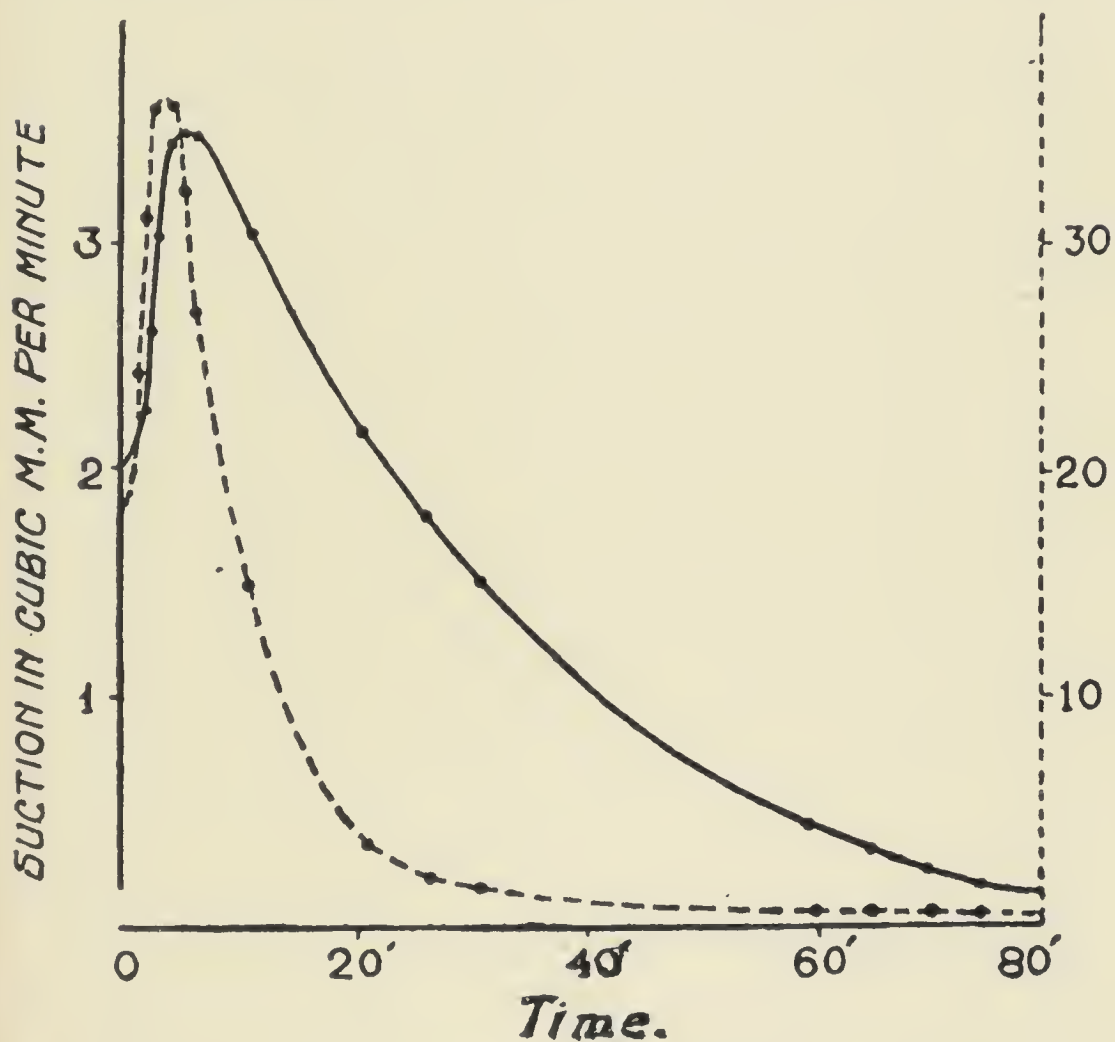

FIG. 217. Curves showing rates of suction in varnished stems of *Centaurea* (dotted curve) and *Impatiens* (continuous curve).

Note increase of rate followed by diminution.

in water, though there is no push from below attributable to root-pressure, nor any pull from above by transpiring leaves? It is also necessary to explain why, in the above experiments, the rate of ascent underwent subsequent diminution.

In explanation of the remarkable results described above, it is necessary to bear in mind certain universal characteristics of rhythmic tissues which have been demonstrated in the previous chapters. It has been shown that the arrested pulsation of the heart is revived by increased internal pressure (p. 256), and that the pulsation of the stomach is revived by distension (p. 289). In *Desmodium* also, the pulsatory activity brought to a standstill under drought was revived by turgor-distension caused by irrigation (p. 255).

In regard to the increase of rate of ascent observed at the beginning of Experiment 214, the pulsatory activity of every section of the stem was in a state of arrest due to drought. The absorption of water at the lower end renewed the activity at that point, and gradually that of others higher up as the liquid pumped up reached them. In process of time a large number of cellular pumps became activated with resulting increase in the rate of ascent. Thus in *Centaurea* the suctional rate of 18 at the beginning increased to 27 in the course of 4 minutes ; and in *Impatiens* likewise, the initial rate, which was 2, became enhanced to 3.5 after 6 minutes.

The question why the rate of ascent after attaining a climax should undergo a continuous diminution has next to be considered. The answer is to be found in the law guiding the direction of propulsion of peristaltic waves already established (p. 292). It was there shown that *the direction of propulsion is from the more to the less activated end of the organ*. In the present case the lower end of the stem was activated by turgor-distension caused by irrigation ; hence the unidirectional flow was from the hydrostatically tense and activated lower end to the less turgid upper end, still in a state of drought. But the upper end soon becomes turgid and distended by the accession of water pumped up from below. The differential activity which determines the rate of flow undergoes, after a while, a diminution. The resultant flow thus tends to disappear when the two ends become equally turgid and active (*see* fig. 217).

RÔLE OF TRANSPIRATION IN THE UNIDIRECTIONED
PROPULSION OF SAP

The important rôle of transpiration in directing the flow of sap upwards in the plant will now be briefly considered. When the shoot and the root of the plant are equally turgid the activities at the two ends balance each other, rendering any ascent of sap impossible. The transpiring leaves do not raise water by exerting a sucking force as such, but transpiration ensures differential activity by causing incipient drought in the transpiring region. The turgor-tension gradient extends from the root to the apex of the stem; it is the differential physiological activity induced at the two ends that drives the sap upwards against the force of gravity. There is a limit to the height of water which can be raised by physical forces; but there is no such limit in the case of physiological action.

Experiment 214a. *Propulsion of sap in the midrib in absence of root-pressure and of transpiration.*—Though the fact that the ascent of sap can be observed in a bare stem is sufficient by itself to invalidate the assumption that root-pressure and suction by the transpiring leaves are essential for it, yet the evidence of the following experiment with a leaflet of Lupin is of confirmatory value.

A single leaflet, drooping from drought, had a portion of its lamina removed so as to leave a short piece of the midrib projecting at the lower end. After being coated with vaseline, it was mounted in the cork of a small bottle. Some warm dilute camphor-water was poured into the bottle through another hole in the cork, until it just reached the freshly cut end of the midrib in the bottle. The wilted leaflet now rapidly reared itself up, becoming turgid, and was erect in 4 minutes. It was noticed in the course of 15 minutes that drops of liquid exuded, under the coating of vaseline, along each side of the midrib on the lower surface.

It is clear that in this experiment water was absorbed in the absence of transpiration, for the leaflet was rendered impervious by vaseline, and of course of root-pressure. The transport of absorbed water can only have been effected by the propulsive activity inherent in the midrib, this activity being heightened by the stimulating action of camphor. Moreover, in the absence of any loss of water by transpiration, the turgidity of the midrib became so excessive that water was forced out of it under pressure.

NORMAL AND REVERSED PERISTALTIC WAVES

It may naturally be asked, Does the peristaltic wave always move the sap upwards? Would it be possible to reverse the direction of the peristaltic wave, so as to cause the sap to flow downwards? The possibility of this has already been demonstrated in Experiment 205. The two cut ends of a specimen under drought were successively touched with water, and the passage of antiperistaltic and peristaltic waves detected by means of the Sphygmograph. The effectiveness of the peristaltic wave was found to be far more intense than that of the antiperistaltic.

Experiment 215.—Reversal can be demonstrated by even simpler methods. For instance, when water is withheld from a potted plant, the stem bends over under the drought, and the drooping leaves hang down. If a glass of water be then raised so that the apical end of the drooping stem is immersed in it, the upper part of the stem will absorb water and become more turgid than its lower end. The pulsating activity becomes revived at the upper end; the gradient of turgor-tension is reversed and the sap now flows downwards, that is, against the direction of normal ascent. The reversed flow is demonstrated by the sequence of revival of the drooping leaves, which takes place from the tip of the stem backwards.

The following method demonstrates peristaltic and antiperistaltic propagation in a striking manner.

Experiment 216.—Two similar bare stems of *Impatiens*, with all leaves removed, were taken in a condition of drought. The flaccid stem bent over from the point of support. An equal length of bare stem was taken in each case, of which the apical end will be distinguished as A, and the basal end as B. The cut preparations were suitably supported by a clamp, just behind the bend. In *a* a piece

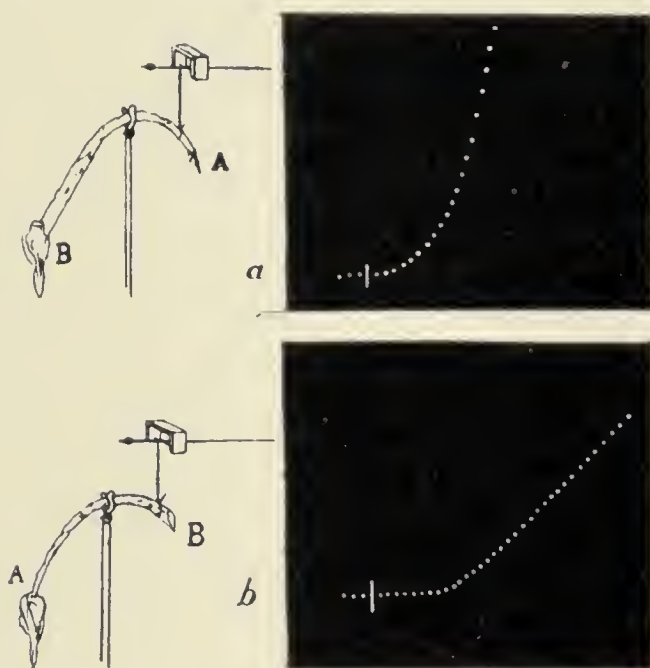

FIG. 218. Curves showing (*a*) the effect on transport of sap in a stem under drought when water was applied to the basal end B, and (*b*) the effect in a similar specimen under identical conditions when water was applied to the apical end A (*Impatiens*).

of cotton was attached to the lower cut end B for the application of water, and in *b* a similar arrangement was made for application of water at the upper end A. Application of water at the basal end B caused an erectile response of the apical end attached to the recording-lever. The distance between B, the point of application of water, and the responding point just beyond the support, was 35 mm. The record (fig. 218, *a*) is essentially similar to that of an intact plant with leaves, though the response was manifested by the movement of the drooping stem in the one case and by the

movement of the drooping leaf in the other. The successive dots are at intervals of 20 seconds, and the erectile response occurred after the second dot.

Application of water at the apical end A produced an erectile response of the lower end of the stem, due to transport of sap in a direction opposite to the normal, *i.e.* from apex to base. The distance of transmission was the same as in the last case, but the response occurred after 8 dots (fig. 218, *b*), instead of 2. The velocity of transport of sap in the reverse direction is thus found to be at least 4 times slower; this slower rate is also demonstrated by the more inclined slope of the curve. Other experiments showed that the transmission in the reverse or unusual direction is from 4 to 6 times slower than in the normal direction.

The results described tend to show that the membrane of each individual cellular pump acts as a valve which allows easier passage in the normal direction, preventing, to a certain extent, the backward flow.

It is interesting to note that the peristaltic contractile wave of the heart, as also that of the stomach, can be reversed; it has been further shown that the propagation of the wave in the reverse direction is considerably slower than in the normal direction (*see* p. 289).

The results of the foregoing experiments prove conclusively (1) *that the movement of sap is not determined solely by the terminal organs, leaf and root; (2) that there is a propulsive activity in the stem, in the petiole, and in the midrib of the leaf; and (3) that the direction of the flow of sap is not necessarily upwards, but can be inverted downwards by reversing the differential activity at the two ends of the organ.*

SUMMARY

The root is not essential for the ascent of sap. This is proved by experiments carried out with the Potograph showing that the rate of ascent was nearly doubled after the

removal of the root. This is explained by the fact that in a plant with roots the attenuated channels of the root-hairs offer great resistance to the inflow ; whereas in a cut shoot, the resistance offered by the surface of the cut end of the stem is considerably less.

The fact that the leaf is not essential is proved by the rise of sap in a leafless stem in a state of drought, the lower end of which is placed in water. The rate of ascent increases at first and then undergoes a diminution.

It is explained that the flow of sap depends on differential activity at the two ends of the organ. The turgid end is more active than the other end still in a state of drought. The resultant unidirectional flow tends to disappear as the two ends become equally turgid.

Application of stimulating solution of camphor to the lower end of the midrib of a drooping leaflet of Lupin coated with vaseline not only caused a rapid erection of the leaflet, but also exudation of water under pressure.

The direction of flow of sap is not necessarily ascending ; it can be reversed by reversing the gradient of turgor-tension. The effectiveness of the peristaltic wave moving upwards is about 4 to 6 times greater than that of the antiperistaltic wave moving downwards. The membrane of each individual cellular pump seems to act as a valve which allows easier passage in the normal direction, preventing, to a certain extent, the backward flow.

CHAPTER XXVI

THE RESPONSIVE MOVEMENT OF SAP UNDER DIFFERENTIAL STIMULATION

THE fundamental factor in the propulsion of sap has now been traced to the pulsating layer in the cortex, which is continuous throughout the plant. By eliminating the complicating factors of the action of roots and leaves, the functional importance of this propulsive tissue has been demonstrated. The electric pulsation of the propulsive tissue in every section of the stem proves the continuity of the cellular pumps, the co-ordinated activities of which propel the sap in a definite direction. It has also been shown that the propulsive mechanism in the plant is essentially peristaltic as it is in the animal. The peristaltic wave in the animal has been proved to follow the stimulation-gradient, under the different modes of stimulation employed for this purpose :

- (1) Mechanical distension.
- (2) Thermal stimulation.
- (3) Chemical stimulation.
- (4) Electric stimulation.

The production of peristaltic and antiperistaltic waves in the plant by differential turgor-tension at the two ends, has already been demonstrated in the previous chapter. In the present chapter I describe in detail the effect of thermal stimulation, reserving the effects induced by chemical and electric stimulation for subsequent chapters. The demonstration will be rendered more rigorous by increasing elimination of all but the essential factors.

The physiological activity at the two ends of an isolated

stem has been shown to be practically the same when they are equally turgid. In such a case there is no perceptible flow of sap. The cessation of sap-movement here is not due to lack of activity, but to full activities balancing each other.

I attempted to upset this balance by inducing an enhancement or a depression at one end or the other of the stem. The subject was investigated by the Potographic Method in the following order :

- (1) The effect of stimulation or depression of the upper end of the stem ;
- (2) The effect of stimulation or depression of the lower end ; and
- (3) Combined effect of stimulation of both the upper and the lower end.

A piece of stem, after removal of leaves, is mounted with its lower end immersed in the water of the Potograph ; a hollow cork with a hole at one side is fitted on the upper cut end of the stem for the application of water at the upper end without its exerting any pressure (*see fig. 219, a*). To secure this, the hole drilled on one side of the cork is 3 mm. above the surface of the stem, thus allowing overflow of any excess. The balanced condition of turgor is, after a while, practically, though not absolutely, perfect. A *residual flow*, usually in the direction of ascent, persists, but it is so feeble as to be practically negligible. For quantitative measurements, a correction has, however, to be applied for this residual current. The following result obtained with *Helianthus* gives an idea of the residual effect in the bare stem in the balanced condition, as compared with the normal rate of suction of the cut stem before removal of the leaves. The normal rate of suction of the cut stem with leaves was + 9 cubic mm. per minute, the plus sign indicating the movement of ascent. After removal of the leaves, and approximate balance by application of water at both the lower and upper ends, the residual current was -| 0.2 cubic mm. in the direction of ascent.

An enhancement or a depression of activity at either the upper or the lower end of the stem was produced by thermal means, the resulting upset of the balance being observed by the responsive movement of the water-index. A rise of temperature, within limits, has been shown to enhance the activity, while cooling causes a depression. The upper end of the stem A may thus be stimulated or depressed by application of warm or of cold water. Similarly, stimulation or depression of the lower end can be produced by projecting a stream of warm or cold water against the lower end B (*see* fig. 219, a). Observation of the movement of the water-index is made only after the attainment of steady propulsion of sap under the new condition. The increased rate of ascent of the sap is indicated by the quicker movement of the water-index to the right. Reversed movement of sap downwards and expulsion at the lower end is indicated by the movement of the water-index to the left (*see* fig. 219).

EFFECT OF THERMAL STIMULATION OF UPPER END

Experiment 217. *Thermal stimulation of upper end of stem of Helianthus.*—The results are given in the following order: (1) the residual flow under condition of approximate balance after application of water to both lower and upper ends; (2) effect of stimulation of the upper end by warm water. The resultant responsive variation under differential stimulation of the two ends is then calculated from (2) and (1). The number given represents the movement of the index in mm. per minute. Plus sign or up-pointing arrow represents ascent of sap in the stem; minus sign or down-pointing arrow indicates the reverse flow from the upper end A towards the lower end B.

Residual flow	+ 0·57
Effect of enhanced activity of upper end A on application of warm water	— 5·40
Responsive variation	— 5·97 ↓

The enhanced activity induced at the upper end by local application of heat produces a responsive movement of sap downwards from the activated A to the indifferent and less active B.

In *Helianthus* the rates of the normal movement of sap and of its induced variations are comparatively feeble. Far more striking results were obtained with the more active plants, *Antirrhinum* and *Cosmos*.

Experiment 218. *Thermal stimulation of upper end of Antirrhinum.*—In order to avoid useless repetition I give only the responsive variation induced in the rate of movement of sap.

Responsive variation — 64·0 ↓

Here also thermal stimulation of the upper end caused a reversal of the normal rise of sap into a reversed down-movement. *Cosmos* gave very similar results.

EFFECT OF DEPRESSION OF UPPER END INDUCED BY COLD

Experiment 219.—The application of cold to the upper end induced an effect precisely opposite to the stimulatory action of heat, though relatively less intense. Of the results of two experiments given below, one was obtained with the less active *Helianthus* and the other with the more active *Cosmos*.

Responsive variation :

<i>Helianthus</i>	+ 2·9	↑
<i>Cosmos</i>	+ 9·3	↑

Depressed activity of the upper end thus induced an up-movement of sap from the relatively more active lower end B towards the depressed upper end A.

I next describe the effects of variation of activity induced at the lower end.

EFFECTS OF STIMULATION AND DEPRESSION OF
LOWER END

The temperature at the lower end B can be raised or lowered by projecting a small quantity of warm or cold water against it, on opening the stopcock of the funnel F containing water at the required temperature (*cf.* fig. 216). After allowing a short time for the attainment of a steady rate of movement of sap, the index is brought to the middle, and the rate of suction measured in the usual manner. The two following experiments were carried out with *Helianthus*.

Experiment 220. *Effect of heat at lower end :*

Responsive variation + 7.7 ↑

The enhanced activity of the lower end B produced by heat induced an upward movement of sap from the activated B to the less active A, causing an enhancement of the rate of ascent.

Experiment 221. *Effect of cold at lower end :*

Responsive variation - 4.5 ↓

The effect of the depressed activity due to application of cold to the lower end B was a down-movement from the relatively more active upper A to the less active lower end B.

COMBINED EFFECTS

After ascertaining the respective effects of induced variations of activity at the two ends, I sought to determine their combined effects. The results of experiments showed that the individual effects became summated under depressed activity of the upper and enhanced activity of the lower end and *vice versa*.

Experiment 222. *Rate of ascent induced in a bare stem under differential stimulation (Helianthus).*—On application of water at the upper end, balance was produced, the residual flow being practically zero. Differential activity at the two ends of the stem was now induced by application of cold water above and warm water below, with the following results.

Responsive variation, under stimulation of lower and depression of upper end = $+ 10.9$.

In the next experiment warm water was applied above and cold water below. The result was a marked reversal of sap-movement downwards.

The rate of movement in all cases is determined by the *differential activity* at the two ends, the flow being directed from the more to the less active end.

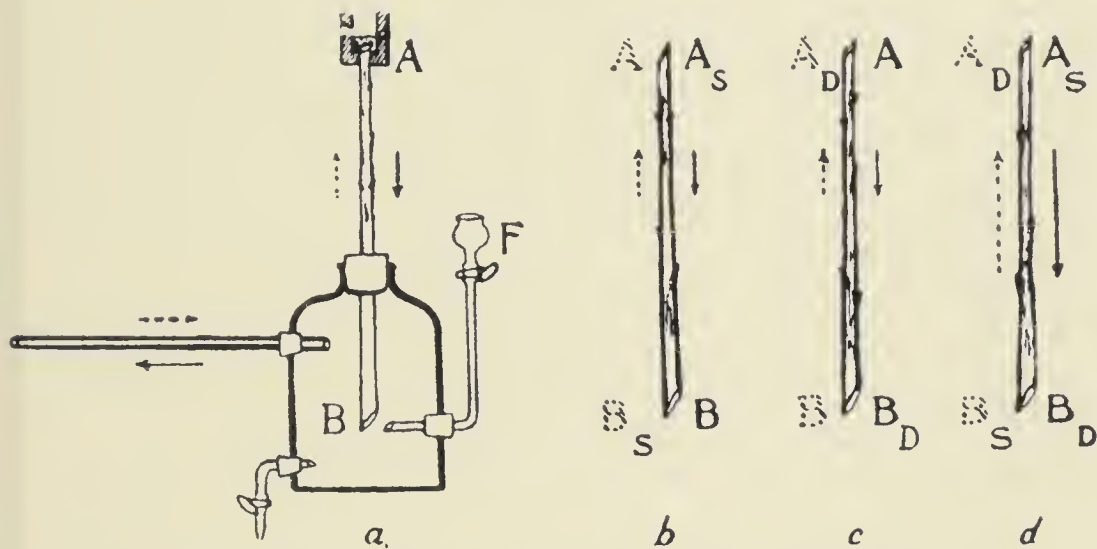

FIG. 219. Diagrammatic representation of the Potograph and of the effects induced by stimulation or depression of the two ends of the stem.

Direction of flow of sap from the more stimulated to the less stimulated or depressed region.

a, the Potograph. *b*, effects of alternate stimulation of the upper end A_S and the lower end B_S . A_S induces flow of sap downwards (full arrow); B_S causes flow of sap upwards (dotted arrow). *c*, effects of alternate depression of the lower end B_D and of the upper end A_D . B_D induces flow of sap downwards (full arrow); A_D , flow of sap upwards (dotted arrow). *d*, additive effect of simultaneous stimulation of one end of the stem, and depression of the other. Enhanced flow downwards (longer full arrow) under $A_S B_D$, and upwards (longer dotted arrow) under $B_S A_D$.

COMPARISON OF RATE OF ASCENT IN INTACT PLANT AND IN ISOLATED STEM

I was next desirous of obtaining some approximate idea of the normal rate of ascent of sap in the intact plant with root and leaves, and the rate induced in the bare stem by

differential stimulation by cold above and heat below. The experiments, it should be noted, were carried out with an identical plant.

Experiment 223. *Determination of rate of ascent in intact plant.*—The rate of ascent of sap in a shoot of *Helianthus* without roots was found to be $+7.2$. The presence of roots has been shown (p. 339) to reduce the rate of ascent to nearly half. Hence in the particular specimen the rate of ascent in *Helianthus* in intact condition may be estimated as $+3.6$ approximately.

The leaves on the shoot were then removed, and the two ends of the bare stem subjected to differential stimulation. The result is given in Experiment 222, the rate of ascent of sap being $+10.9$ in the place of $+3.6$ of the identical plant with root and leaves. In other words, *by inducing differential activity of the two ends of the bare stem, the rate of propulsion became three times more active.* The leaves and roots in the intact plant evidently do not exploit the full potentiality of the propulsive mechanism.

The various results of separate and combined effects are diagrammatically shown in fig. 219, in which *a* is the Poto-graph with the bare stem. The responsive movement of ascent is indicated by the dotted, and the reverse down-movement by the continuous arrow. The separate effects are shown in *b* and *c*, and the combined effects in *d*. In all cases the down-movement of sap, due either to stimulation of A or depression of B, or by simultaneous stimulation of A and depression of B, is indicated by a full arrow. The ascent of sap, on the other hand, is indicated by a dotted arrow, caused by stimulation of B or depression of A, or by simultaneous stimulation of B and depression of A, the letters in these cases being in dotted outline. To recapitulate: *b* shows the flow of sap downwards (full arrow) due to stimulation of the upper end, and the reversed flow of sap upwards (dotted arrow) by the

stimulation of the lower end ; *c* shows the flow of sap downwards (full arrow) by the depressed activity of the lower end, and the reversed flow upwards (dotted arrow) by the depressed activity of the upper end ; *d* shows the combined effects of enhanced activity of the upper and depressed activity of the lower end (longer full arrow) ; the combined effect of enhanced activity of the lower and the depressed activity of the upper end is indicated by the strong ascending current (longer dotted arrow).

THE BUBBLE-METHOD

I now describe an additional and very sensitive method for investigating change in the direction of flow of the sap induced by differential activity of the two ends of a bare petiole or stem. The following experiment was carried out with the petiole of *Hibiscus mutabilis*. A complete hydraulic circuit was made of the petiole and a capillary glass tube, the two being connected by indiarubber tubes, all the tubes filled with water, with the exception of an air-bubble in the middle of the capillary tube. The bubble is adjusted as follows : one end of the tube is immersed in a large vessel of water, and the other end is lowered gradually. This drives out the air and fills the tube with water ; in order to trap a bubble of air, one end is raised slightly above the water and afterwards closed with the finger. The enclosed bubble is then brought to the middle by placing the tube horizontal under water and removing the finger : the bubble is adjusted to any position in the capillary tube by a slight tilt in one direction or the other. The tube is connected under water to the ends of the petiole by means of short lengths of indiarubber tube. The preparation is now taken out of the water and permanently mounted on the table for experimental observation. The activities of the two ends of the petiole in contact with the water in the indiarubber tube are nearly, though not exactly, the same. There is a residual

flow (say from the basal end B on the right to the apical end A on the left) on account of slight difference in the activity of the two ends. In order to induce differential action, semi-cylindrical hollow containers of cork are fitted to the two ends of the petiole, these being alternately heated or cooled by means of warm or ice-cold water. The resulting movement of sap per minute is measured by observing the excursion of the bubble by means of an eye-piece provided with a micrometer (fig. 220).

The normal movement of ascent, denoted by a plus sign, is from the basal end B to the apical end A. In the bare

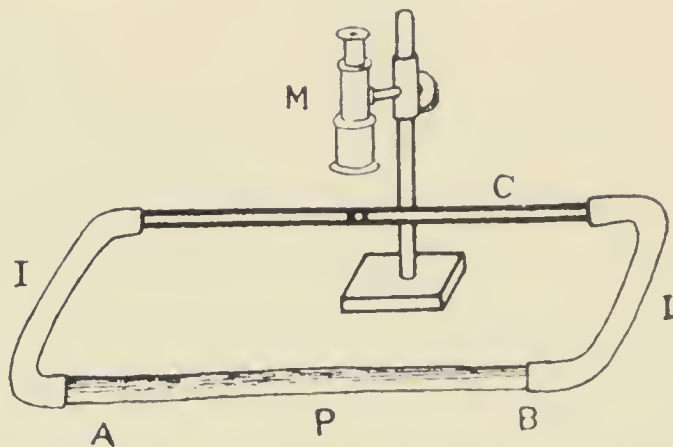

FIG. 220. Directive flow of sap under differential stimulation at basal end B and apical end A of the petiole.

P, plant; I I, indiarubber tubes; C, capillary glass tube; M, micrometer eye-piece for reading movement of air-bubble enclosed in the capillary tube.

petiole the sap-movement was practically zero when water at the same temperature was applied at the two ends.

Experiment 224. *Effect of enhanced activity of basal end B, and of depressed activity of apical end A (Hibiscus).*—The basal end B was stimulated by application of heat, and the apical end A depressed by application of cold.

Responsive flow B to A = + 24 divisions per minute (enhanced flow upwards).

Experiment 225. *Reversal of direction of flow by stimulation of apical end A and depression of basal end B.*—The differential activity of the two ends was reversed by

application of heat to the apical end A, and of cold to the basal end B.

Responsive flow A to B = — 10 divisions per minute (flow of sap reversed downwards).

Experiments carried out with the more active Antirrhinum and Cosmos gave even more striking results. In all cases the resulting movement of sap was from the more to the less active or depressed end.

LAW OF DIRECTIVE FLOW OF SAP

The results given establish the following :

- (1) BALANCE EXISTS WHEN THE TWO ENDS OF THE ORGAN ARE EQUALLY ACTIVE.
- (2) DIFFERENTIAL ACTIVITY INDUCED AT THE TWO ENDS OF THE ORGAN GIVES RISE TO A RESPONSIVE FLOW, THE DIRECTION OF WHICH IS FROM THE MORE TO THE LESS ACTIVE REGION.

Effects essentially similar were observed in the propagation of peristaltic waves in the heart and in the stomach of the animal (Chapter XXI).

SUMMARY

Irrigation of both ends of a bare cut stem produces equal turgor-tension at the two ends ; there is practically no flow of sap in the stem.

This state of balance is upset by unilateral stimulation or depression by the application of heat or cold respectively. The direction of flow of sap, either upward or downward, demonstrates the law that the responsive flow of sap is from the activated to the less active or depressed region.

As regards the fundamental mechanism of the movement of sap, the root or the leaves are by no means essential, nor

do they fully exploit the potentiality of the physiological mechanism for propulsion. This was demonstrated in a striking manner by an experiment in which, by means of differential stimulation, the rate of ascent in a bare stem was enhanced three times beyond that in the intact plant.

An identical law governs the passage of the contractile peristaltic wave in both the animal and the plant.

CHAPTER XXVII

MECHANICAL RECORD OF CELLULAR PULSATION

RESULTS obtained with the Electric Probe, described in a previous chapter, demonstrated the occurrence of electric pulsation indicating the pulsation of the active cells in the propulsive layer. I next attempted to obtain the direct mechanical record of the infinitesimal contractions and dilatations associated with the peristaltic transmission of sap by this layer. It is possible to induce changes in the blood-pressure by various means which modify the pumping activity of the animal heart. Is it possible to induce parallel changes in the sap-pressure by similar means?

THE OPTICAL SPHYGMOGRAPH

For such an investigation, the sensitiveness of the High Magnification Sphygmograph, already described, proved to be quite inadequate. It was therefore necessary to devise an apparatus which should possess the following advantages:

- (1) The movement of dilatation and contraction of the channel conveying the sap by peristalsis, should be greatly magnified so as to be rendered visible to a large audience.
- (2) The period of experiment should be reduced so as to exhibit all important reactions in the course of a few minutes, during which the external conditions could be maintained constant.
- (3) The inertia of the indicator should be practically negligible.

The Optical Sphygmograph perfectly fulfils all these conditions. The movement of the primary lever *L* of the Sphygmograph indicating dilatation or contraction of the cortical cells, which has already been described (*cf.* fig. 199), is further magnified by reflection from a small concave mirror carried by a vertical rod 0.5 mm. in diameter, supported

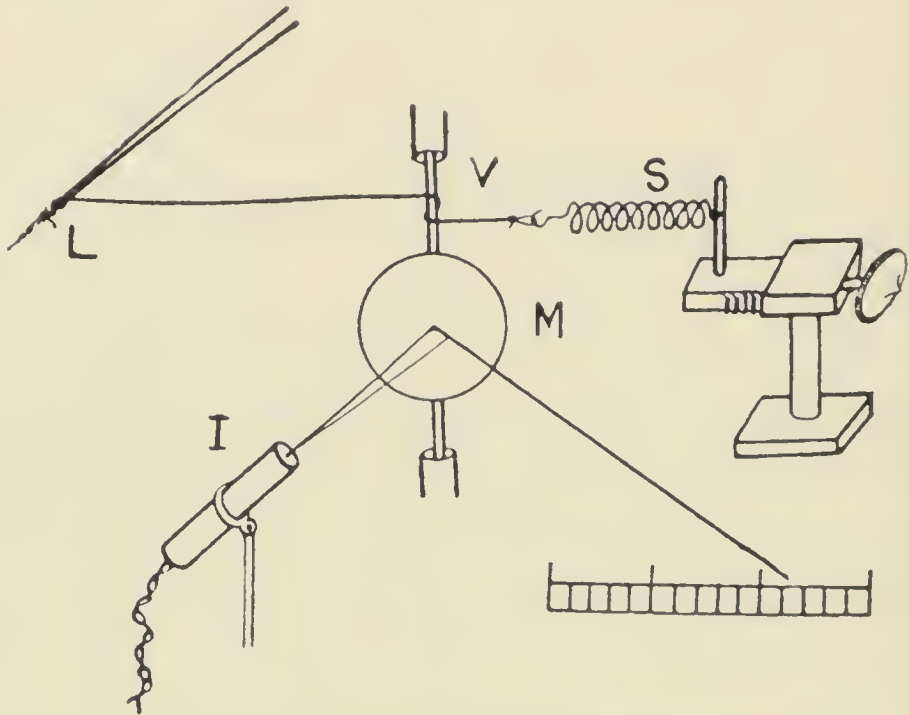

FIG. 221. Diagram of Optical Sphygmograph.

Silk thread tied to end of sphygmographic lever *L* goes round vertical rod *v* supported on jewel bearings and attached to spiral spring *s*; *m*, mirror attached to vertical rod. Responsive rotation is magnified by light reflected from mirror *m* on scale at a distance; *i*, electric lamp-holder.

both above and below on jewel bearings. A thin silk thread, tied to the tip of sphygmographic lever *L*, makes one turn round the vertical rod, the further end being attached to a fine spiral spring by which the pressure of contact can be adjusted (fig. 221).

Dilatation at the contact-point on the stem by the passage of an hydraulic wave causes a movement of the tip of the lever outwards, producing clock-wise rotation of the mirror and a positive movement of the reflected line of light, say

to the right. Contraction at the contact-point gives rise, on the other hand, to a movement of the light to the left. The mirror-rod, as already stated, is supported above and below by two jewel bearings, and its rotation can only be produced by cellular expansion and contraction causing a pull on or release of the thread. The grip of the thread on the vertical rod, and its support both above and below, render the indications of the Optical Sphygmograph singularly free from all external disturbance. The incandescent filament

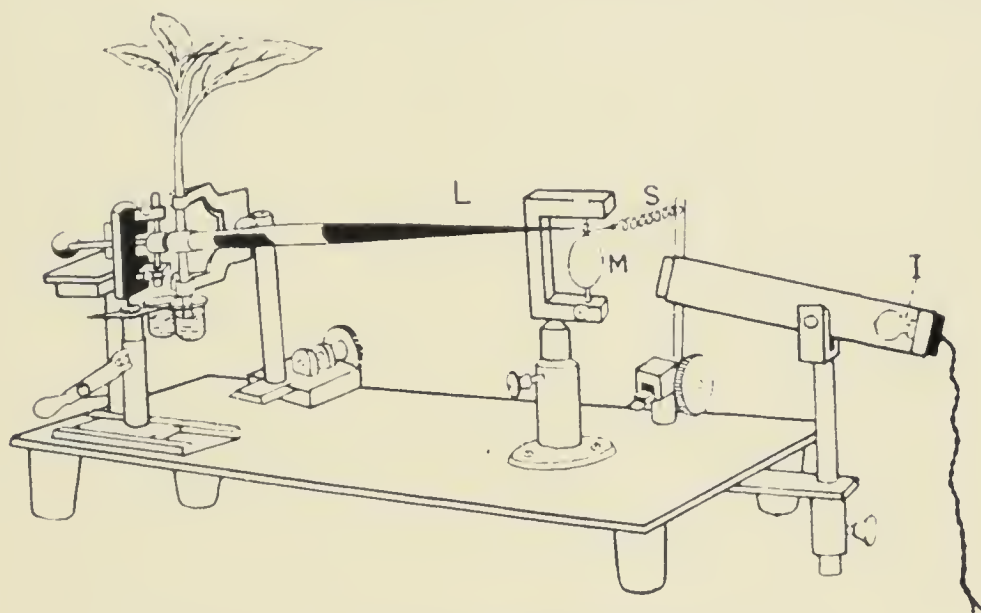

FIG. 222. The Complete Optical Sphygmograph.
(From a photograph.)

of a small pea-lamp can be so focussed by a lens carried by the lamp-holder that, after reflection from the mirror, a bright line of light is thrown on a distant scale or on a moving photographic plate. The complete apparatus is very compact and portable, as seen in the accompanying photograph reduced to one-half the natural size (fig. 222). The magnification produced is a million times when the scale is at a distance of 4 metres.

The apparatus is also provided with an Applicator which carries three small cups containing respectively a stimulating, a depressing, and a poisonous solution. One or other of these can be readily applied to the cut end of the stem.

EFFECT OF PRESSURE AT CONTACT

A satisfactory sphygmogram in man can be obtained only by means of suitable pressure on the radial artery. With too feeble a pressure there is no record, while excessive pressure arrests the pulse.

Experiment 226.—The sphygmogram of the plant also exhibits similar characteristics. The following table gives the responsive rates indicated by the movement of the line of light, as the pressure at the sphygmographic contact was increased from 0 to 7 units of an arbitrary scale.

TABLE XXI.—EFFECT OF INCREASING PRESSURE AT CONTACT
(CUT SHOOT OF CENTAUREA).

Pressure	Rate of responsive movement per 10 secs.
Slight	0 cm.
1 unit	9 "
2 units	22 "
3 "	105 "
4 "	32 "
5 "	7 "
6 "	5 "
7 "	0 "

I obtained similar results under increasing pressure measured in gramme. It was thus found that when the pressure was slight there was no response by the plant. Under a pressure of 0.7 gm. the rate was 60 cm. per 10 seconds, increasing to 100 cm. under 1.4 gm. This was the optimum pressure, for when it was increased to 3 gm. the rate was diminished to 32 cm. ; at 6 gm. it was further reduced to 12 cm. ; an arrest of response occurred when the pressure was increased to 12 gm.

The extreme sensitiveness of the Optical Sphygmograph, and its perfect reliability in physiological investigation, will be realised from the following account of an experiment in which the effects of diverse physiological variations were demonstrated in the course of time as short as 30 minutes.

OPTICAL DEMONSTRATION

Experiment 227. *Effect of physiological variation.*—A shoot of *Centaurea* in a state of drought was suitably mounted and a fresh cut made at the lower end. Water at different temperatures, and different chemical solutions, were applied one after another, each for 4 minutes, by which time the steady rate due to the physiological change was attained. The scale divided into centimetres was placed at a distance of 4 metres, the magnification being a million times. A small electric metronome struck a bell once in a second, and the excursion of the light index was observed for 10 seconds. After application of water at 21° C., the positive movement of dilatation was + 60 cm. per 10 seconds. Substitution of water at 6° lowered the rate to + 16; application of water at 34° raised the rate to + 150, or 2.5 times the rate at 21° C. Application of KNO₃ solution reversed the response from + 150 to - 28, showing that the withdrawal of sap from the responding cells was greater than the absorption. Reapplication of water at 21° C. restored the rate to + 56, which was practically the same rate as at the beginning. Poisonous solution of KCN caused a quick reversal of response to - 50. The power of response was found to be completely abolished after a time, for there was no recovery after fresh application of water. The results are summarised in the following table :

TABLE XXII.—RESPONSE TO PHYSIOLOGICAL VARIATION, BY OPTICAL SPHYGMOGRAPH (*CENTAUREA*).

Application of	Rate of magnified (+) movement of dilatation in cms. per 10 secs.	Rate of responsive contraction (-) in cms. per 10 secs.
Water at 21°	+ 60	...
" " 6°	+ 16	...
" " 31°	+ 150	...
KNO ₃ solution	...	- 28
Fresh water	+ 56	...
KCN solution	...	- 50
Fresh water	0	0

MECHANICAL RECORD OF PULSATION

I now pass on to consider the record of the actual pulse-wave in the propulsion of sap. The pulsations began to be perceptible under a magnification of a million times produced by focussing the light on the scale at a distance of 4 metres, the spot of light *appearing to move not continuously but by spurts, each spurt followed by a pause*. The focussed spot of light was, however, too broad to give a sharp photographic record. The necessary condition for a satisfactory record is a sharply focussed spot of light at a distance of 1 metre, giving a magnification of from 5 to 10 million times.

METHOD OF THE MAGNETIC SPHYGMOGRAPH

This high magnification was secured by the method of amplification previously employed in my Magnetic Crescograph and in my Magnetic Radiometer.¹ I used for this purpose a single magnetised lever in the place of the compound system of levers in the High Magnification Sphygmograph (*cf.* fig. 200). In front of the N-pole of the distant end of the magnetic lever is suspended a small magnetic needle with an attached mirror. As the N-end of the lever is raised by the pull of the sphygmographic lever caused by tissue-expansion, a very large deflection of the suspended needle is produced to the right, which is magnified by the reflexion of the line of light by the attached mirror. The sensitiveness of the apparatus is very greatly increased by the employment of a perfect system of astatic needles; by reducing the distance between the N-end of the magnetic lever and the suspended needle, the magnification can be increased from 5 to 10 million times.

In a balanced condition of turgor the average sap-pressure remains constant, as exhibited by the approximately horizontal part of the sphygmogram. This balance is,

¹ *Physiology of Photosynthesis*, p. 179.

however, not static but dynamic, the absorption of sap by the cells at the sphygmographic contact being equal to the expulsion. The alternating phases of rhythmic activity are exhibited by pulsatory variation of pressure, dilatation by an up-curve, and contraction by a down-curve. The amplitude of pulsation in the balanced condition is relatively slight, for any further dilatation of a cell already distended is a matter of some difficulty. The electric record of pulsation in the condition of balance (*see* fig. 213) offers no such drawback, for the electric response persists even under conditions which restrain any mechanical movement. The mechanical record of the feeble pulsation in the condition of balance is only rendered possible by the exceptionally high magnification of about 10 million times. The rhythmic expansion and contraction is exhibited in the pulse-records, expansion as an up-curve, contraction as a down-curve.

The mechanical pulsation, however, becomes very marked even under moderate magnification during variation of pressure, whether increase or diminution. It is then actually possible to follow the action of the cellular pump, and to note the unequal strokes delivered by it during enhancement or depression of the rate of ascent. The frequency of pulsation is found to be increased by physiological vigour of the tissue, by enhanced turgor, and by optimum temperature. Under favourable conditions the period of a single pulse may be as short as 5 seconds.

CHARACTERISTICS OF PULSATION DURING FALL AND RISE OF PRESSURE

The simplest and most certain way of inducing variation of sap-pressure is that of the alternate withdrawal and supply of water at the cut end of the shoot. The pumping activity, with its up- and down-strokes, is now exhibited in a very clear manner. In the first part of the record (fig. 223) the pressure was falling on account of brief with-

drawal of water, the diminution being indicated by a fall of the curve. The individual pulses during fall of pressure show that the down-stroke corresponding to the expulsion of sap from the active cells at the point of contact is larger than the up-stroke representing absorption. When water was applied at the cut end, the hydraulic wave reached the active cells at the contact-point in a short time. It is interesting to note the change in the character of the individual

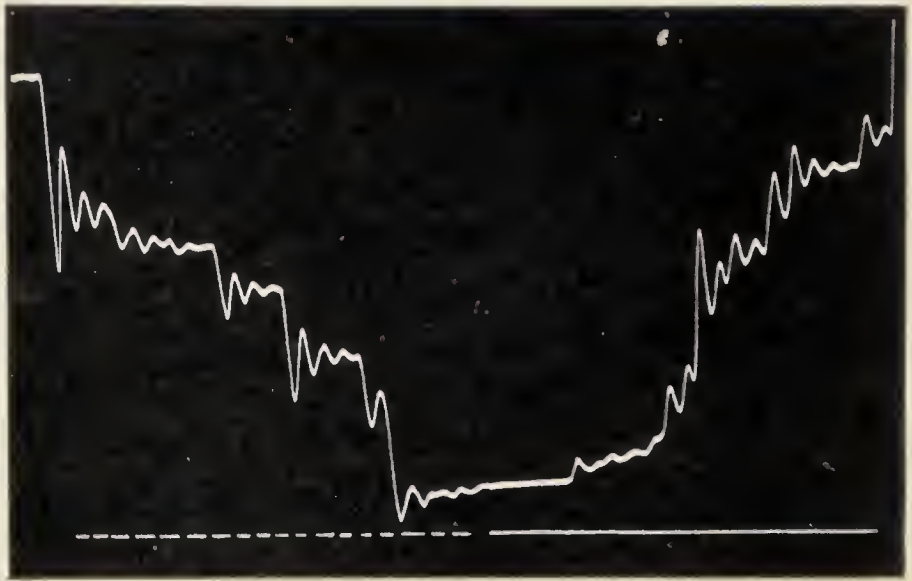

FIG. 223. Effect of alternate drought (dotted line below) and supply of water (continuous line below) on the pulsation of the active cells. The descending curve indicates a diminution, and the ascending curve an increase of pressure.

Note down-stroke of pulsation is the larger during diminishing pressure; during increasing pressure the up-stroke is the larger. Up-stroke represents tissue-expansion; down-stroke represents contraction (Cosmos).

pulsations by which the hitherto diminishing pressure was converted into one of increasing pressure. After a short period of hesitation the up-stroke became predominant; a series of such constituent pulsations produced the resultant increase of pressure indicated by an up-movement of the base-line of the record.

Other results will be described which establish the important generalisation that any agent which enhances the rate of ascent gives rise to an increase of sap-pressure, the

up-stroke of the constituent pulses being larger than the down-stroke. A depressing agent produces, on the other hand, a diminution of pressure, the down-stroke of the constituent pulses being now larger than the up-stroke.

Conversely the stimulating or the inhibitory nature of an agent can at once be discovered by its effect on the pulse-record. The sensitiveness of this method of detection is extraordinarily great. Taking for example the action of a stimulating agent, the immediate effect is a moderately large up-stroke followed by a feeble down-stroke ; the effect increases rapidly, so that the amplitude of the up-stroke becomes so great as to carry the record off the plate. The frequency of pulsation also increases to such an extent that the individual pulsations tend to merge one into the other

In studying the effect of stimulants on pulsation, I first applied agents which had been previously found to enhance the pumping activity of the ascent of sap. The high magnification employed introduced the difficulty that long-continued records cannot be taken within the limited size of a photographic plate. Hence the experiment had to be commenced with a balanced condition of turgor giving an initial record which is approximately horizontal. Enhanced rate of ascent of sap upsets the balance in an upward direction indicative of increased pressure. The method of observation under balanced condition is, as previously explained, less sensitive than that under the condition of incipient drought ; this drawback is, however, compensated by the exceptionally high magnification.

I now proceed to describe the effects of various agents on propulsive pulsation and sap-pressure.

EFFECT OF APPLICATION OF HEAT AT CUT END OF THE SHOOT

Experiment 228.—Balanced turgor was obtained after application of water at 18° ; warm water at 34° was then

substituted at H ; the balance is seen to have been upset in an upward direction indicative of increased pressure (fig. 224).



FIG. 224. Effect of application of warm water II in increasing sap-pressure in a shoot in the condition of balanced turgor.

The up-stroke of the constituent pulses became larger and larger, and the record soon went off the plate.

EFFECT OF LIGATURE ON PULSATION

The initial horizontal record had so far been obtained by inducing a condition of balanced turgor, and the characteristic effect of any external agent was manifested by the upsetting of the balance in either an upward or a downward direction. I next attempted to employ another method of obtaining balance, that of bringing the pulsation to a state of standstill. It occurred to me that as the pulsation of the heart can be arrested by a ligature, the same method might be effective in arresting the pulsation of the propulsive tissue in the plant.

Experiment 229.—Ligature below the sphygmographic contact was effected, without disturbing the record, by means of a screw-clamp. The first part of the record (fig. 225) shows the pulsation during active ascent of sap ; the application of the ligature at L arrested the pulsation and made the record horizontal.

The pulsation of the heart arrested by ligature can be revived by the application of external stimulation (*cf.* fig. 160). Similarly revival of arrested pulsation in the propulsive tissue of the shoot occurred under external stimulation. The results of moderately strong direct and of feeble indirect stimulation on the arrested activity of the plant are of great interest.

EFFECT OF DIRECT STIMULATION ON PULSATION
ARRESTED BY LIGATURE

Experiment 230.—The investigation was continued with the specimen in which pulsation had been arrested by ligature. A tetanising induction-shock was now sent along

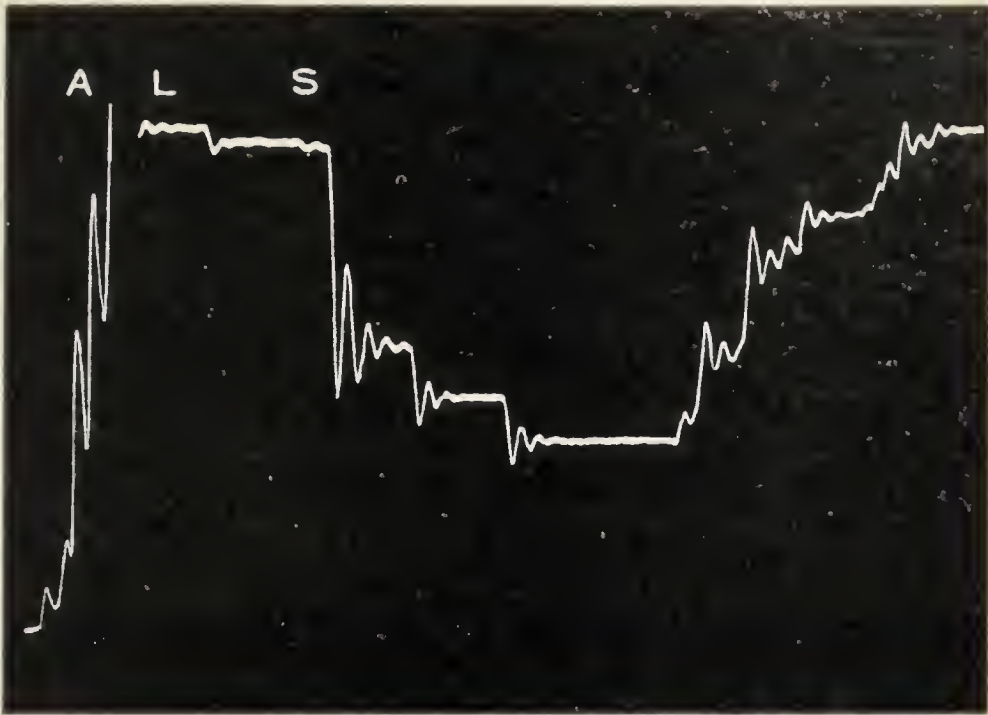

FIG. 225. Pulsation A became arrested by application of ligature at L.

Direct stimulation revived pulsation and caused diminution of pressure, the down-stroke being larger than the up-stroke; after cessation of stimulation, recovery of original pressure followed, the up-stroke being now larger than the down-stroke (Impatiens).

the length of the stem for 2 seconds. This gave rise, after a latent period of 5 seconds, to a diminution of sap-pressure, the pulse-record exhibiting a down-stroke larger than the up-stroke. After cessation of stimulation there was a recovery, the up-stroke during the process being larger than the down-stroke, till the original pressure was restored (second part of record, fig. 225).

EFFECT OF INDIRECT STIMULATION

For this purpose I removed the lamina from a lateral leaf of *Impatiens*, leaving only the midrib connected with the stem for the purpose of indirect stimulation. The object of the removal of the lamina was to eliminate the possible complication arising from varying rates of transpiration

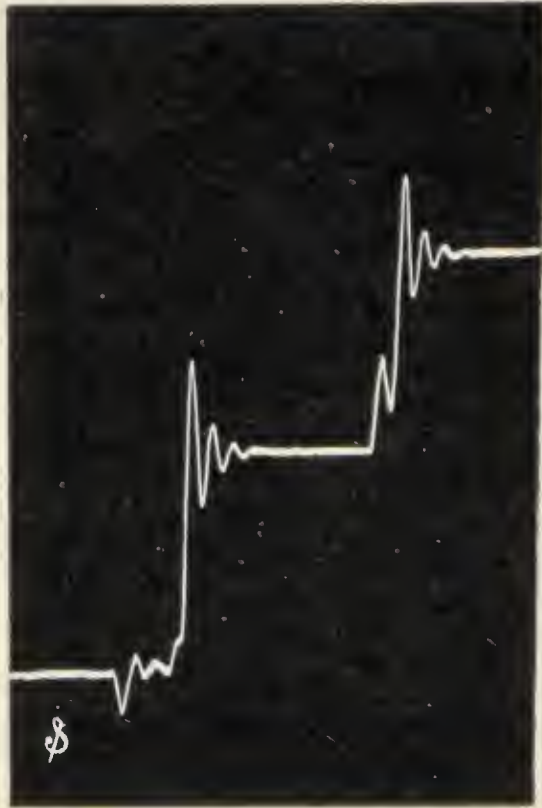

FIG. 226. Effect of feeble indirect stimulation in enhancing the sap-pressure (pulsatory up-curve) (*Impatiens*).

from its surface. The sphygmographic contact was 1 cm. above the lateral leaf, and the clamp was 1 cm. below it. The horizontal record at the commencement shows the effect of the ligature.

Experiment 231. *Effect of feeble electric stimulation on the midrib.*—Application of moderately feeble tetanising induction-shock at S caused a renewal of pulsatory activity resulting in an increase of pressure, the up-stroke being larger than the down-stroke (fig. 226).

Very strong indirect stimulation produces a diminution of pressure, an effect similar to that of direct stimulation.

SUMMARY

The alternate expansion and contraction of the cells active in the propulsion of sap have been recorded by the Magnetic Sphygmograph, which magnifies from 5 to 10 million times. The automatic records clearly exhibit the working of the cellular pumps ; any agent which enhances the pumping activity causes an increase of sap-pressure indicated by an ascending curve, the expansive up-stroke of the constituent pulsation being larger than the contractile down-stroke. Conversely, depressants diminish the pressure, as shown by a descending curve, the down-stroke of the individual beat being larger than the up-stroke.

Ligature produces arrest of cellular pulsation. The arrested pulsation can, however, be renewed by direct or indirect stimulation.

CHAPTER XXVIII

ACTION OF DRUGS ON PROPULSIVE PULSATION

I PROPOSE to study next the effects of various drugs on the propulsion of sap and on the circulation of the blood. The characteristic effect of a drug in enhancing or depressing the sap-pressure is manifest in the record given by the Optical Sphygmograph. In order to prove that the particular solution produces an identical action on the cardiac tissue, a parallel experiment was carried out with the animal heart. The stimulating character of a drug is demonstrated by enhanced frequency or increased amplitude of the heart-beat recorded by the Resonant Cardiograph, while the effect of a depressant is evidenced by the diminution of the amplitude or by the slowing down of the pulsation. For facility of comparison I will reproduce the characteristic cardiogram of the animal and the sphygmogram of the plant under the action of different drugs. These may, according to their action, be conveniently divided into three classes : (1) *stimulants*, which produce in general an enhancement of activity ; (2) *depressants*, causing an inhibition of activity ; and (3) *stimulant-depressants*, producing stimulation in minute doses and depression in moderately large doses.

For the detection of changes of activity in the animal heart, the Cardiograph is more direct and sensitive than the Sphygmograph. But the only apparatus which records the pulse-beat of the plant in the propulsion of sap is the Magnetic Sphygmograph. The similarity of effect of drugs on animal and plant may be tabulated as follows :

TABLE XXIII.—PARALLEL EFFECTS EXHIBITED BY ANIMAL-CARDIOGRAM AND PLANT-SPHYGMOGRAM

Effect of	Animal-cardiogram	Plant-sphygmogram
Stimulant	Enhanced frequency or increased amplitude	Increased sap-pressure, up-stroke of pulse larger than down-stroke
Depressant	Diminished frequency or amplitude	Diminished sap-pressure, down-stroke larger than up-stroke

The result, both in animal and plant, is modified (1) by tonic condition of the tissue, and (2) by the dose and the duration of application. Experiments were carried out with the heart of a fish (*Ophiocephalus*) and of the frog, the results obtained being very similar to each other. The effect of drugs on the heart of the fish is described elsewhere.¹ The cardiograms given below were obtained with the heart of the frog. The sphygmograms of the plant were taken with shoots of *Cosmos*, *Centaurea*, and *Antirrhinum*.

EFFECT OF STIMULANTS

Camphor

Experiment 232. *Effect on animal heart.*—Dilute solution of camphor causes an enhancement of the activity

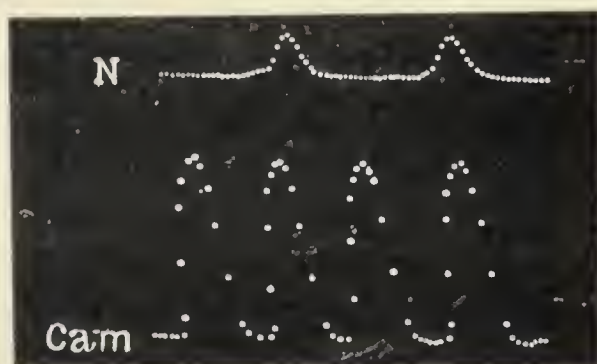

FIG. 227. Effect of dilute solution of Camphor on heart-beat of Frog. Normal feeble pulsation (upper record), enhanced by application of camphor (lower record).

of the animal heart. The stimulative effect is more easily shown with a specimen which is in a somewhat depressed

¹ *Plant-Autographs*, p. 173.

condition. It is obvious that little further enhancement can be induced in a heart that is already in a condition of maximum activity. The record (fig. 227) shows that the feeble activity of the heart was greatly enhanced after the application of dilute solution of camphor. The various solutions may be applied on the heart for absorption, or they may be introduced by hypodermic injection.



FIG. 228. Effect of Camphor in enhancing the sap-pressure by increasing the pumping activity.

Note increase of pressure indicated by up-curve, up-stroke of each pulse larger than down-stroke (*Antirrhinum*).

Experiment 233. *Effect on plant.*—The effect of camphor on the plant is shown in fig. 228; the original amplitude of pulsation in a state of balance was feeble, so the record appears as a horizontal line. Application of dilute camphor produced a sudden increase of pressure, shown by the ascending curve, in which the constituent pulsations show the up-stroke to be larger than the down-stroke.

Musk

I obtained similar results with other stimulants such as musk, provided the dose is not excessive (*see* figs. 230, 231).

EFFECT OF DEPRESSANTS

Morphine may be taken as a typical depressant which lowers the pulsatory activity.

Experiment 234. *Effect on animal heart.*—The normal activity undergoes depression when the narcotic is injected into the heart (*see* fig. 232).

Experiment 235. *Effect on plant.*—The depressing action of morphine on the pulse-beat is shown in the record (fig. 229). The sap-pressure is seen to undergo a rapid depression, the constituent pulsations of the descending curve exhibiting down-strokes of each pulse larger than the up-stroke.

ANTAGONISTIC REACTIONS

The most remarkable results were obtained in both animal and plant by the alternate application of a depressant and a stimulant. For a depressant I used a solution of bromide of potassium.

Experiment 236. *Antagonistic reactions in animal heart.*—After application of solution of bromide of potassium, great depression occurred in the amplitude of pulsation. A solution of musk, one part in a thousand, was next applied; it not only neutralised the depressing action of the bromide, but considerably enhanced the activity (fig. 230).

Experiment 237. *Parallel reactions in plant.*—The effect of bromide was to produce a great depression, the diminished sap-pressure being shown by down-curve of the record, the down-stroke of each pulsation being larger than the up-stroke. Subsequent application of musk caused a great enhancement of pumping activity and resulting increase of pressure (fig. 231).

Such antagonistic reactions are even more strikingly exhibited under the action of a poison and its antidote.

Experiment 238. *Effect of morphine and atropine on animal heart.*—Morphine produced a depression of pulsatory activity. Application of atropine caused a revival by exerting a physiological antagonism to the action of morphine (fig. 232).

Experiment 239. *Effect on plant.*—An exactly parallel effect was produced in the plant; under the continued action of morphine the plant was on the point of death, as shown by



FIG. 229. Depression induced in plant by Morphine. The sap-pressure exhibits a rapid fall (*Antirrhinum*).

the movement of the light-index to the extreme left. Application of atropine, at this stage, renewed the pulsation; the

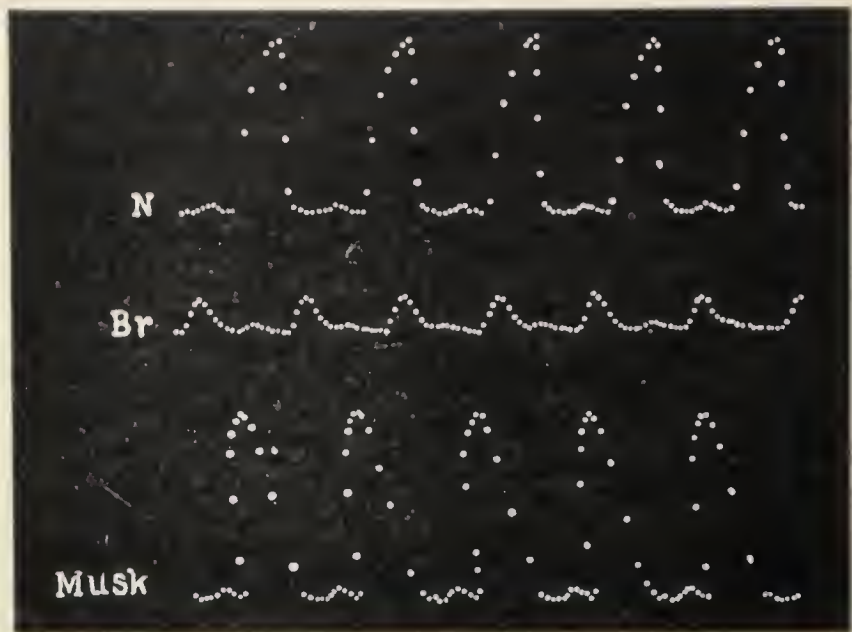

FIG. 230. Antagonistic action of Musk and Bromide of Potassium on heart-beat of Frog.

N, normal; Br, depression induced by KBr solution; Musk, enhanced activity under the reagent.

beam of light now moved to the right, demonstrating the revival of the life-activity.

EFFECT OF STIMULANT-DEPRESSANTS

The effect of these agents is greatly modified by the strength of the dose. A minute dose, generally speaking, induces stimulation, whereas a large dose causes depression which may culminate in death.

Experiment 240. *Effect of strychnine on heart-beat.*—A dose of strychnine, one part in a thousand, caused a marked enhancement of cardiac activity (fig. 233); a 2 per cent. solution produced, on the other hand, great depression and ultimate arrest of the heart-beat.

Experiment 241. *Effects of different doses of strychnine on plant.*—Parallel effects of stimulation and depression were

produced in the plant by minute and large doses of strychnine. A dose of a solution of one part in a thousand acted



FIG. 231. Effect of KBr in depressing and of Musk in enhancing sap-pressure (Impatiens).

as a stimulant ; but a dose of 1 per cent. solution caused marked depression (fig. 234).

ACTION OF COBRA-VENOM

This acts as a deadly poison to both plant and animal. Its subcutaneous injection causes death of the animal in a short time. In the plant likewise it causes death, as evidenced by permanent stoppage of pulsation.

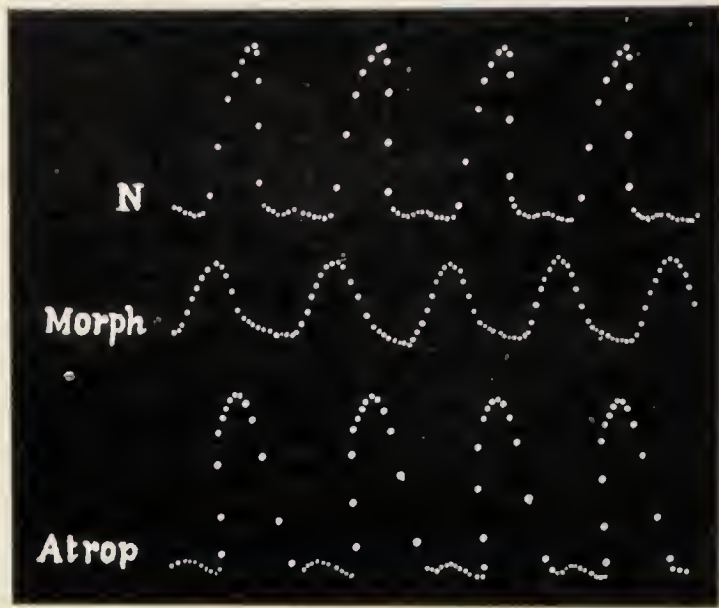

FIG. 232. Effect of Morphine and Atropine on heart-beat of Frog.

N, normal; Morph, depression under morphine ;
Atrop, revived activity under atropine.

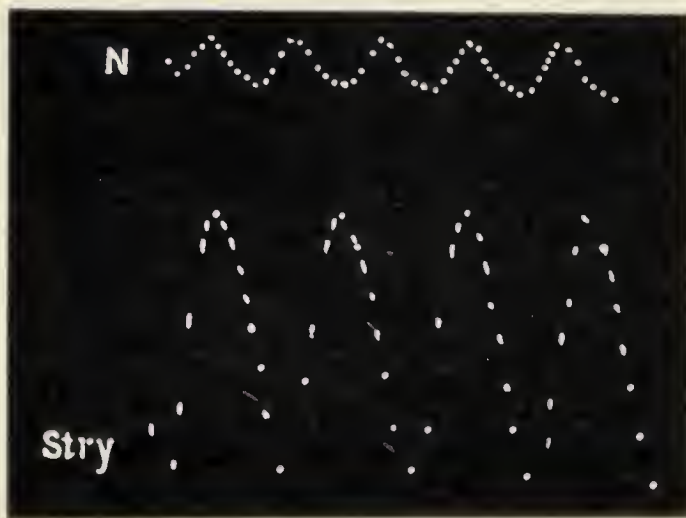

FIG. 233. Effect of dilute Strychnine in stimulating the heart-beat of Frog.

The feeble normal pulsation (upper record) enhanced by application of dilute strychnine (lower record).

A minute dose of the venom is, however, found to produce stimulation both in animal and in plant.



FIG. 234. Action of Strychnine on Plant.

Left : enhancement of sap-pressure under a minute dose.
Right : diminution of sap-pressure under a strong dose (Cosmos).

SUMMARY

Drugs induce, in general, parallel modifications in the pulse-beat of animal and plant. Cardiac stimulants are also found to stimulate the cellular activity in the propulsion of sap, and to produce an increase of sap-pressure. Cardiac depressants, on the other hand, cause a diminution of sap-pressure. Camphor, caffeine, and musk act as stimulants alike for the animal and the plant, while potassium bromide and morphine act as depressants.

The effect of a stimulant can be quickly reversed by that of a depressant. The increase of sap-pressure under camphor,

for example, can be transformed into diminished sap-pressure by KBr, and the two opposite reactions can be alternately induced many times in succession.

The effect of a poisonous drug may likewise be counteracted by the action of an appropriate antidote, as shown by revival of activity by atropine after poisoning by morphine.

A minute dose of strychnine produces similar enhancement of pumping activity in the animal and in the plant. A large dose produces depression or arrest in both.

The effects of cobra-venom on the pulse-beat of the animal and of the plant are remarkably similar; in moderate doses the pulsations are quickly abolished; in minute doses, however, it acts as a stimulant enhancing the rhythmic activity.

These results afford additional and independent proof that the mechanism for the propulsion of sap in the plant is physiological, and is essentially similar in principle to that for the circulation of blood in the animal.

CHAPTER XXIX

THE RESPONSIVE MOVEMENT OF SAP IN SEALED STEMS

AN explanation of the characteristic effects of chemical stimulants and depressants in inducing variations of sap-pressure at the sphygmographic contact described in the previous chapter, which would appear to be satisfactory is :

- (1) That the plant was continually losing water by transpiration.
- (2) That the sap-pressure exerted at the contact-point C is determined by the algebraical summation of the two factors $A - T$; of these A represents the accession of water at the contact point C by suction of water from below, and T the removal of water from C by the transpiration of the leaves higher up on the stem.
- (3) The pressure at C becomes constant when the accession is equal to loss by transpiration ($A = T$).
- (4) Enhancement of rhythmic activity in the propulsion of sap upsets the balance in one direction. A being now greater than T ($A > T$), there is an accumulation of sap at C, with resulting expansion and increase of pressure.
- (5) Depression of rhythmic activity retards the rate of ascent and thereby reduces accession of sap at C, the loss by transpiration remaining the same. The loss being greater than gain ($A < T$), the effect at C is contraction and diminution of pressure.

But this explanation is unsatisfactory because it does not take into account all the relevant facts. It assumes

that the movement of the sap is always ascensional, the direction being determined by the action of transpiration above and of root-pressure below. But it has been pointed

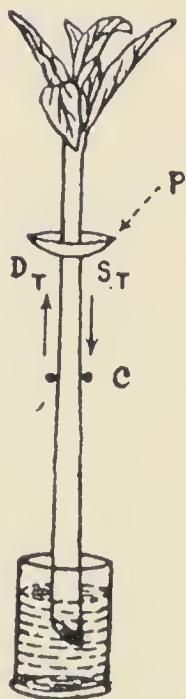

FIG. 235. Effects of thermal stimulation or depression above contact *c*.

A plasticine cup *P* allows application of warm or cold water to the stem for inducing thermal stimulation *S_T* or thermal depression *D_T*. In the first case the induced sap-movement is downwards, and in the second case upwards (*Antirrhinum*).

out in preceding pages that movement of sap can take place in the absence of transpiration as demonstrated by the Method of the Sphygmograph and that of Erectile Response (Experiments 205, 216); and that its direction can be changed by appropriate conditions.

Still more serious is the difficulty encountered in finding an explanation of the following results :

Application of warm water at the cut end of the shoot has been shown to produce an increase of sap-pressure at the sphygmographic contact above (Experiment 228). This was evidently due to an enhanced rhythmic activity inducing the pumping up of water at a quicker rate and producing an increase of pressure; application of cold at the cut end produced a diminution of pressure by depressing the pumping activity. What would happen if heat or cold were applied above the point of contact ?

SPHYGMOGRAPHIC RECORD OF EFFECT OF HEAT AND COLD ABOVE CONTACT

Experiment 242. *Effect of application of heat above.*—I took a cut shoot of *Antirrhinum* and mounted it in the

usual way for recording the sap-pressure at the sphygmographic contact (fig. 235). The following simple device allowed the application of heat or cold above it. A small cup of plasticine was moulded round the stem above the contact-

point ; the object of the cup was to prevent any leakage of the small quantity of warm or cold water applied on the stem for causing local stimulation or depression. As regards the application of heat, one would anticipate that the enhanced rhythmic activity thus induced would increase the rate of the pumping activity, the sap would be carried away at a quicker rate and would cause diminution of pressure below the point of application. The observed result was, however, the opposite : application of heat, instead of inducing a diminution, caused an increase of pressure at the contact-point below.

Experiment 243. *Effect of application of cold.*—The experiment was repeated with this difference, that instead of stimulation by heat, depression was produced by application of cold above the contact. It might be assumed that the pumping activity in this case would be more or less paralysed, and the transport of sap to the transpiring leaves would be reduced. There should then be an accumulation of sap at the contact, resulting in an increase of pressure. But the effect observed was a diminution and not an increase of pressure.

The following results may be taken as typical. Local application of cold and heat were successively applied on an identical specimen above the sphygmographic contact, and the change of pressure induced after 30 seconds observed by noting the deflection of the spot of light. Responsive

TABLE XXIV.—VARIATION OF SAP-PRESSURE BY SUCCESSIVE APPLICATION OF COLD AND HEAT ABOVE CONTACT-POINT (ANTIRRHINUM).

External variation	Induced change of pressure at sphygmographic contact	Deflection
Application of Cold	Diminution of pressure	— 75 mm.
„ „ Heat	Increase „ „	+ 80 mm.

increase of pressure was indicated by deflection of the light to the right (+ deflection), while diminution of pressure

was shown by deflection to the left (— deflection). The scale was placed at a distance of a metre.

These results were not what might have been expected, and evidently called for further investigation.

PHYTOGRAPHIC RECORD OF EFFECT OF HEAT OR COLD

Experiment 244. *Response of leaf to application of heat or cold above.*—Precisely parallel results are obtained when the leaf is utilised as an indicator of the movement of sap. When heat is applied to the stem above the leaf, it exhibits an erectile response evidently due to the forcing in of sap downwards. Application of cold, on the other hand, causes a responsive fall of the leaf, due to the flowing away of sap. These definite effects, recorded by the two different methods of the Sphygmograph and the Phytograph, cannot be explained on the hypothesis that the upward movement of sap is the fundamental reaction, all other results being merely due to modification of the rate of ascent, either increase or diminution. The unfounded character of this hypothesis is demonstrated by the experiments just described; very definite results have been obtained, which indicate that under certain specific conditions the direction of movement of the sap undergoes a complete reversal from up to down. It is evident that the old theory must be replaced by a universal law based on the facts of the directive movement of the sap.

The experiments that have been described in previous chapters may be divided into two classes, as follows :

- (1) Those of the ascent of sap in which water was absorbed at the lower end and excreted at the upper end by the transpiring leaves.
- (2) Those of the movement of sap in bare varnished stems, in which the transpiration-current was completely eliminated. In spite of this, application of heat at the lower end caused an up-movement of sap, while its application at the upper end caused a down-movement (Experiments 217–220).

The results prove that transpiration is by no means essential to the propulsion of sap. What would happen if both absorption and transpiration were completely eliminated? Would the responsive movement of sap, and variation of pressure induced by it, undergo abolition? In order to answer the question thus raised, I made experiments with bare stems which were completely sealed, so that there could be no accession of water by absorption nor any loss by transpiration. The detection of responsive movement of sap under these conditions might, it was hoped, lead to the discovery of the basic activity in the propulsion of the sap.

For sealing the stems I employ a mixture of coconut oil and solid paraffin, which melts under a slight rise of temperature and solidifies on return to the temperature of the room. The most sensitive specimens for the investigation are young stems of *Cosmos* and *Antirrhinum*; failing these the petiole of Tomato may be employed, though it is considerably less sensitive. A piece of bare stem or a petiole, about 70 mm. in length, is taken and completely sealed by means of the impermeable varnish.

DETECTION OF SAP-MOVEMENT BY SPHYGMOGRAPH

How can a sap-movement induced in a sealed stem be detected? I have shown that the passage of the peristaltic wave carrying the sap can be detected by means of the Sphygmograph; that the *flowing in of sap causes expansion and increase of pressure at the contact, whereas withdrawal or movement of sap away from the contact is indicated by contraction and diminution of pressure* (Experiment 204). In order to carry out experiments on peristalsis in the plant parallel to those on the animal stomach, I devised a modified form of the Optical Sphygmograph. The experimental stem is held horizontal between two vertical rods, one fixed and the other movable (*cf.* fig. 176). The movement of the primary movable lever is further magnified by a reflected beam of

light, as in the Optical Sphygmograph (*cf.* fig. 221). Observations were commenced a short time after the preliminary adjustment, so as to allow disappearance of the irritation caused by handling. After subsidence of irritation the pressure at the contact was found to remain constant, indicating that the sap was in a state of standstill.

INDUCTION OF SAP-MOVEMENT IN SEALED STEMS

The sphygmographic contact is made at the middle of the stem. The sap, as already stated, is in a state of standstill at the beginning, as indicated by the sap-pressure at the contact remaining constant. The initiation of sap-movement under external change can be detected, as previously explained, by the observed variation of pressure. An increase of pressure, shown by the positive deflection of the spot of light to the right (up-curve in record), indicates a responsive movement of sap towards the contact. A diminution of pressure, shown by the negative deflection (down-curve in record), indicates, on the other hand, a movement of sap away from the contact.

Reference to the generation of peristaltic waves by external stimulation described in a previous chapter (pp. 288, 289), will show that the experiment on the bare and sealed stem is analogous to that on the isolated stomach, the activity of both being at standstill. It was shown that local stimulation applied at the more excitable upper end of the stomach gave rise to a peristaltic wave in the normal direction of propagation; stimulation at the less excitable pyloric end gave rise, on the other hand, to an antiperistaltic wave in the reverse direction, the effectiveness of which was 3 to 4 times less than that of the peristaltic wave in the normal direction. Among the modes of stimulation found effective in initiating peristalsis of the stomach were: (1) electric stimulation, (2) chemical stimulation, and (3) thermal stimulation.

Would the bare and sealed stem exhibit peristaltic

movement of sap on stimulation? From the ordinarily accepted point of view, nothing could be more unlikely; for under the special conditions of the experiment, the accession and removal of water at the two ends of the organ on which the movement of sap is supposed to depend are completely eliminated. The question was put to experimental test, by subjecting one or the other end of the organ to various modes of stimulation, electric, chemical, or thermal.

I describe first the method of electric stimulation by tetanising induction-shocks of moderate intensity, applied (1) below the contact, (2) above the contact, and (3) both below and above the contact simultaneously. Two platinum pins were thrust, 5 mm. apart, into the stem for the passage



FIG. 236. Application of electric stimulation S_E below contact, and S'_E above contact c .

A is the apical, and B the basal end of the stem. The direction of arrow indicates the direction of responsive propulsion of sap.

of the shock, the stem being kept sealed and dry. Electric stimulation has this advantage, that its intensity can be maintained constant in successive experiments.

The experimental method is diagrammatically represented in fig. 236. The sealed stem is represented by A B, of which A is the apical, and B the basal end. The direction of the peristaltic wave causing the normal ascent in the intact plant is upwards from B to A. The specimens which give the best results are young stems¹ in which the rate of ascent is most rapid, such as *Cosmos* and *Antirrhinum* in their proper season. It is better to choose stems which are in a condition of moderate drought, for over-distension is unfavourable for the transmission of the contractile wave. The point of

¹ In young stems the nervous tissue is but feebly developed; there is therefore no transmission of excitatory impulse, specially when the stimulation is of moderate intensity.

application of stimulus is at a distance of about 15 mm. from the sphygmographic contact. Electric stimulation applied on the right, or below the contact, is distinguished by the symbol S_E ; stimulation on the left, or above the contact, is indicated by S'_E .

EFFECT OF ELECTRIC STIMULATION

Experiment 245. *Electric stimulation below contact.*— This and the following experiments were carried out with an identical sealed stem of Cosmos. Stimulation on the right or towards the basal end caused, in the course of 2 minutes, an increase of pressure at the contact-point above, indicated by a deflection of + 400 mm. This increase of pressure, as previously explained, is caused by the sap being forced into the region of contact by a peristaltic impulse in the same direction as that of the normal rise of sap. *Stimulation thus initiated a movement of sap in the quiescent stem, the sap-flow being directed from the stimulated point to the unstimulated region of the contact.*

Experiment 246. *Electric stimulation above contact.*— Stimulation of the same intensity applied at the same distance above the contact gave rise to an antiperistaltic impulse, which also caused an increase of pressure measured by a deflection of + 100 mm. It may be asked why stimulation, applied either above or below, should produce in every case an increase of pressure. Again, why should the effect of the peristaltic wave be greater than that of the antiperistaltic wave? I will presently explain the cause of the difference.

Photographic records of the effects of electric stimulations of the same intensity applied successively below and above the contact are given in fig. 237. In the first case the transmission is peristaltic, in the second antiperistaltic. The characteristic difference in the effects transmitted in the two directions is quite evident, the peristaltic reaction being about 3 times more intense.

Experiment 247. *Effect of simultaneous electric stimulation below and above the contact.*—Stimulations below and

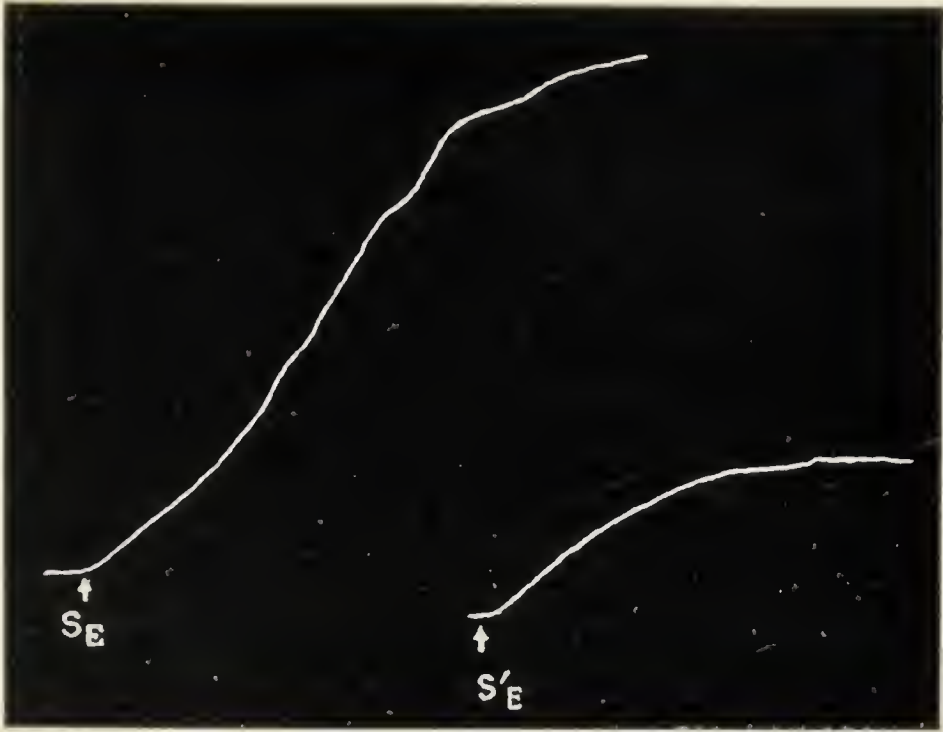

FIG. 237. Record of transmitted effect of electric stimulation S_E below, and S'_E above contact.

Note greater effect of peristaltic transmission.

above the contact have been shown to produce similar effects. Their simultaneous effect is clearly additive, since the result actually obtained was a response of larger amplitude.

PERISTALTIC AND ANTIPERISTALTIC WAVES IN STOMACH AND IN STEM

In the experiments described above the responsive flow of sap was from the stimulated end, basal or apical, towards the unstimulated point of contact. *The flow of sap followed the stimulation-gradient from the point activated by stimulation to the contact-point which had not been so activated.* The results obtained with a sealed stem with its activity at standstill are thus exactly parallel to those obtained with the quiescent stomach. In both, peristaltic or antiperistaltic

waves are generated by stimulation, the direction of propagation of which is from the more stimulated towards the less stimulated end. Moreover, the peristaltic wave in both is at least 3 times more intense than the antiperistaltic wave. The facts of peristalsis under electric stimulation are thus identical in the plant and in the animal; it has now to be ascertained whether this is equally true in regard to chemical and thermal stimulation.

EFFECT OF CHEMICAL STIMULATION

The stimulating action of a drug, camphor for example, was demonstrated in a previous chapter by its enhancing the rate of ascent of sap in a cut stem bearing leaves. In the condition of balance, the pressure at the sphygmographic contact was constant; application of a chemical stimulant was shown to produce an upsetting of the balance due to an increase of pressure (Experiment 233). The conditions of the experiment with the sealed stem are, however, very different, inasmuch as the propulsive cells are in a state of quiescence to begin with. Any movement of sap that may be induced must therefore be due to the initiation of peristalsis by the chemical stimulation.

The sealed stem was cleared of varnish for a short length to the right and to the left of the contact, and the epidermis slightly abraded for the application of a small quantity of the stimulant with a camel-hair brush. Inasmuch as the stem was sealed, there was no suction exerted by transpiration, so that the quantity of solution absorbed at the abraded point was minute and practically negligible. The induced movement of sap observed was therefore due, not to the absorption of the minute quantity of the chemical solution, but to its stimulating action. That the absorption of the solution itself had nothing to do with the directive movement of sap is demonstrated by the action of a depressant solution, which caused a reversal in the direction of propulsion (Experiment 250).

Experiment 248. *Chemical stimulation below contact.*—The effect of stimulation by camphor was a positive deflection indicating an increase of pressure at the sphygmographic contact. The peristaltic wave thus initiated had caused a movement of the sap, forcing it into the region of contact.

Experiment 249. *Chemical stimulation above contact.*—The effect was the same as in the last case, namely, an increase of pressure at the sphygmographic contact. The impulse in this case was antiperistaltic, the sap being forced downwards into the contact region, against the direction of the normal ascent (upper diagram, fig. 238).

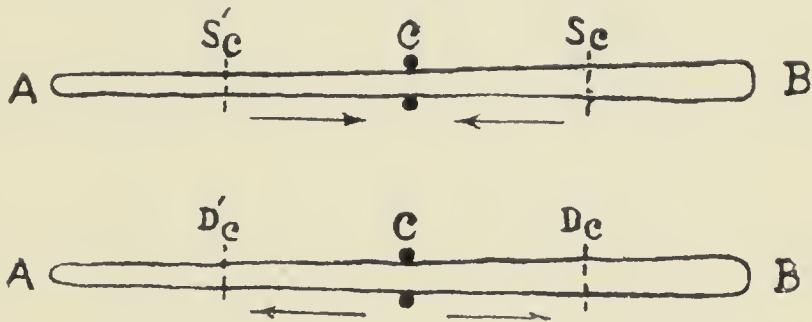

FIG. 238. Diagrammatic representation of effects of chemical stimulant and depressant.

Chemical stimulation s'_c below, induced peristaltic movement of sap towards contact c shown by arrow. Chemical stimulation s_c above contact, induced antiperistaltic movement of sap towards c (upper figure). Chemical depressant applied either D_c below or D'_c above, induced movement of sap away from contact c (lower figure).

EFFECT OF CHEMICAL DEPRESSANT

The effect of a depressant was precisely opposite to that of a stimulant.

Experiment 250. A solution of a chemical depressant, bromide of potassium, was applied successively below and above the sphygmographic contact. In both cases a diminution of pressure was recorded, due to removal or withdrawal of sap from the contact-region. The effect of the application of a depressant in initiating movement of sap away from the contact is represented in the lower diagram of fig. 238.

Experiment 25I. *Effect of alternate application of stimulant and depressant.*—Chemical stimulation, whether above or below the contact, has been shown to produce an increase of pressure there, the effects being concordant. Simultaneous application of a stimulant above and below the sphygmographic contact was therefore found to produce an additive effect of increased pressure. Similarly, simultaneous application of a depressant above and below induced

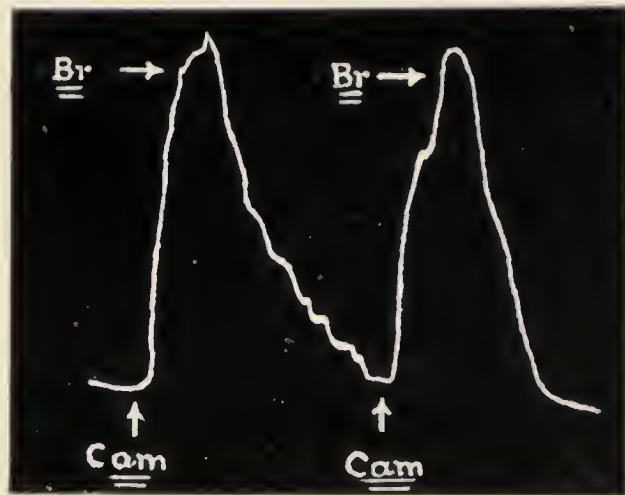

FIG. 239. Increase of pressure and movement of sap *towards* contact induced by simultaneous application of camphor Cam below and above contact. Simultaneous application of bromide Br both below and above reversed the direction of movement of sap *away from* contact. Effects are repeated in second series.

a great diminution of pressure. The alternating increase and diminution of pressure are exhibited in the record (fig. 239), in which simultaneous application of solution of camphor above and below produced a great increase of pressure, shown by the up-curve; simultaneous application of potassium bromide above and below not only arrested the impulse, but reversed the response into one of marked diminution of pressure. The alternating positive and negative responses were obtained many times in succession (fig. 239).

In both these cases the movement of sap is from the stimulated to the less stimulated or depressed region.

Chemical stimulation above or below caused sap-movement *towards the unstimulated point of contact*. Chemical depressants applied above or below made the sap *flow away from the contact*, which was relatively speaking the more active region. The following tabular statement clearly presents the different results :

TABLE XXV.—EFFECTS OF CHEMICAL STIMULANT AND DEPRESSANT APPLIED AT TWO ENDS OF THE ORGAN.

Initiation of enhanced or depressed activity	Impulse from more to less active region	Response at sphygmographic contact
Stimulation below point of contact	Peristaltic wave ; sap-movement towards contact	Expansion and increase of pressure
Stimulation above point of contact	Antiperistaltic wave ; sap-movement towards contact	Expansion and increase of pressure
Depression below point of contact	Antiperistaltic wave ; sap-movement away from contact	Contraction and diminution of pressure
Depression above point of contact	Peristaltic wave ; sap-movement away from contact	Contraction and diminution of pressure

Movement of sap transporting chemical substances in leafless trees in spring.—The young spring buds on the leafless trees require a supply of chemical substances for their development. These substances, stored at a distance, can only be transported in solution to the growing-points by the movement of the sap. The foregoing experimental results suggest the satisfactory explanation of the necessary directive movement of sap, that it is attributable to differential chemical stimulation.

I next describe the effects of thermal change in initiating the movement of sap. Application of heat has been shown to enhance the rhythmic propulsive activity, whereas cold caused depression (Experiment 197). The directive movement of sap under thermal stimulation or depression has been fully demonstrated by means of the Potograph

(Chapter XXV), the movement induced being indicated by the positive or negative excursion of the water-index. The direction of propulsion was found to be always from the more to the less stimulated or depressed end (Experiments 217-221).

In the present case the conditions of the experiment, as well as the method of detection of the movement of sap, are very different. The stem, in the first place, is completely sealed; and the initiation of sap-movement is detected by the Sphygmograph. The results obtained by methods so widely different are, however, in absolute agreement with each other.

As one of the objects of the investigation was the demonstration of the identical reaction of plant and animal, I at

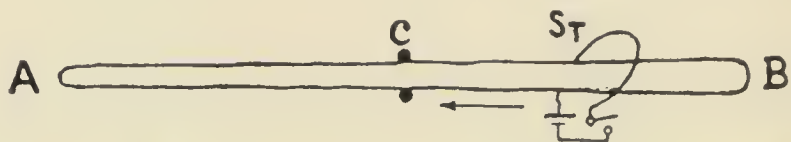

FIG. 240. Method of thermal stimulation by loop of wire heated by passage of an electric current.

first used the well-known means that has been employed for local stimulation of different regions of the heart, by a loop of electrically heated wire. Thermal stimulation of the ventricle was thus found to enhance its activity, as shown by an increased amplitude of pulsation. A precisely similar method was employed for local stimulation of the stem, either below or above the contact; or both below and above the contact simultaneously.

Thermal stimulation can also be effected more simply by applying, by means of a pipette, a small quantity of warm water on a particular point in the stem, round which is wrapped a piece of tinfoil. Stimulation by variation of temperature can thus be produced without the possibility of introduction of water into the tissue. The characteristic results were found to be in every way similar whether the stimulation was produced by a loop of electrically heated

wire, or by application of warm water. I describe typical results obtained, first with the sealed stem of *Cosmos*; thermal stimulation was successively applied below and above the sphygmographic contact at a distance of 15 mm.; the resulting variation was observed after an interval of 30 seconds.

EFFECT OF THERMAL STIMULATION

Experiment 252. *Thermal stimulation below*.—This induced sap-movement upwards, the wave being peristaltic. The time of transmission of the impulse to the sphygmographic contact was found to be 4 seconds. The increase of pressure produced a deflection of + 1200 mm. The next experiment was continued with the same plant.

Experiment 253. *Thermal stimulation above*.—This caused a movement of sap downwards against the direction of normal ascent. The time of the antiperistaltic transmission was 11 seconds, that is, nearly 3 times longer than that of the peristaltic wave. The response by pressure-variation was of the same sign as in the last case, the deflection being + 400 mm.

The notable fact is that thermal stimulation whether above or below the contact induces the same effect, namely, an increase of sap-pressure at that point. The induced movement of sap, as in the case of other modes of stimulation, is from the more to the less stimulated region.

The above results were obtained with *Cosmos* at its best season, at the beginning of February. By the end of March the plants had grown too old, resulting in a considerable decline of sensitivity. I was therefore obliged to continue the investigation with other species of plants, which, though less sensitive, still gave consistent results, as summarised below.

It is very significant that, as in the stomach so also in the stem, the effect of the antiperistaltic wave is about a third of that of the peristaltic wave. This was found to be of

general occurrence in young internodes of plants. On account of lignification in the older internodes, the sensitivity falls rapidly downwards.

TABLE XXVI.—EFFECT OF THERMAL STIMULATION APPLIED BELOW AND ABOVE THE SPHYGMOGRAPHIC CONTACT.

Specimen	Point of application of stimulation in relation to the sphygmographic contact	Transmitted wave	Response by increase of pressure (deflection in mm.)
Cosmos (late in season)	Stimulation below	Peristaltic	+ 750 mm.
	Stimulation above	Antiperistaltic	+ 250 mm.
Dahlia	Stimulation below	Peristaltic	+ 250 mm.
	Stimulation above	Antiperistaltic	+ 60 mm.
Tomato (Petiole)	Stimulation below	Peristaltic	+ 600 mm.
	Stimulation above	Antiperistaltic	+ 200 mm.

Experiment 254. *Summated effect of simultaneous thermal stimulation below and above contact.*—As the sign of the two responses is the same, the effect of simultaneous stimulation below and above the contact is found to be additive.

PHYSIOLOGICAL CHARACTER OF RESPONSE

Experiment 255. *Abolition of response after death.*—This was demonstrated by experiments carried out with a stem the cut end of which was placed in a toxic solution of KCN. The whole length of the stem became gradually killed from below upwards by the slow absorption of the poison, in the course of half an hour or so. A sealed specimen of the poisoned stem showed no sap-movement under thermal stimulation.

Experiment 256. *Effect of stimulation of stem killed through half its length.*—A very interesting result is obtained when the specimen is not kept too long with its lower end in the solution of poison. Under such circumstances it is only the lower half of the stem that is killed, the poison not

having yet reached the upper half. Thus a specimen of Sunflower that had been kept in a poisonous solution for 20 minutes, gave no response to thermal stimulation applied below the sphygmographic contact. Stimulation of the unkilld portion above the contact gave, however, an antiperistaltic response of increase of pressure, the deflection being 250 mm. Similarly, stimulation of the killed lower half of the stem of Cosmos gave rise to no response, while stimulation of the living upper half evoked a responsive antiperistaltic movement of the sap, giving a deflection of + 150 mm.

EFFECT OF THERMAL DEPRESSION

Application of cold induces the reaction of depression. The following experiments were carried out with Cosmos.

Experiment 257. *Application of cold below the sphygmographic contact.*—This resulted in a diminution of pressure at the contact, measured by a deflection of — 100 mm. This diminution, as previously explained, is due to movement of sap away from the contact.

Experiment 258. *Application of cold above the contact.*—A diminution of pressure occurred in a different specimen on application of cold at a point above the contact. This diminution was indicated by a deflection of — 150 mm.

These results are now easily explained on the general principle or Law of Peristaltic Movement of Sap already established, that the responsive flow is from the more stimulated to the less stimulated or depressed region. In the case of depression of activity induced by cold, the sphygmographic point of contact is relatively the more active. Hence the sap flows away from it to the depressed lower or upper ends, resulting in contraction or diminution of pressure at the contact.

Experiment 259. *Effect of alternate thermal stimulation and depression above and below.*—I give a series of results obtained with an identical specimen of Cosmos under the

398 CHAP. XXIX. MOVEMENT OF SAP IN SEALED STEMS following sequence of operation. The general results are shown diagrammatically in fig. 24I.

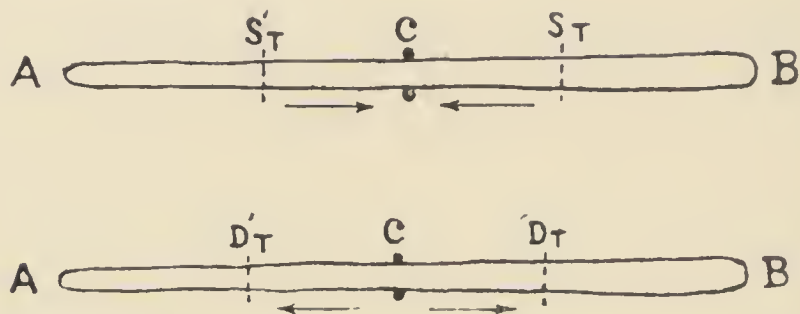

FIG. 24I. Effect of thermal stimulation and depression. Heat s_T applied below and s'_T above the contact. Responsive flow of sap towards the unstimulated contact-point c (upper figure). Cold D_T and D'_T applied below and above the contact. Responsive flow of sap from the relatively more active c to the depressed regions D_T, D'_T (lower figure).

- (1) S_T , thermal stimulation below sphygmographic contact.
- (2) D_T , thermal depression below contact.
- (3) S'_T , thermal stimulation above contact.
- (4) D'_T , thermal depression above contact.

TABLE XXVII.—EFFECTS OF FOUR CYCLES OF THERMAL STIMULATION AND DEPRESSION (COSMOS).

Stimulation or depression	Observed variation of pressure : + increase ; - decrease	Responsive movement of sap
S_T	Increase of pressure + 450 mm.	Towards the contact from the stimulated and activated point below
D_T	Diminution of pressure - 200 mm.	Away from the relatively active point of contact to the depressed region below
S'_T	Increase of pressure + 150 mm.	Towards the contact from the stimulated point above
D'_T	Diminution of pressure - 250 mm.	Away from the relatively active point of contact to the depressed region above

The demonstrations given above offer full explanation of apparently capricious results described in Experiments 242

and 243, in which local application of heat above the sphygmographic contact gave rise to an increase of pressure, while application of cold above caused a diminution of pressure. In both these cases the observed variation of pressure illustrates the law that the flow of sap is from the more active to the less active region. In the first case the increase of pressure was due to the movement and forcing in of sap to the less active contact-region. In the second case the diminution of pressure was due to the flowing away of sap from the relatively active contact-region to the depressed region above.

Experiment 260. *Effect of simultaneous stimulation or depression at the two ends.*—Thermal stimulation below or above induces in each case an increase of pressure at the sphygmographic contact; depression caused by application of cold below and above induces a diminution of pressure. The effects of alternate simultaneous stimulation and depression both below and above the contact are shown in the photographic record given in fig. 242. These alternating directions of flow of sap induced in response to stimulation and depression can be recorded many times in succession.

Thermal stimulation thus induces effects which are precisely similar to those obtained under other modes of stimulation, such as electric or chemical. The law of peristaltic propagation is now established on a wide and firm basis, including as it does the reactions of both animal and plant.

The experiments described in this chapter profoundly modify the conceptions hitherto held in regard to the movement of the sap in the stem. This has been regarded as fundamentally dependent upon the absorption of water at one end and transpiration of it at the other. The persistence of the movement of sap in the absence of either accession or loss of water shows the groundlessness of this hypothesis. It proves that the propulsive activity is by no means confined to the terminal organs but exists in the active cortex throughout the length of the stem. Propulsion may be in

a dormant state, or the sap may be at standstill in the condition of balance. Diverse modes of stimulation, electric, chemical, or thermal, awaken the dormant tissue or activate it above the normal. A movement of the sap is thus initiated in a quiescent tissue, and the direction of its propagation can be expressed by the general statement that the sap flows

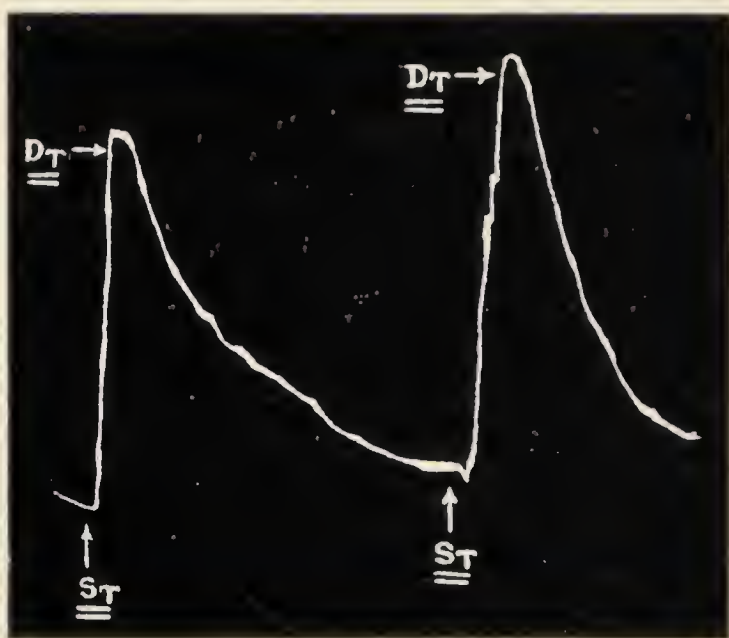

FIG. 242. Effects of alternate thermal stimulation and depression.

Stimulation by heat $\underline{\underline{s_T}}$ applied simultaneously below and above contact, with resulting increase of pressure at contact (up-curve). Simultaneous depression by cold $\underline{\underline{D_T}}$ above and below contact induced diminution of pressure (down-curve).

from the stimulated to the indifferent or depressed region. The normal ascent of sap is only an instance of the effect of differential stimulation, the direction of flow being from the root of the plant, activated by hydrostatic distension due to absorption of water, to the apex of the stem depressed by partial drought caused by the transpiration from the leaves. The sap-flow becomes reversed if the plant be irrigated at the upper instead of the lower end.

INTERCOMMUNICATION BETWEEN DISTANT ORGANS

The conception that the sap moves only in an upward direction has stood in the way of the recognition of the important part played by the circulation of sap in establishing hydraulic means of communication between distant organs. I have explained elsewhere that :

‘The plant is a multicellular organism, and hence necessity arises for intercommunication and interaction between more or less distant organs. This is accomplished in two different ways: *by transfer of matter* and *by transmission of motion*. The first is exemplified by the hydraulic convection of liquids carrying chemical substances in solution, such as occurs in the circulation of sap; the second by the conduction of excitatory change along nerves.’¹

The intercommunication between distant organs by transference of liquid is thus brought about by differential stimulation. The cellular mechanism for directing the flow of sap is highly sensitive, and is automatically adjusted for subserving the well-being of the plant. A local depression or stimulation starts the alert machinery into action, making the sap rush towards the depressed, or away from the overstimulated, region. The peristaltic or antiperistaltic waves of cellular contraction, which cause the movement of sap upwards or downwards, are in constant operation.

In the animal, chemical substances, termed hormones, produced in certain organs, are carried in the circulating blood to the various organs or parts of the body, in which their regulatory action becomes manifested. It is undoubted that hormones are likewise produced in plants, and that these chemical substances, produced in one organ, are conveyed to distant organs in the sap distributed by cellular activity. The distant members of the plant-body are thus linked together in an organised unity.

¹ *Physiology of the Ascent of Sap* (1923), p. 269.

SUMMARY

Investigations on the propulsion of sap were undertaken with bare sealed stems, the factors of absorption and transpiration being completely eliminated. Propulsion, in these circumstances, was in a state of standstill.

Stimulation initiated the movement of sap, the direction of which was from the more to the less activated region. The sap could be made to flow not only upwards, but downwards as well.

The responsive movement of sap occurred under different modes of stimulation, mechanical, electric, chemical, and thermal. Response was abolished after the poisoning of the tissue, proving its physiological character.

The results obtained with the sealed stem with its activity at standstill are exactly parallel to those obtained with the quiescent stomach. In both, peristaltic and antiperistaltic waves are generated by stimulation, the direction of propagation being always from the more to the less activated region. The peristaltic wave in both is about 4 times more intense than the antiperistaltic wave. The law of the propagation of the peristaltic wave is established on a wide and firm basis, including reactions of both animal and plant.

The plant is constituted an organised unity by intercommunication and interaction between distant organs. This is accomplished quickly by transmission of motion as in the nervous impulse, and slowly by the transfer of liquid carrying chemical substances in solution, such as occurs in the circulation of sap.

CHAPTER XXX

GENERAL REVIEW

UNICELLULAR organisms exhibit contractility, rhythmicity, and conductivity, which are different aspects of a fundamental protoplasmic reaction. These characteristics of the unicellular organism persist when cell-complexes and tissue-systems are formed in multicellular organisms. In the associated physiological division of labour, each particular tissue becomes specialised to discharge a given function in a more efficient manner.

The exhibition of contractility and irritability, obvious in the case of the locomotory animal, is so much less so in the sessile plant that, beyond the exceptional sensitivity and movements of 'sensitive' plants, it has been tacitly assumed that plants in general are neither excitable nor capable of movement. This is the matter specially dealt with in several chapters of this book.

Beginning with the sensitives, overwhelming evidence has been adduced that their sensitiveness to stimulation, the conduction of excitation, and the consequent responsive movement, are accompanied by the physiological signs, notably the negative electromotive variation, which have long been known to accompany these phenomena in the animal body.

But the matter has been carried further; no generalisation can be based on sensitives alone. Observation must be extended to include the generality of plants which make no obvious motile response to stimulation from without. These plants cannot execute responsive movements on account of

their anatomical structure. It has, however, been shown by conclusive experiments that these apparently insensitive and immotile 'ordinary' plants respond to stimulation by the infallible sign of negative electromotive variation.

Though ordinary plants do not exhibit such conspicuous movements as do the sensitives, they do nevertheless respond to stimulation by movement; but a movement so slight that it can only be detected by special sensitive apparatus which at the same time magnifies the movement sufficiently to make record of it possible.

THE MOTO-EXCITABILITY OF ALL PLANTS

The apparent absence of mechanical response in ordinary plants is principally due to the inflexibility of the wood with which the living tissue is connected. Contractile movement has, however, been recorded in the diametric contraction of the stem under electric stimulation, due to the moto-excitability of the cortical tissue. For this demonstration I first determined the diametric contraction of the pulvinus of *Mimosa*; afterwards, employing the same method, I measured the contraction of the cortex of its stem. Finally, the diametric contraction of the stem in ordinary plants was determined.

Measurement of the diametric contraction of an active cell of the pulvinus of Mimosa.—By means of the Cell-Sphygmograph the amount of the contraction of a single cell of the pulvinus has been determined. The leaf was kept restrained from movement, a condition approximating to the immotility of ordinary plants. The average diameter of an active cell is 0.024 mm. and the diametric contraction under feeble electric stimulation is 0.76 μ , the micron μ being a millionth part of a metre. The amount of contraction under feeble stimulation is 3.2 per cent., increased to 13.3 per cent. under strong stimulation (p. 137).

Diametric contraction of cortex in the stem of Mimosa.—The cortical cells in the stem also undergo contraction.

Each cell is 0.014 mm. in diameter, and the diametric contraction under feeble stimulation is 0.29 μ , the amount being 2 per cent. (p. 140), and of the same order as that of the active cell in the pulvinus.

Diametric contraction of stem of ordinary plants.—Similar results were obtained with the cortex of ordinary plants, which exhibit marked contraction under stimulation. It was an unexpected revelation to find that the sensitivity of even the ordinary cortex is often exceptionally high, response by contraction taking place under an intensity of electric stimulation which is below the threshold of human perception (p. 145). The plant thus registers impressions of extraordinarily feeble stimulations.

The responsive movements of ordinary plants differ from those of sensitive plants in degree only, just as the movements of the sensitive plants differ from those of animals in degree but not in kind.

RESPONSE OF RADIAL AND ANISOTROPIC ORGANS

It has been possible to trace a continuity of response in radial and in pronouncedly anisotropic organs such as the pulvinus of *Mimosa*, in which excitation is followed by the impulsive and very striking movement of the fall of the leaf.

Radial organ.—A radial organ such as a stem subjected to diffuse stimulation does not exhibit any markedly visible movement as does the leaf of *Mimosa*. The difference is apparent and not real. In a radial organ the excitability is equal on all sides; hence the response cannot be one of bending to one side or the other. Nevertheless, contraction is induced, and is manifested as a shortening of the length of the organ (p. 151).

Tropic curvature of radial organs.—A bending movement is, however, produced in a radial organ under unilateral stimulation, the stimulated side becoming contracted and concave (p. 152). This fact offers a satisfactory explanation

of the tropic curvature induced under diverse modes of unilateral stimulation.

Transient anisotropy.—Between the radial and the pronouncedly anisotropic is the intermediate type of organ, which exhibits transient anisotropy. Under geotropic action, a horizontally laid radial organ becomes curved and anisotropic, the curvature and induced anisotropy being reversed when it is rotated through 180° round the horizontal axis. The convex side of the organ is found to be the more excitable; hence diffuse stimulation causes a flattening of the curvature. The changing physiological differentiation in an originally radial organ is manifested by a definite sequence of transformation from an up-response through intermediate zero to a down-response (p. 155).

The tissue which is active in all the forms of movement described is the cortex; it is continuous, both structurally and functionally, throughout the body of the plant, not only in the sensitive but also in the ordinary plant. Drought or withdrawal of water under plasmolysis induces similar shrinkage or contraction in the stem and in the leaf-joint of ordinary plants as it does in the pulvinus of *Mimosa*. Supply of water, on the other hand, induces expansive response in all these organs. In contrast with the slow contraction by removal of water under drought or plasmolysis, is the sudden contraction induced by external stimulation (p. 160).

Having shown the continuity of contractile reaction in the cortical tissue, the detailed study of the phenomenon of contraction is facilitated by the results of the experiments carried out with *Mimosa pudica*.

CONTRACTILE RESPONSE

The mechanical response of *Mimosa* was obtained not only with the intact plant, but also with the petiole-pulvinus preparation, which functions like the nerve-and-muscle of the animal (p. 79). The method of experimentation was

further simplified by the discovery that the irritability persisted in the isolated pulvinus as it does in the isolated muscle of the frog (p. 119).

The fact that the fall of the leaf of *Mimosa* under stimulation is not due to the passive yielding of the flaccid pulvinus, but to active contraction, is demonstrated by the vigorous contractile response exhibited by the plant held in an inverted position, the leaf being now lifted against the force of gravity (p. 33).

The rapidity of contraction.—The presence of an 'active' substance apparently confers on the motor organ its power of rapid contraction. The highly contractile cells of the pulvinus are demarcated from others by the differential action of stains. The distribution of the stainable active substance affords a measure of the rapidity of contraction of the motor organ. In the semi-active *Neptunia*, the active cells are more sparsely distributed than in *Mimosa*. The relatively inactive pulvinus of *Phaseolus* contains no trace of the active substance (p. 64).

Modifying effect of tonic condition on response.—Stimulation does not always cause a depletion or run-down of energy (symbolised as the D-reaction); under certain conditions it causes an accession or storage of energy (A-reaction), as when the leaf of *Mimosa* in a subtonic condition exhibits an erectile response under stimulation. The relative intensity of the two reactions is modified in a definite manner according to the tonic condition of the tissue. When the tonic level is *above par*, the D-reaction is predominant ($D > A$); but when the tonic level is *below par*, the accession of energy is the more pronounced ($A > D$). Stimulation effects both internal and external work, the relative values of which undergo progressive change. The 'trigger action' is only a particular event in the tonic cycle (pp. 51, 57).

Diurnal variation of moto-excitability.—The excitability of *Mimosa* does not remain constant, but undergoes characteristic variation at different hours. In the spring, the excitability attains its maximum value at midday and

remains constant for several hours. There is then a continuous fall of excitability till the minimum is reached at about 8 in the morning, when the plant is practically insensitive. The excitability is then gradually restored in a staircase manner, till the maximum is reached once more at 12 noon. The diurnal variation is primarily due to the hourly variation of temperature, the effect being modified in a less degree by variation of light (p. 97).

Common characteristics of contractile response in plant and animal.—Stimulation individually ineffective becomes effective after repetition (p. 46). In a slightly subtonic condition the tissue exhibits a staircase response under successive equal stimulations (p. 52). A fatigue-relaxation occurs under continuous stimulation (p. 48). There is an inhibition of response when the contractile tissue, pulvinus or muscle, becomes water-logged by excessive absorption of water (p. 70). The amplitude of response is determined by the number of cells that undergo contraction (p. 40). Contractility in both cases is temporarily abolished at a thermometric minimum; the amplitude of response is maximum at an optimum temperature, and there is a decline of excitability above the optimum.

Effect of drugs.—The action of anæsthetics and drugs is, in general, remarkably similar in plant and animal tissues. Vapour of ether exerts a moderate narcotic action, inducing a temporary abolition of excitability which is restored on readmission of fresh air (p. 75). Chloroform is a stronger narcotic, excessive application of which causes death (p. 76). The action of BaCl_2 on the pulvinus, like that on the animal muscle, is a prolongation of the period of recovery and a characteristic double-contraction. The response becomes normal after a short period of tetanisation (p. 87). Acid and alkali are antagonistic in their reactions (p. 88). Dilute solution of camphor enhances the excitability of the pulvinus, as it does that of the muscle (p. 124). The effect of strychnine is similar in plant and animal, a minute dose inducing a great increase of excitability (p. 127), while a larger dose

abolishes it. A minute dose of a toxic agent often exerts a stimulating action.

Polar action of constant current in excitation.—It has been supposed that the laws of polar action on non-fibrillated protoplasm are different from those on highly differentiated animal muscle. My experiments on the polar action of electric current prove, on the contrary, that the reactions of the undifferentiated protoplasm of the plant-body are identical with those of the animal muscle. The Laws of Polar Excitation for Plants under feeble and moderate current are :

- (1) With feeble current, the kathode excites at make and not at break. The anode excites neither at make nor at break.
- (2) With current of moderate intensity, the kathode excites at make and not at break. The anode excites at break and not at make (p. 110).

ELECTRIC RESPONSE

Two other independent methods have been devised to detect and record excitatory reaction in plants, by electromotive variation and by change of electric resistance.

Electromotive response.—All plants and their different organs respond to stimulation by an electric response of galvanometric negativity. The electric response of a motile organ persists even when it is restrained from executing any movement (p. 167). The amplitude of response, within limits, increases with the intensity of stimulation (p. 173). Uniform stimuli, applied at suitable intervals, induce uniform responses (p. 174). Fatigue is induced by shortening the period of rest, protoplasmic recovery being then incomplete (p. 175). There is an arrest of response at a minimum temperature, the amplitude of response being maximum at an optimum temperature. There is a fatal temperature at which the electric response undergoes permanent

abolition (p. 175). Strong vapour of chloroform induces rapid depression and abolition of response (p. 176).

Photic stimulation of the cell-protoplasm of a green leaf induces the catabolic D-reaction indicated by a negative electric variation, as under other modes of stimulation ; light, however, acts at the same time upon the chloroplasts, inducing anabolism in the form of photosynthesis, indicated by a positive electric variation. The negative variation, generally speaking, masks the positive, which can be detected as an after-effect upon the withdrawal of light, as also by the phenomenon of 'overshooting' (p. 182). The electric response of actively assimilating *Hydrilla* is positive, indicating the predominance of anabolism (p. 184).

Response by variation of electric resistance.—Mechanical or electric stimulation induces a diminution of the electric resistance of the tissue (p. 188). The physiological character of the response is demonstrated by the action of chloroform, which produces a rapid diminution of the amplitude of response (p. 189). The effect of the stimulus of light is demonstrated by the very sensitive Quadrant Method (p. 194). Increasing intensity of light is found to induce a corresponding diminution of resistance (p. 196). Changes of external conditions affect alike the different modes of response, by mechanical movement, by electromotive variation, and by change of electric resistance. As further examples of this may be cited the effect of feeble stimulation on a subtonic tissue, and the effect of strong stimulation on an excitable tissue. Feeble stimulation induces positive or erectile response of the leaf of *Mimosa* (p. 51), positive electromotive response of the pulvinus of the same plant (p. 166), and a positive response by increase of electric resistance of various tissues (p. 192). Strong stimulation induces multiple response in all cases (pp. 193, 238, 239). Response by mechanical movement, by electromotive change, and by variation of resistance are, therefore, different expressions of the fundamental reaction induced by external stimulation.

DEATH-SPASM IN PLANTS

An intense excitation is shown to be induced in plant-tissues at the critical moment of death.

Mechanical spasm of death.—When various plants, sensitive or ordinary, are subjected to a gradual rise of temperature, a sudden excitatory contractile spasm occurs at the critical temperature of about 60° C. (p. 202).

Electric spasm at fatal temperature.—An abrupt electromotive variation of galvanometric negativity also occurs at the critical point of 60° C. A sudden diminution of electric resistance is also found to take place at the critical death temperature (p. 210).

Death-record by apparent variation of weight.—Various organs of plants exhibit a sudden increase of apparent weight at the critical temperature, due to abrupt volumetric contraction, which is the spasm of death (p. 227).

Transmission of death-excitation.—The excitation at death is conducted to a distance, causing excitatory fall of the indicating leaves of sensitive plants (p. 212). This is equally true of excitation due to fatal temperature or to the action of poisonous solutions. The duration of application of poison for producing death-excitation is found to depend on the strength of the dose and on the virulence of the poison (p. 215).

AUTOMATIC PULSATION

Automatic movements, like those of animals, are manifested by plants, notably by the leaflets of *Desmodium gyrans*. Has this automatic movement been suddenly evolved, or is there an intermediate link between it and the ordinary responsive movement? It has been shown that this intermediate link is to be found in the multiple response under strong or long-continued stimulation, exhibited by *Biophytum* and other plants (pp. 237–242). It has also been shown that there is no strict line of demarcation between the phenomena of multiple response and of

automatic movement. Under favourable conditions for the absorption of energy from without, an ordinarily responding plant becomes converted into an automatically moving plant like *Desmodium*. Conversely, under unfavourable circumstances involving isolation from the stimuli of its normal environment, the leaflets of an automatically responding plant like *Desmodium* come to a state of standstill; it then becomes converted into an ordinarily responding plant like *Biophytum* (p. 245). Automatic or spontaneous pulsation is therefore not self-originated, but is really due to the previous absorption of energy from the stimuli of the environment.

The tonic condition is the expression of this energy-content of any tissue, and it is this that determines its physiological fitness for the normal performance of its proper function. The question naturally arises whether the energy derived from incident stimulation contributes in any degree to the performance of its normal function by the stimulated tissue. There are certain facts which can be most satisfactorily explained on the assumption that the energy derived from stimulation can be so utilised. Instances of this are seen in the revival of pulsation of *Desmodium* under electric and photic stimulation (p. 236); in the revival of the pulsation of the heart under electric stimulation (p. 259); in the renewal of the peristaltic activity of the stomach by electric, mechanical, chemical, and thermal stimulation (pp. 283-285); and in the revival or enhancement of pulsatory activity in the propulsive tissue of the sap by photic stimulation (pp. 302, 334).

CIRCULATION OF BLOOD AND CIRCULATION OF SAP

The essential identity of the rhythmic mechanism in the plant and animal is proved by the following evidence that pulsation in the plant is affected by the same agents and in the same way as pulsation in the animal.

Movements of the internal organs are well known in

animals, such as the beating of the heart and the movements of the alimentary canal. These movements are what is termed 'peristaltic,' consisting of waves of contraction travelling along the organ in the direction of propulsion. Is there anything of this kind to be found in plants?

Years ago, I published a work ('Physiology of the Ascent of Sap,' 1922) in which I demonstrated that the sap is distributed in the plant-body by the activity of certain of its living cells, which pulsate automatically after the manner of the animal heart. These cells, which exist in all parts of the body, were located in the stem by the Electric Probe, as belonging to the inner cortex (p. 329). Further investigation has thrown light upon the nature of this movement, making it clear that the movement of the sap is effected by rhythmic contraction and expansion of the cells of the propulsive tissue, constituting, as in the heart and stomach of the animal, waves of peristaltic activity.

The Law of the Propagation of Peristaltic Waves was established by experiments carried out with the animal stomach. It was shown that the peristaltic wave follows *the stimulation-gradient from the stimulated to the unstimulated region* (p. 292).

It has also been shown that the direction of movement of the sap can be determined by differential stimulation of the two ends of the organ, its flow being always from the more to the less stimulated region, whether upwards or downwards (pp. 318, 346, 357).

The results obtained with the sealed stem with its activity at standstill, are exactly parallel to those obtained with the quiescent stomach. In both, a peristaltic or an antiperistaltic wave is generated by stimulation, the direction of propagation following the stimulation-gradient from the more to the less activated region (p. 402). In both, the peristaltic wave is about four times more rapid than the antiperistaltic (pp. 289, 346). An identical law is thus illustrated by the passage of the peristaltic wave in both the animal and the plant.

The object of the experiments with sealed stems was to ascertain whether or not sap-movement could be induced in the stem without the co-operation of leaf or root and without loss or gain of water. It was so induced, consequently the results prove the existence in the plant of an independent propulsive mechanism, which works in the same peristaltic way as the heart and the stomach of the animal.

I now give a brief summary of the results upon which the assertion of the identical nature of the pulsatory mechanism in the plant and in the animal is based.

EFFECT OF EXTERNAL AGENTS ON PULSATION IN PLANT AND ANIMAL

It has been shown that pulsation in the plant, whether external or internal, is affected by the same agents and in the same way as pulsation in the animal.

Effect of variation of internal pressure.—A diminution of internal hydrostatic pressure under drought causes arrest of the pulsation of the *Desmodium* leaflet, which becomes revived under increased hydrostatic pressure after irrigation (p. 256). The pulsation of the propulsive tissue in the stem is depressed under drought and enhanced after irrigation (p. 332). In the quiescent heart the pulsation is revived by an increase of intra-cardiac pressure (p. 256). The arrested pulsation of the stomach is also revived by internal distension (p. 290).

Effect of variation of temperature.—The fact that all pulsatory activities are depressed by a fall of temperature and increased by a rise, has been demonstrated by the parallel changes induced, in the pulsation of the *Desmodium* leaflet (p. 264), in the pulsation of the heart (p. 266) and of the stomach (p. 282), and in the rate of ascent of sap (p. 303).

Necessity of oxygen for the maintenance of pulsation.—The pulsation of the *Desmodium* leaflet is arrested by

deprivation of oxygen, and specially by the asphyxiating action of CO_2 ; the arrested pulsation is revived by fresh supply of oxygen (p. 257). Similar effects are observed in the case of the pulsation of the heart (p. 258) and in that of the stomach (p. 280).

The effects of drugs are, however, the most significant evidence in proof of the identity of the physiological mechanism in the animal and in the plant.

IDENTICAL ACTION OF DRUGS ON PULSATING TISSUES IN ANIMAL AND PLANT

Stimulants, like dilute solution of Camphor, which enhance the activity of the animal heart (p. 373) also induce an enhanced activity of the propulsive tissue in the plant, exhibited by a sudden increase of sap-pressure in which the individual pulsation shows an up-stroke larger than the down-stroke (p. 374).

Morphine causes a depression of the heart-beat (p. 378); its action on the pulsation of the plant is a diminution of pressure, the down-stroke of each individual pulsation being larger than the up-stroke (p. 375).

The same antagonistic action of different drugs is exhibited in both plant and animal. Muscarin and Pilocarpin cause arrest of the heart, whereas Atropin, by its physiological antagonism, revives the activity. Effects exactly parallel are induced in the pulsating leaflet of *Desmodium* (p. 270).

The characteristic effects of various drugs on plant and animal are so very similar that the physiological action of extracts of various plants on the activity of the animal heart has been discovered by their action on the pulsating tissue of the plant (p. 270).

These results offer further convincing proof that the mechanism for the propulsion of the sap in the plant is physiologically similar to that for the circulation of the blood in the animal.

CONCLUSION

To sum up all the accumulated experimental evidence adduced in the pages of this book, it has first of all been demonstrated that the familiar and striking movements of 'sensitive' plants are accompanied by all the physiological signs—such as electromotive variation, behaviour under change of external conditions and under the action of anæsthetics and other drugs, reaction to stimulation—which are characteristic of the contraction of animal muscle. It must therefore be concluded that the motile organs of these plants include a tissue which closely resembles animal muscle in its properties.

It has also been shown that ordinary, non-sensitive, plants respond to stimulation by movement which is not always perceptible, but can be detected by sensitive apparatus with high magnification. Their response has been shown to be accompanied by all the physiological signs which are characteristic of that of sensitive plants. Moto-excitability is therefore not limited to certain plants, but is possessed by them all.

It has been further demonstrated that just as in the animal body there is a rhythmic peristaltic movement of internal organs concerned with the circulation of the blood and with the propulsion of food along the alimentary canal, so also in the plant-body there is a similar peristaltic movement in a tissue distributed throughout it, which constitutes the organ for the propulsion of the sap. All the experimental conditions which affect the movement of the heart or the stomach of the animal have been proved to affect in just the same way the activity of the tissue effecting the propulsion of the sap in the plant. Here again similarity of behaviour justifies the assertion of physiological identity. Nor is this identity surprising; for there is a common factor in the motor mechanism of plant and animal, the moto-excitability of the protoplasm of which they both consist.

The gradual evolution of the motor mechanism has been traced, through intermediate types, from the simplest to the most complex. The study of the life of the plant thus assumes its true importance and significance, not only from the evolutionary point of view, but also from the prospect it holds out of pointing the way to the solution of many of the perplexing problems in the life of the animal. The life-movements of plants must therefore be regarded as an integral part of the study of the general physiology of living organisms, without which that study will be but partial and incomplete.

INDEX

- A- AND D-REACTIONS, 50, 51, 54, 145, 182-5, 407
- Abroma augusta*, effect of, on *Desmodium* pulsation, 271, 272 ; on pulsation of heart, 271, 272
- Accession and depletion of energy under stimulation, 48, 54, 234, 407
- Acid and alkali, antagonistic action of, on mechanical response, 87-8, 408
- Active and inactive pulvinus and muscle, 64, 65
- 'Active substance,' micro-chemical reactions of, 61-5, 66 ; rapidity of contraction dependent upon, 60, 63, 65, 66, 67, 140, 141, 407
- Additive effect of stimulation : on electric response, 170 ; on mechanical response, 45, 408
- Age, effect of, on moto-excitability, 81, 83 ; on response to photic stimulation, 178
- Ammonia, effect of, on moto-excitability, 76 ; on rhythmic movement, 273, 285
- Anabolism and catabolism, 55
- Anaesthetics, effect of, on moto-excitability, 75, 176, 408
- „ death-spasm under, 76 ; similar action of, on plant and animal, 77, 408
- Anatomy of pulvinus of *Mimosa*, 60
- Anisotropic organs, continuity of response in radial and, 150, 153, 405
- Anisotropy, induction of, by gravitational stimulus, 153, 406
- Antagonistic action of drugs on animal heart, 269, 270, 375, 380, 415 ; parallel action on propulsion of sap in plants, 375, 380, 415 ; on *Desmodium* pulsation, 270, 415
- Antiperistaltic and peristaltic waves, relative intensity of, in heart and stomach of animal, 287-92 ; in stem of plant, 315-35, 344, 389, 402, 413
- Ascent of sap, theories of, 293 *et seq.*, 320, 337, 381, 384, 399, 401
- „ „ effect of poison on, 295 *et seq.*, 305
- „ „ „ stimulant on, 295, 296, 297, 304
- „ „ „ tonic condition on, 300
- „ „ „ variation of temperature on, 301, 303-4, 414
- „ „ „ light on, 302
- „ „ „ electric stimulation on, 302-3
- „ „ independent of root-pressure and transpiration, 318, 319, 337, 339, 340, 343, 346-7, 357, 399
- „ „ unidirectional flow, 337, 343, 347
- „ „ rôle of transpiration in, 343 ; rate of, in intact and in isolated stem, 353
- „ „ normal ascent due to differential stimulation, 400 .
See also under Sap-movement

- Assimilation and dissimilation, theory of, 54
- Atropin, action of, 273, 380; on *Desmodium* pulsation, 270, 415; on heart-beat, 269, 270, 375, 415; on propulsive pulsation in plant, 376
- Automatic movements not self-originated, 247, 412
- Automatic pulsation, 229 *et seq.*; in *Desmodium*, 232, 411; due to previous storage of energy, 233, 237, 245, 412; revival of, under external stimulation, 235-7, 414; causal relation of quantity of stimulation and persistence of revived pulsation, 235-7, 259; continuity with multiple response, 245, 411; characteristics of, 254; similarity of in plant and animal, 255-73, 412; effect of feeble and strong stimulation on, 259-62. *See also under* Rhythmic activity
- Automatic recorder, for diurnal variation of excitability, 91, 92
- Automaticity, different grades of, in sinus, auricle and ventricle of heart, 252
- Averrhoa, polar action of current on, 108, 110; transmission of death-excitation in, 214
- BARIUM chloride, effect of, on contractile response, 87, 408
- Basella, death-spasm of stem of, 208; death-record by variation of weight, 223
- Bayliss, cited, 55; quoted, 66
- Biedermann, cited, 114
- Biophytum sensitivum*, 75; single mechanical response of, 25, 238; multiple mechanical response under strong stimulation, 238, 239, 411; multiple electric response of, 239; multiple response under direct photic stimulation, 240; polar action of current on, 109; transmission of death-excitation in, 216
- Block, method of, in torsional stimulation, 169
- Bubble-method for investigating the directive movement of sap, 355
- CAFFEIN, action of, on pulvinar response, 125; on pulsation, 379
- Calotropis gigantea*, response of, by variation of electric resistance, 188
- Camphor, action of, on pulvinar response, 123, 408; on muscular response, 124, 408; on heart-beat of animal, 373, 415; on propulsive pulsation in plant, 304, 374, 379, 390, 392, 415
- Carbon dioxide, asphyxiating action of, 272; on mechanical response of *Mimosa*, 73, 122; on *Desmodium* pulsation, 257, 280, 415; on cardiac pulsation, 258, 280, 415; on peristaltic pulsation of stomach, 281, 415
- Carbon disulphide, effect of, on contractile response, 76
- Cardiac activity, study of induced variation of, 251-2; myogenic and neurogenic theories of, 252; characteristic features of, 254, 414; effect of thermal stimulation on, 265; effect of drugs on, 267, 415
- Cardiogram, characteristics of, in different animals, 249-251
- Cardiograph, Resonant, 248
- Carissa Carandas*, death-record of, by apparent variation in weight, 221, 226
- Cell-Sphygmograph, automatic, 133
- Cellular contraction and expansion under drought and irrigation, 156, 162
- Cellular contraction under stimulation, 134 *et seq.*, 160, 161; measurement of, in *Mimosa* pulvinus, 129 *et seq.*

- Cellular contraction in stem of *Mimosa*, 138-40
 „ „ in ordinary stem, 142-3
 „ „ in stem, leaf-joint and pulvinus, 159, 160, 162
 „ „ universality of, 145, 405
- Cellular mechanism : continuity of, in the plant, 142, 162 ; for propulsion of sap, 315, 316, 328-9, 401
- Cellular pulsation, 359, 413 ; discovery of, 364 ; electromotive variation of, 329 ; effect of stimulus on, 332 ; effect of variation of temperature on, 333, 367 ; arrest of, under diminished internal pressure, 332 ; in unidirectional propulsion of sap, 335 ; arrest under ligature, 368-70, 371 ; and revival under stimulation, 368, 369, 371
- Cellular pump, valve action in, 346
- Chloroform, effect of, 408 ; on mechanical response of *Mimosa*, 76 ; on pulvinar response, 122 ; on electromotive response, 176, 410 ; on response by variation of electric resistance, 189
- Clockwork Oscillator, 23
- Cobra-venom, action of, 377, 379, 380
- Cold, effect of, on ascent of sap, 303, 351, 382, 393 ; on moto-excitability, 94
- Conduction of excitation, 13 ; in flower stalk of *Biophytum*, 216
- Conductivity, independent of moto-excitability, 80, 81
- Contractile cells, continuity of, between stem and leaf, 140, 141, 317, 324
 „ granular character of protoplasm in active, 64, 67
 „ response, similarity of, in plant and animal, 68, 406
 „ tissue, demarcation of, in pulvinus, by differential staining, 61 *et seq.*, 407
- Contraction, diametric, under stimulation : in *Mimosa* pulvinus, 136-8, 141, 404 ; in stem of *Mimosa*, 138-40, 141, 404
- Critical minimum temperature for moto-excitability of *Mimosa*, 73 ; for *Desmodium* pulsation, 263 ; for pulsation of heart, 265 ; for pulsation of stomach, 282
- DEATH, symptoms of, in plants, 200 ; record of, thermo-mechanical, 201 ; electric, 209 ; variation in weight, 219
- Death-excitation, transmission of, 212 *et seq.*, 411 ; under scalding, 213-5, 411 ; under action of poison, 215, 216, 218, 411
- Death-point, determination of, in plants, 200 ; lowering of fatal temperature under fatigue or injury, 204, 210, 212, 222 ; constancy of, in different organs, 210
- Death-record : by abrupt variation of apparent weight, 219, 227, 228, 411 ; of fruit, 221, 223, 226 ; of stem, 223 ; of petiole, 224 ; of root, 225 ; of living tissue balanced by dead tissue, 225, 226, 228 ; underlying cause, 225, 227
- Death-spasm, electric, 197, 209, 211, 219, 409, 411 ; under anaesthetic, 76 ; at fatal temperature, 197, 201-3, 204, 411 ; thermo-mechanical record after, 203 ; thermo-mechanical curve of, 222, 227, 228 ; in *Mimosa*, 201, 210, 212, 222 ; in ordinary pulvinus, 206 ; in pulvinoid, 206 ; in geotropically curved stem, 208 ; in radial organs, 208, 210
- Desmodium gyrans*, 229 ; record of pulsation of, 229 *et seq.* ; automatic pulsation of, 247

- Desmodium pulsation, dependence of, on storage of energy, 234, 246; effect of electric stimulus on arrested pulsation, 236, 246; effect of light on, 236; record of pulsation of isolated pulvinus, 253; effect of drought and irrigation on, 255, 256, 414; asphyxiating action of carbon dioxide on, 257, 280; effect of oxygen on, 256, 257, 280; effect of variation of temperature on, 262 *et seq.*, 414; critical temperature for arrest of, 263; effect of spirit. ammon. aromatic. on, 267, 268; effect of extract of *Abroma augusta* on, 271, 272; effect of small and large dose of potassium bromide on, 268; antagonistic action of Pilocarpin and Atropin on, 270
- Diametric contraction, method of, 130 *et seq.* See under Cellular contraction
- Differential excitability, determination of, in pulvinus of Mimosa, 148; in leaf-joint, 149; in petiole, 149
- Differential stimulation, effect of, on direction of peristaltic wave in stomach, 292; on direction of propulsion of sap in plant, 357
- Dose, opposite effect of small and large, on response, 74, 76, 376, 378, 379, 408
- Drugs, similar effects of, on pulsating tissues in animal and plant, 372, 379, 408, 415; physiological antagonism of, 269, 270, 273, 375, 380, 415; camphor, stimulating action of, 373, 374, 379, 408; morphine, depressant action of, 374, 375, 378, 379, 415; antagonistic action of bromide and musk, 375, 376, 377; opposite effects of small and large dose of strychnine, 376, 378, 379, 380, 408; action of cobra-venom, 377, 379, 380
- ELECTRIC current, excitation by polar action of, 106
- ,, Probe, localisation of pulsating layer by, 295, 327, 328, 335, 413
- ,, pulsation in Desmodium leaflet, 325-7; in cortex, 330 *et seq.*
- ,, response by variation of resistance, 186 *et seq.*, 409, 410; effect of chloroform, 189, 410; effect of sub-minimal stimulus, 193; multiple response under strong stimulation, 193; death-response at fatal temperature, 197, 209, 219, 409, 411. See also under Quadrant Method
- ,, stimulation, effect of, on Desmodium pulsation, 236, 260 *et seq.*; on pulsation of heart, 259; on pulsation of stomach, 283; on propulsion of sap, 302
- Electro-magnetic Phytograph, 18
- Electromotive response, 163; method of Block, 169; effect of torsional stimulation on, 169 *et seq.*; of anaesthetic on, 176, 410; of fatigue on, 174, 409; of temperature on, 175; of tonic condition on, 167; of poison on, 177; Photo-electric cell for investigating response to light, 180; normal response to light, 179, 181, 185, 410; positive after-effect, 182, 185, 410; positive response of Hydrilla, 184, 185, 410
- Electro-oscillating Recorder, 21
- Electro-thermic stimulation, 11
- Energy, accession and depletion of, in response, 48, 54, 234; dissipation of, in response, 48
- Engelmann, 114, 252
- Erectile response, method of, 294, 300

- Erythrina indica*: mechanical response of, 26; effect of stains on pulvinus of, 63, 64
- Ether, effect of, on moto-excitability of Mimosa, 75, 408
- Eucharis Lily, sensitiveness to cold, 175
- Excitability, determination of scale of, by differential staining, 63, 67; effect of age on, 83; rate of decay of, after section, 83-5; effect of external variations on, 93 *et seq.*, 98; diurnal variation of, 90, 96-9, 102, 105; seasonal variation of, 102
- Excitatory reactions of different plant-organs, 205
- Expulsion of sap from stimulated cells, 8
- FATIGUE, effect of, on mechanical response, 47, 53; on electric response, 174; on electric resistance, 193; lowering of death-point by, 204
- Fatigue-relaxation, 48, 408
- Fatigue-reversal under continuous stimulation, 47
- Flowers, death-movement of, 207
- Friction, error in record due to, 14, 16, 19, 27, 248, 249, 250
- GALVANOMETRIC, negativity, concomitance of, with excitatory contraction, 163, 177, 325, 331, 409; positivity with expansion, 166, 325, 331
- Gaskell, 54, 252
- Geotropism, induction of anisotropy by, 153, 406
- Glycerine, effect of, on water-logged tissue, 71
- Gourds, death-record of stem of, 224
- HABERLANDT, on light-perception of plants, 10; on expansive reaction of upper half of Mimosa pulvinus, 28
- Hæmatoxylin and Bismarck Brown, staining reaction with, 62
- Heart, automatic pulsation of, 229, 243; effect of external agents on, 414; peristaltic wave in, 275, 286; rhythmic mechanism of, 248. *See also under* Cardiac activity
- Heat, effect of, on moto-excitability, 72; on propulsion of sap, 383, 384, 393, 399
- Helianthus (Sunflower), response of, by variation of resistance, 191-3; residual current in bare stem, 349; responsive variation under differential stimulation, 350 *et seq.*; rate of ascent of sap in, 354
- Hering, assimilation and dissimilation, 54
- Hibiscus, death-response at fatal temperature, 197; movement of sap in, 355, 356
- Hormones, 401
- Hydrilla, positive electric response of, under light, 184, 185, 410
- INDIAN plants, physiological action of extracts from, 270-2, 273, 415
- Induction-shock, calibration of intensity of, 12-13; stimulation by, 11
- Inertia, physiological, effect of, on response, 101
- Interaction and intercommunication in plant, 401, 402
- Iodine-Green and Alum-Carmine, staining reaction with, 62
- Ipomoea pulchella*, response of, by variation of electric resistance, 191
- KNOLL, animal muscle, 65

- LATENT period, determination of, in pulvinus of *Mimosa*, 44, 68, 145; in ordinary cortex, 145
- Law of Propagation of Peristaltic Wave, 292, 402
- Laws of Polar Action of current on plants, 110, 117, 409; supplementary laws, 114, 117
- Leaf-joint, anisotropy and differential excitability in, 149
- Leaf-movement, action of poison on, 297; its relation to the propulsion of sap, 298
- Leafless trees, movement of sap in, 393
- Ligature, of the heart, 259, 368; of the stem, 368
- Light, A- and D-reactions under, 50, 178, 182
- ,, effect of, on moto-excitability, 69, 86, 93, 96
- ,, ,, ,, response of *Mimosa*, 69, 86, 93
- ,, ,, ,, pulsating response of *Desmodium*, 236
- ,, ,, ,, ascent of sap, 302
- ,, electromotive response to stimulus of, 179, 181, 185, 410
- ,, 'overshooting' after stimulation by, 181, 182, 183, 184
- ,, positive 'after-effect' of, 182, 185, 410
- ,, stimulating action of, 86; on electric pulsation of propulsive tissue, 333-4
- Lupin, 301, 343, 347
- MERCURIC chloride, action on plant, 216
- Methylene Blue and Erythrosin, staining reactions with, 61
- Mimosa pudica*, 6, 78; mechanical response of, 24; contractility of upper half of pulvinus, 28; unequal pliability of pulvinus, 30; response of, in inverted position, 33, 407; effect of weight of leaf on response, 34; comparison of excitability of two halves of pulvinus, 37; characteristic difference of response of highly excitable and subtonic pulvinus, 39; dependence of amplitude of response on number of excited cells, 40, 408; rate of mechanical recovery dependent upon ascent of sap, 41; rate of work performed by falling leaf, 41; latent period of response of, 44; additive effect of stimulation on response, 45; uniform responses of, 46; fatigue-relaxation of, 47; erectile response of subtonic specimens, 50, 410; transformation of response from positive to negative, 50; rapidity of contraction, dependence of, on presence of active substance, 60, 138, 407; demarcation of active and inactive pulvinar cells by staining, 61, 407; effect on moto-excitability, of variation of light, 69, 86; of excessive turgor, 70-2, 94, 168; of variation of turgor, 99; of change of temperature, 72, 94, 95, 96; of ozone, 73; of carbon dioxide, 73, 122; of sulphuretted hydrogen, 74; of ether, 75; of chloroform, 76, 122; of barium chloride, 87; of acid and alkali, 87, 88; of camphor, 123; of caffeine, 125; of musk, 125; of strychnine, 120; inhibition of response by excessive absorption of water, 70, 168; diurnal variation of excitability of, 90, 407; petiole-pulvinus preparation of, 78-80, 85, 88, 406; isolated pulvinar preparation of, 118; electro-motive response of fixed leaf, 167; diametric contraction in pulvinus and cortex, 137, 404-5; death-spasm of, by scalding, 201; by poison, 215
- Mimosa Spegazzinii*, excitability of, 62
- Morphine, depressant action of, 374, 375, 378, 379, 415

- Moto-excitability, 2, 80 ; diurnal variation of, 90, 407 ; of all plants, 404
- Multiple response, of all tissues, 239 ; under strong stimulation, 193 ; electrical, 193, 239 ; mechanical, 238 ; under transmitted death-excitation, 217 ; link between ordinary response and automatic movement, 238, 245, 246, 411
- Musa sapientum*, electromotive response of leaf to light, 182, 183, 184
- Muscarin, action of, 269, 270, 273, 415
- Muscle, active and inactive, 65
- Musk, effect of, 379 ; on pulvinar response of *Mimosa*, 125 ; effect of, on pulsation of heart, 375, 376 ; on propulsive pulsation in plant, 374, 377
- Myogenic and neurogenic theories of origin of activity of heart-beat, 252
- NEPTUNIA, mechanical response of, 25 ; polar action of current on, 110 ; staining reaction of pulvinus of, 64, 407
- Neurogenic and myogenic theories of origin of activity of heart-beat, 252
- Nitrogen dioxide, action of, on moto-excitability, 76
- OPTICAL lever, 15, 27
 ,, Sphygmograph, 144, 359
- Ordinary plants, diametric contraction of stem of, 145, 405 ; electric response of, 168 ; motor response of stem of, 142 ; polar excitation of, 116 ; response of leaf of, 146, 157 ; response of petiole of, 149 ; response in general, 404, 405 ; unilateral stimulation by bending of, 151
- Oscillating Recorder, Electro-, the, 21
- Oscillator, Clockwork, the, 23
- ' Overshooting,' phenomenon of, in response, 181, 183, 410
- Oxygen, necessity of, for maintenance of pulsation of *Desmodium*, 256, 257, 272, 280, 415 ; of animal heart, 257, 258, 272, 280, 415 ; of peristaltic pulsation of stomach, 280, 281, 415
- Ozone, stimulating action of, on *Mimosa*, 73
- PERISTALTIC pulsation of stomach, characteristics of, 278 ; effect of asphyxiation by carbon dioxide on, 281 ; revival by oxygen, 281 ; effect of variation of temperature on, 279, 281 ; revival of, under electric stimulation, 283-5 ; under chemical stimulation, 285-6, 290, 291 ; under mechanical stimulation, 289, 290 ; under thermal stimulation, 291
 ,, and antiperistaltic waves, 413 ; in heart, 286, 287 ; in stomach, 286, 287, 386, 389, 402 ; in stem, 318, 344-6, 389 *et seq.*, 401, 402 ; relative intensity of, 287-9, 317, 319, 344, 346, 388, 390, 395
 ,, wave, law of propagation of, 292 ; in plant, 357
- Peristaltograph, 276
- Petiole, anisotropy and differential excitability of, 149
- Petiole-pulvinus preparation of *Mimosa pudica*, 78
- Pfeffer, on pulvinus of *Mimosa*, 35
- Pfluger's Law, 114
- Phaseolus, mechanical response of, 26 ; effect of stains on, 62, 64, 407
- Photo-electric cell for plant-response to light, 180, 185
- Photo-synthesis, 86, 184, 185, 410

- Physiological antagonism of drugs, 269, 270, 375, 415
 ,, inertia, effect of, on response, 95, 101
 ,, mechanism, similarity of, in plant and animal, 68, 416
- Phytogram, the, 14, 27, 324
 ,, and sphygmogram, simultaneous, 315
- Phytophograph, Electro-magnetic, 18
- Pilocarpin, action of, on *Desmodium* pulsation, 270, 415; on heart-beat, 269, 270, 273, 415
- Plant-Sphygmograph, 310-12, 323
- Plasmolysis, 156, 157, 158, 160, 162, 406
- Poison, effect of, on ascent of sap, 297, 298, 305, 306, 307, 396; on leaf movement, 297; on sap-pressure, 363; theories of Strasburger, 293, 295; death-excitation by action of, 215, 216, 411
- Polar action of current, excitation by, 106 *et seq.*, 409; demonstration of, by Bipolar method, 109 *et seq.*, 147; by Monopolar method, 107; on ordinary plants, 116
- Polar excitation in plants, laws of, 110, 117, 409; supplementary laws of, 114, 117
- Porana paniculata*, response of, by variation of electric resistance, 191
- Post-mortem relaxation, 204, 223
- Potassium bromide, depressant effect of, 271, 272, 273, 304, 306, 375, 379; opposite action of large and small dose: on *Desmodium* pulsation, 268; on heart-beat, 269, 375
 ,, chloride, effect of, on cellular contraction, 40
 ,, cyanide, action on plant, 216
- Potograph, determination of movement of sap by, 337-8; detection of directive movement under differential stimulation by, 349 *et seq.*
- Propulsive tissue, localisation of, by Electric Probe, 295, 327, 328, 335, 413; electric record of pulsation in, 330
- Protoplasmic reaction, identical character of, under diverse modes of stimulation, 10; to external stimulation, 54
- Protozoa, polar action of electric current on, 106
- Pulsation, automatic, 229, 411; effect of external agents on, in plant and animal, 414; cellular, electric record of, 325; mechanical record of, 358, 364
- Pulvinar response, 120; effect of caffeine on, 125; of camphor on, 123; of chloroform on, 122; of carbon dioxide on, 122; of musk on, 125; of strychnine on, 126
- Pulvini, active, semi-active and inactive, 26, 58, 64; rates of contractile reaction in, 59; characteristic staining reactions of, 64
- Pulvinule, isolated, of *Desmodium*, pulsation of, 253, 254, 256
- Pulvinus of *Mimosa*, anatomy of, 60; response of isolated, 118
- QUADRANT method of detecting response by variation of resistance, 194, 198, 410; effect, of photic stimulation, 195; of a single spark, 196; of increasing intensity of light, 196
- RADIAL organs, induction of physiological anisotropy in, 153-5, 406; longitudinal contraction of, 150, 405; response of, by bending under unilateral stimulation, 151-3; tropic curvature of, 153, 405
- Reactions, positive and negative, 51, 197, 407

- Recording Balance, determination of death-point by, 219
- Refractory period in pulsation of *Desmodium* and of animal heart, 243, 244
- Relaxation, post-mortem, 204, 223
- Resistance-variation under stimulation, 186, 410; mechanical stimulation, 186; electric stimulation, 189; effect of chloroform on, 189, 197; effect of sub-minimal stimulus, 193; multiple response by, under strong stimulation, 193; photic stimulation, 194; response by, at critical fatal temperature, 197, 209, 211
- Resonant Cardiograph, 248, 372
 ,, Recorder, 19
- Response, devices for record of, 13; by electromotive variation, 163, 178, 409; by variation of electric resistance, 186, 410; motor, of *Mimosa*, 44, 406; motor, of ordinary plants, 142; of radial and anisotropic organs, 150, 405; positive and negative, 56
- Rhythmic activity, theories of, 252
 ,, ,, characteristics of, 254
 ,, ,, effect of variation of internal pressure or distension on heart-beat, 256; on *Desmodium* pulsation, 256; on pulsation of stomach, 289; effect of variation of temperature on pulsation of heart, 265-7, 281; on pulsation of *Desmodium* leaflet, 262-265, 266, 281; on pulsation of stomach, 278-9, 281; on rate of ascent of sap, 303-4. *See also under* Automatic pulsation
 ,, mechanism in plant and animal, 248, 415
- Rhythmicity, cause of, 244
- SAFRANIN, staining reaction with, 61
- Sap-movement, activity exists throughout the length of the plant, 306; effect of physiological changes on, 306, 363, 371; effect of subtonicity on, 49, 306; effect of external stimulation on, 306; propulsive mechanism of, 49, 307, 328-9; detection of, in the stem, 308; identical in stem and leaf, 316; movement in up and down direction, 318, 324; a peristaltic action, 318, 342, 347, 348, 413; rate of flow, 339, 342; in stem without root or leaf, 340; under differential stimulation, 348, 413; in bare stem under thermal stimulation, 350, 357; determination of directional movement by Bubble-method, 355 *et seq.*; law of directive movement, 357, 397, 399; responsive in sealed stems, 381, 413. *See also* Ascent of sap
- Sap-pressure, record of variation of, in the stem, 308-9; periodic variation of, 320; diurnal variation of, 321; in leafy and in leafless trees, 320, 321, 323, 324; induced variation in shoot, 365
- Schafer, cited, 5
- Schwendener, on pulvinus of *Mimosa*, 32
- Secondary poles, 114
- Semi-automatism, 245
- Sensitivity, comparison of, between human subject and plant, 12, 144
- Sinus, importance of, in cardiac pulsation, 252, 265, 286
- 'Sleep' of plants, 90
- Sphygmograph, automatic, method of, 133; high magnification, 309, 311; optical, 144, 359, 360, 362; magnetic, 364, 371, 372

- Spiritus Ammoniae Aromaticus, effect of, on cardiac pulsation, 267;
on Desmodium pulsation, 267, 268; on pulsation of stomach, 285,
286
- Staining, double, differentiation of contractile tissue by, 61
- Staircase response, 52, 53, 84, 89, 102, 408
- Stannius, ligature of the heart, 259, 368
- Starling, quoted, 276
- Stimulation, identical reaction under different modes of, 10; methods
of, 9; quantitative, by thermo-electric shock and induction-shock, 10;
A- and D-effects of, 50, 51, 54, 145, 182-5, 407; additive effects, 45,
170, 408; by torsional vibration, 169; positive and negative reactions
under, 197; initiation of pulsation in quiescent stomach under chemi-
cal, 285-6; under electric, 283-5, 288; under mechanical, 287
- Stomach, peristaltic movement of, 276; effect of carbon dioxide on, 281;
under stimulation, 287, 414
- Strasburger, on movement of sap, 293
- Strychnine, action of, on pulvinar response, 126; on muscular response,
127; on heart-beat of frog, 376, 378; on propulsive pulsation of
plant, 376, 379; opposite effects of large and small dose, 370, 378,
379, 380, 408
- Subtonic condition, 49, 333, 407
.. tissue, electric response of, 167; mechanical response of, 50;
positive response of, 50, 167
- Sulphuretted hydrogen, abolition of moto-excitability by, 75
- Sunflower, effect of differential stimulation on directive movement of sap
in, 349
- Systolic and diastolic movement of Desmodium leaflet, time-records of, 232
- TAPPING RECORDER, 16
- Temperature, effect of variation of, on movement of Mimosa, 72; on sap-
movement, 301, 303, 313; on Desmodium pulsation, 262; on ex-
citability, 93 *et seq.*; on heart-beat, 265; on moto-excitability, 93,
96, 100-1; on pulsation of stomach, 281; on rapidity and amplitude
of contraction (Mimosa), 72
- Tetanisation, after-effect of, 87; exciting value of, 91
- Thermal stimulation, 9; of bare stem, causing responsive variation in
sap-movement, 350
- Thermo-mechanical curve, inversion of, at critical point of death, 201;
record after death, 203
- Tonic condition in general, 4, 49; modifying influence of, on response, 51,
54, 145, 234, 235, 259, 283, 333, 407
- Torsional stimulation, method of, for electromotive response, 169
.. Stimulator, 170
- Transpiration-current, effect of variation of, on propulsive activity, 314;
rôle of, in ascent of sap, 343
- 'Trigger' action, 48, 57, 407
- Tropaeolum, leaf of, response to photic stimulation by variation of electric
resistance, 194
- Turgor, 4, 306; balanced, 310, 349, 364, 367; effect of variation of, on
contractile response, 99; relation to electric response, 329; to
mechanical response, 330

URETER of rabbit, Engelmann and Biedermann's experiments on, 114

WATER HYACINTH (*Eichhornia*), pulvinoid of, death-point of, 206

Water-logged condition, effect of, on muscular response, 70, 408; on pulvinar response, 8, 70, 80, 94, 168, 408; of pulvinus, persistence of electromotive response in, 168

Weight, apparent variation in, at death, 221

Wound, effect of, on excitability, 80, 83, 84, 85, 89, 121

XYLEM-VESSELS, 8, 328

*Printed in England at THE BALLANTYNE PRESS
SPOTTISWOODE, BALLANTYNE & CO. LTD.
Colchester, London & Eton.*







